

## Data sheet

# Automatic balancing valves

## ASV-PV DN 50 -100 (3rd gen.)

## Description / Application

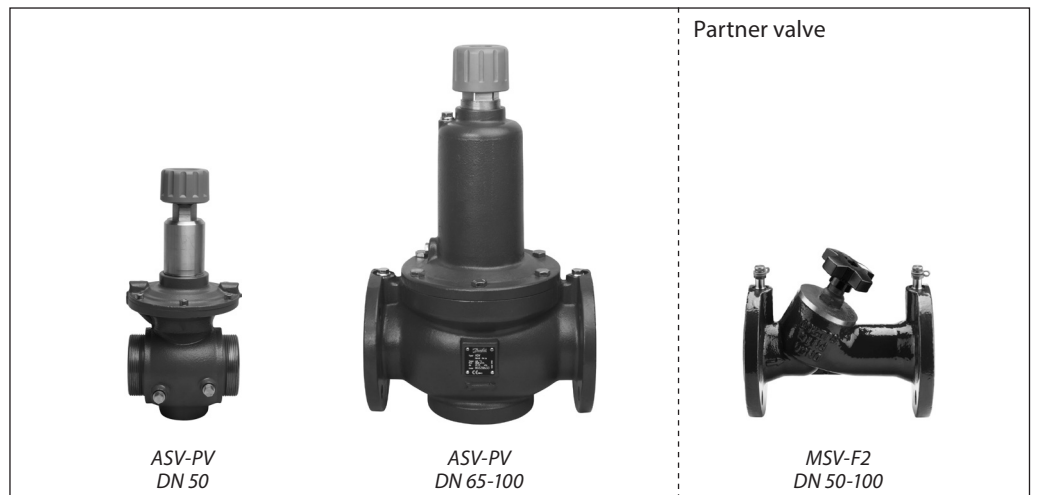

ASV balancing valves are used for dynamic hydronic balance in heating and cooling systems. One of the major challenges in heating and cooling systems is a lack of good hydronic balancing, caused by differential pressure, which is changing constantly and unpredictably in the system. This often results in complaints about poor indoor comfort, noise and high energy bills.

ASV automatic balancing valves ensure an optimal pressure differential for control valves as well as the correct flow within the individual risers at all times. The ASV automatically creates an optimal hydronic balance within the installation, whether under full or partial load. This balance is never disrupted.

#### Flow limitation

By using combination of pressure controller ASV and settable terminal's unit valve, flow limitation is established.

Flow limitation for each terminal unit prevents underflows on distant units and overflows on others thus allows efficient pumping.

#### Lower noise emission

Differential pressure limitation provides the pressure over the control valve not to increase at partial loads thus noise emission will be lower. (This is the reason why DIN 18380 requires control of differential pressure by partial load.)

#### No balancing method needed

Flow limitation is achieved by adjusting each hydronic loop separately without influencing others, which consequently results in one time adjusting process. No special balancing method is needed so commissioning cost can be saved.

#### Control valve authority

Controlling differential pressure over the control valve means that authority is high – which allows an accurate and stable control as well as energy saving.

#### Zone balancing

By installing the ASV sets you can divide the piping system in pressure independent zones. This allows a gradual connection of zones to the main in new constructions or at renovation without using an additional balancing method. There is no need to perform a new commissioning every time the system is changed because the hydronic balance is done automatically.

ASV-PV valves are settable in different ranges:

- 5-25 kPa setting is mostly used for radiator application,
- 20-40 kPa setting is used for fan coil, chilled beam and flat station applications,
- 35-75 kPa setting is used for flat station and fan coil, chilled beam application,
- 60-100 kPa setting is used for large terminal unit application (air handling units, fan coils, etc.).

Using ASV valves it is possible to optimize pump head while independent pressure zones allow to keep authority of terminal unit's valve high.

ASV balancing valves are designed to guarantee high quality of the automatic balancing by:

- a pressure released cone,
- an adapted membrane for every valve dimension which provide constant quality performance for all sizes,
- spring with linear characteristic that makes setting required  $\Delta p$  easy.

**Description / Application**  
(continuous)

ASV valves DN 50 is supplied with external thread only. Threaded or weld tail pieces can be supplied as an accessory. Dimensions DN 65-100 are supplied as flanged valves.

ASV balancing valves have integrated service functions such as shut-off.

ASV-PV can be equipped with plug for flow measuring. In that case measuring plugs need to be ordered separately and

mounted on the valve as follows:

- on top of drain connection (DN 50),
- on the flange connection before the valve is filled with water (DN 65-100).

ASV-PV valves are to be mounted in return pipe, in combination with partner valves mounted in flow pipe. As a partner valve MSV-F2 is recommended.

There are two basic configurations when using ASV partner valves (MSV-F2):

- partner valve outside the control loop (Fig. 1). Recommended configuration: it results in best performance since whole controlled pressure range is available to the riser. Flow limitation is done on each terminal unit in the riser.

- partner valve inside control loop (Fig. 2). Offers flow limitation on the riser however part of the controlled pressure range is used by pressure drop on partner valve ( $\Delta p_i$ ). It is recommended when flow limitation on each terminal unit is not possible.

MSV-F2, by connecting impulse tube to down-flow test plug.

MSV-F2, by connecting impulse tube to up-flow test plug.

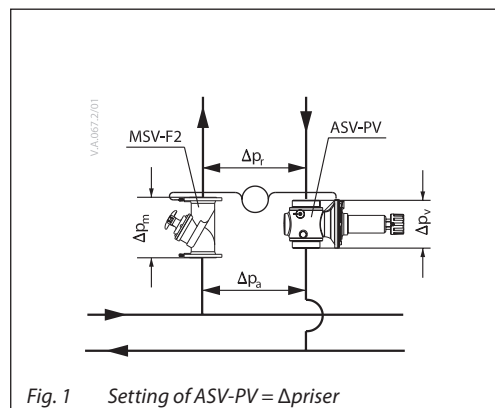

Fig. 1 Setting of ASV-PV =  $\Delta p_{riser}$

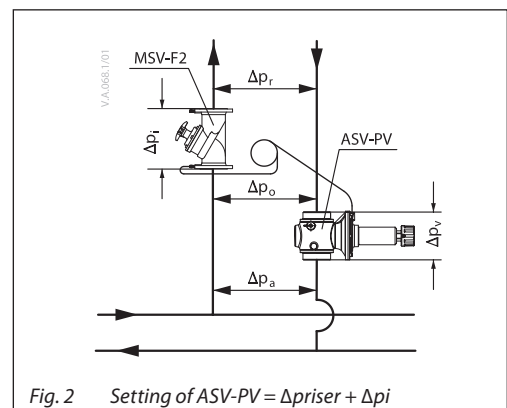

Fig. 2 Setting of ASV-PV =  $\Delta p_{riser} + \Delta p_i$

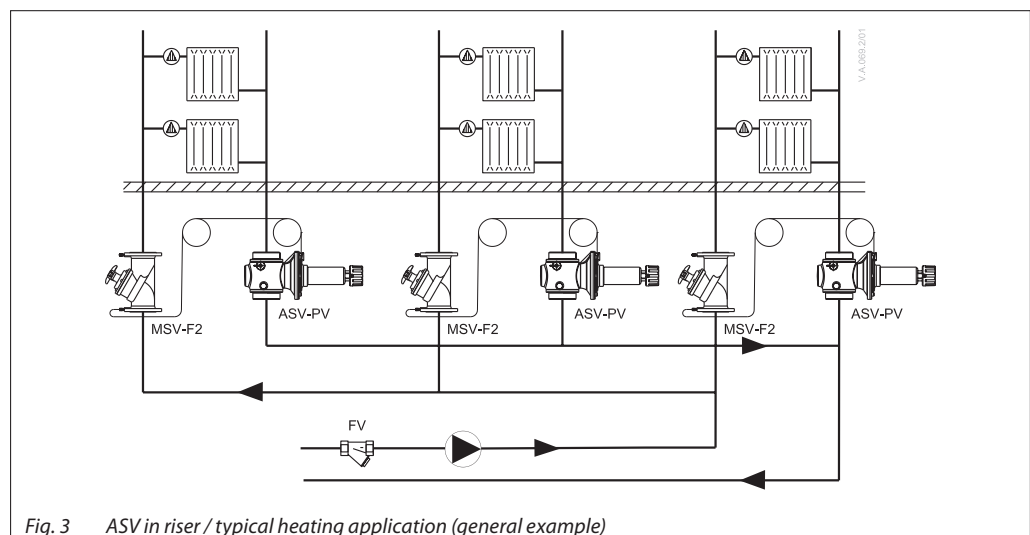

Fig. 3 ASV in riser / typical heating application (general example)

ASV valves are to be used in heating systems to control the differential pressure in risers. To limit the flow for every radiator, the thermostatic radiator valve with pre-setting facilities (feature) is used together with a constant pressure provided by the ASV, thus providing balanced heat distribution.

Controlling differential pressure over the riser means also that the valve authority over the thermostatic radiator valves is high – which allows an accurate and stable temperature control and saves energy.

Description / Application  
(continuous)

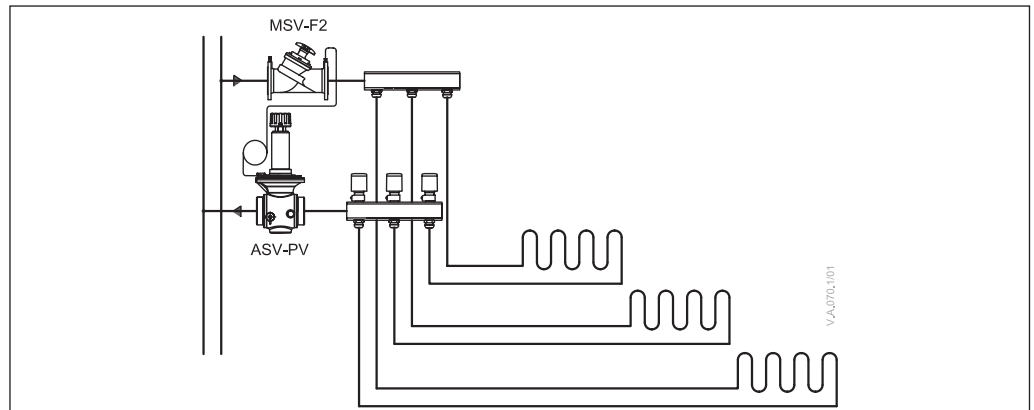

Fig. 4 ASV in manifold for floor heating system

ASV valves are to be used in floor heating systems. To limit the flow for every loop valves with an integrated flow limiting or presetting function should be used together with a constant pressure provided by an ASV-PV valve.

ASV-PV valves can control the differential pressure in several ranges if different pressure is needed.

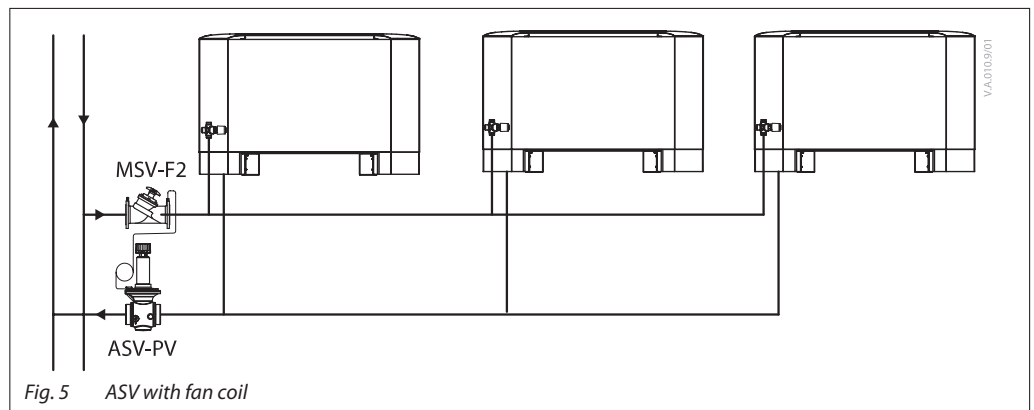

Fig. 5 ASV with fan coil

The ASV valves are to be used in systems with fan coils, induction devices and air-heaters to secure an automatic hydronic balance by the means of differential pressure control in branches or at every coil.

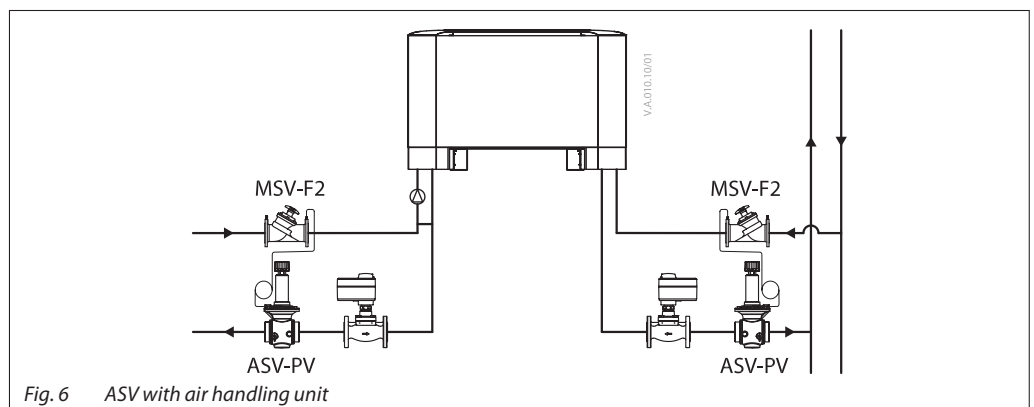

Fig. 6 ASV with air handling unit

The ASV valves are to be used in air handling units to secure an automatic hydronic balance by the means of differential pressure control at every unit.

Sizing

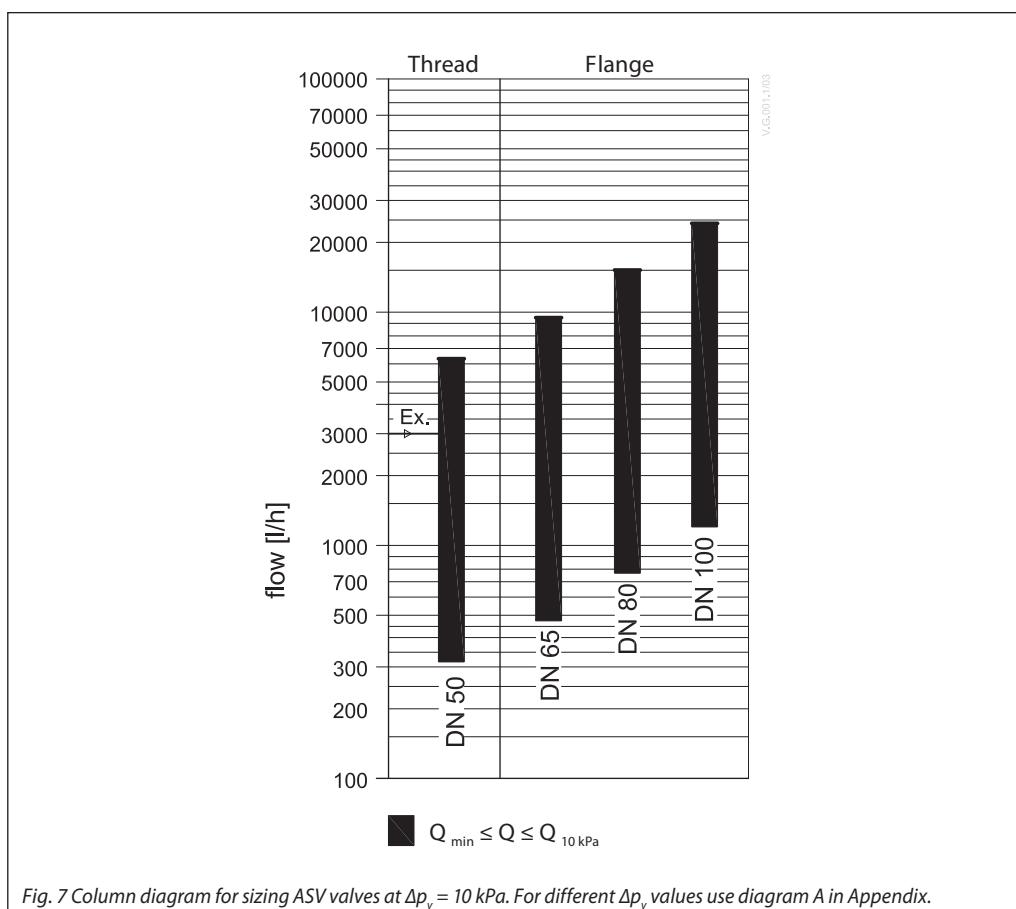

Fig. 7 Column diagram for sizing ASV valves at  $\Delta p_v = 10 \text{ kPa}$ . For different  $\Delta p_v$  values use diagram A in Appendix.

We recommend to size the diameter of ASV-PV valves by using Fig 7. Maximum flow rates are based on 10 kPa differential pressure over the valve which allows efficient pumping and saves energy.

After ASV-PV valves have been sized the same dimension of partner valve MSV-F2 valve should be selected.

**Example:**

*Given:*  
Pipe flow 3000 l/h, pipes DN 50

*Solution:*  
Horizontal line intersects the column for the valve DN 50 which can therefore be selected as required size.

For detailed sizing see examples on pages 9. For different  $\Delta p_v$  (differential pressure over the valve) see diagrams in Appendix A.

**Connection between valves size and pipe size**

$K_v$  values per particular dimension were designed to cover flow range according to VDI 2073 with water velocity of up to 0.8 m/s, at differential pressure of 10 kPa over the valve. As long as the water velocity in the pipe is between 0.3 and 0.8 m/s dimension of the valve should be equal to pipe dimension.

This rule is derived out of the fact that  $K_v$  values per particular dimension were designed to cover flow range according to VDI 2073 at differential pressure of 10 kPa over the valve.

Ordering

**ASV-PV** balancing valve, inclusive in the box:  
2.5 m impulse tube (G 1/16 A) drain connection (G 3/4 A) and adapter **003L8151**

Type	DN	k <sub>vs</sub> (m <sup>3</sup> /h)	Connection		Δp setting range (kPa)	Code No.
	50	20	External thread ISO 228/1	G 2 1/2	5-25	<b>003Z0611</b>
					20-40	<b>003Z0621</b>
					35-75	<b>003Z0631</b>
					60-100	<b>003Z0641</b>

**ASV-PV** balancing valve, inclusive in the box:  
2.5 m impulse tube (G 1/16 A), adapter ASV large **003Z0691** and **003L8151**

Type	DN	k <sub>vs</sub> (m <sup>3</sup> /h)	Connection	Δp setting range (kPa)	Code No.
	65	48	Flange EN 1092-2	20-40	<b>003Z0623</b>
	80	63			<b>003Z0624</b>
	100	76.0			<b>003Z0625</b>
	65	48		35-75	<b>003Z0633</b>
	80	63			<b>003Z0634</b>
	100	76.0			<b>003Z0635</b>
	65	48		60-100	<b>003Z0643</b>
	80	63			<b>003Z0644</b>
	100	76.0			<b>003Z0645</b>

**MSV-F2** Partner valve with shut-off, flowlimitation and test plugs. <sup>1)</sup>

Type	DN	k <sub>vs</sub> (m <sup>3</sup> /h)	T <sub>MAX.</sub> (°C)	DN20 (bar)	Code No.
	15	3.1	130	16	<b>003Z1085</b>
	20	6.3			<b>003Z1086</b>
	25	9.0			<b>003Z1087</b>
	32	15.5			<b>003Z1088</b>
	40	32.3			<b>003Z1089</b>
	50	53.8			<b>003Z1061</b>
	65	93.4			<b>003Z1062</b>
	80	122.3			<b>003Z1063</b>
	100	200.0			<b>003Z1064</b>

<sup>1)</sup> For more information see MSV-F2 datasheet

Accessories and spare parts

Description	Comments/connection	Code No.
Shut off knob for MSV-F2	DN 50	<b>003Z0179</b>
	DN 65-100	<b>003Z0180</b>
Differential pressure measuring connector	For drain connection	<b>003L8143</b>
Impulse tube, with O-rings	1.5 m	<b>003L8152</b>
	2.5 m	<b>003Z0690</b>
	5 m	<b>003L8153</b>
Plastic impulse tube with connectors and adapters	For making set of 10 pieces <sup>4)</sup>	<b>003Z0689</b>
Adapter large ASV <sup>1)</sup>	G 1/4-R 1/4; G 1/16	<b>003Z0691</b>
Plug for connecting impulse tube <sup>2)</sup>	G 1/16-R 1/4	<b>003L8151</b>
O-ring for impulse tube <sup>3)</sup>	2.90 × 1.78	<b>003L8175</b>

<sup>1)</sup> Recommended for use with MSV-F2, connected to measuring hole, it allows connection of impulse tube from ASV while retaining measurement functionality.

<sup>2)</sup> Recommended for use with MSV-F2, connected to measuring hole. Can also be used for connecting impulse tube directly on the pipe.

<sup>3)</sup> Set of 10 pieces.

<sup>4)</sup> Total 15 meter of impulse tube

Fitting

For valves with external thread Danfoss offers threaded or welded tailpieces as accessory.

Materials	
Nut	brass
Tailpiece welding	steel
Tailpiece threaded	brass

Type	Comment	to pipe	to valve	Code No.
	Tailpiece threaded (1 pcs.)	R2	DN 50 (2 1/4")	<b>003Z0274</b>
			DN 50 (2 1/2")	<b>003Z0278</b>
	Tailpiece welding (1 pcs.)	DN 50	DN 50 (2 1/4")	<b>003Z0272</b>
			DN 50 (2 1/2")	<b>003Z0276</b>

Technical data

Type		ASV-PV	MSV-F2 <sup>1)</sup>
Nominal diameter	DN	50-100	50-100
Max. pressure	bar	16 (PN 16)	16 (PN 16)
Test pressure		25	25
Differential pressure over the valve	kPa	10-250 <sup>2)</sup>	10-150
Temperature	°C	-10 ... 120	-10 ... 130
<b>Material of parts in contact with water</b>			
Valve body		Grey cast iron EN-GJL-250 (GG 25)	Cast iron EN-GJL 250 (GG 25)
Cone		Stainless steel	CW602N
Membrane / O-rings		EPDM	
Spring		Stainless steel	-

<sup>1)</sup> For more information see MSV-F2 datasheet.

<sup>2)</sup> Please note that the maximum admissible differential pressure across the valve 250 kPa should also not be exceeded at partial load.

Design

1. Shut-off knob
2. Differential pressure setting spindle
3. O-ring
4. Reference spring
5. Impulse tube connection
6. Diaphragm element
7. Control diaphragm
8. Pressure-relieved valve cone
9. Valve body
10. Seat

n (turns)	5-25 (kPa)	20-40 (kPa)	35-75 (kPa)	60-100 (kPa)
0	25	40	75	100
1	24	39	73	98
2	23	38	71	96
3	22	37	69	94
4	21	36	67	92
5	20	35	65	90
6	19	34	63	88
7	18	33	61	86
8	17	32	59	84
9	16	31	57	82
10	15	30	55	80
11	14	29	53	78
12	13	28	51	76
13	12	27	49	74
14	11	26	47	72
15	10	25	45	70
16	9	24	43	68
17	8	23	41	66
18	7	22	39	64
19	6	21	37	62
20	5	20	35	60

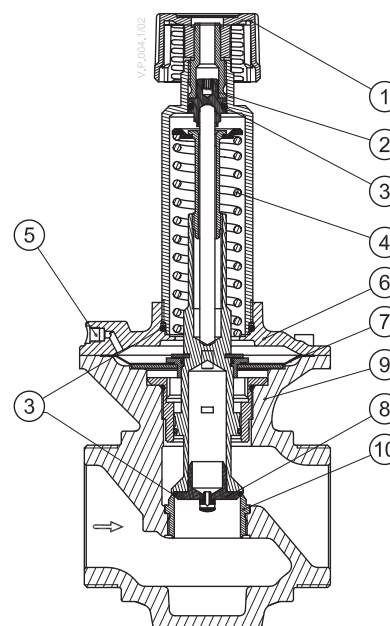

Factory presetting

Δp setting range (kPa)	kPa
5-25	10
20-40	30
35-75	60
60-100	80

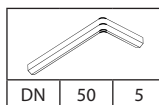

Fig. 8 ASV-PV (DN 50)

ASV-PV is designed to maintain a constant set differential pressure. Via an internal connection and together with the reference spring (4), pressure in the return pipe acts on the underside of the control diaphragm (7) while via an impulse tube (5), pressure in the flow pipe acts on the top of the diaphragm. In this way the balancing valve maintains adjusted differential pressure.

The ASV-PV valves are sold in four different Δp setting ranges. The valves are factory-set to a defined value as described on Factory presetting table on Fig. 8 and 9.

Use the following procedure to set the desired differential pressure:  
 the setting on ASV-PV can be changed by turning the setting spindle (2).  
 Turning the spindle clockwise increases the setting; turning it counter clockwise reduces the setting.

If the setting is not known, turn the spindle fully clockwise. With this the setting on ASV-PV is at maximum value within setting range. Now turn the spindle a number of times (n) as described in Fig. 6, 7 or 8 until the required differential pressure setting is obtained.

Design (continuous)

1. Shut-off knob
2. Differential pressure setting spindle
3. O-ring
4. Flat gasket
5. Reference spring
6. Impulse tube connection
7. Diaphragm element
8. Control diaphragm
9. Pressure-relieved valve cone
10. Valve body
11. Seat
12. Measuring holes-plugged
13. Air-vent

	65	13
DN	80	13
	100	13

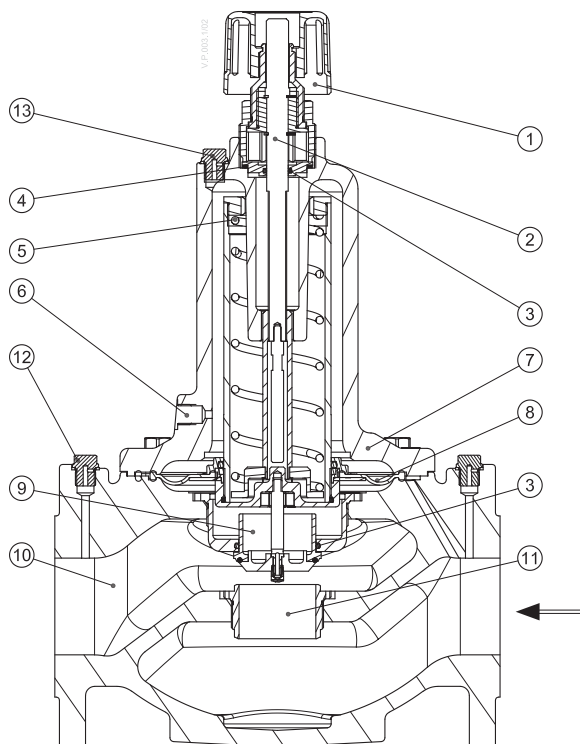

Factory presetting

Δp setting range (kPa)	kPa
20-40	30
35-75	60
60-100	80

n (turns)	20-40 (kPa)	35-75 (kPa)	60-100 (kPa)
0	40	75	100
1	39	74	99
2	38	73	98
3	37	72	97
4	36	71	96
5	35	70	95
6	34	69	94
7	33	68	93
8	32	67	92
9	31	66	91
10	30	65	90
11	29	64	89
12	28	63	88
13	27	62	87
14	26	61	86
15	25	60	85
16	24	59	84
17	23	58	83
18	22	57	82
19	21	56	81
20	20	55	80

n (turns)	20-40 (kPa)	35-75 (kPa)	60-100 (kPa)
21		54	79
22		53	78
23		52	77
24		51	76
25		50	75
26		49	74
27		48	73
28		47	72
29		46	71
30		45	70
31		44	69
32		43	68
33		42	67
34		41	66
35		40	65
36		39	64
37		38	63
38		37	62
39		36	61
40		35	60

Fig. 9 ASV-PV (DN 65-100)

**Design** (continuous)

- 1. Body EN-GJL250
- 2. Plug
- 3. Valve cone
- 3.1 . Seat soft sealing
- 4. Rod
- 5. Stroke limiter/Allen screw
- 6. Gasket
- 7. Handwheel with display - DN 50-100 plastic
- 8. Fixed screw
- 9. Spindle
- 10. Stuffing box
- 11. Bonnet
- 12. Allen screw /Hexagon screw
- 13. Flat gasket

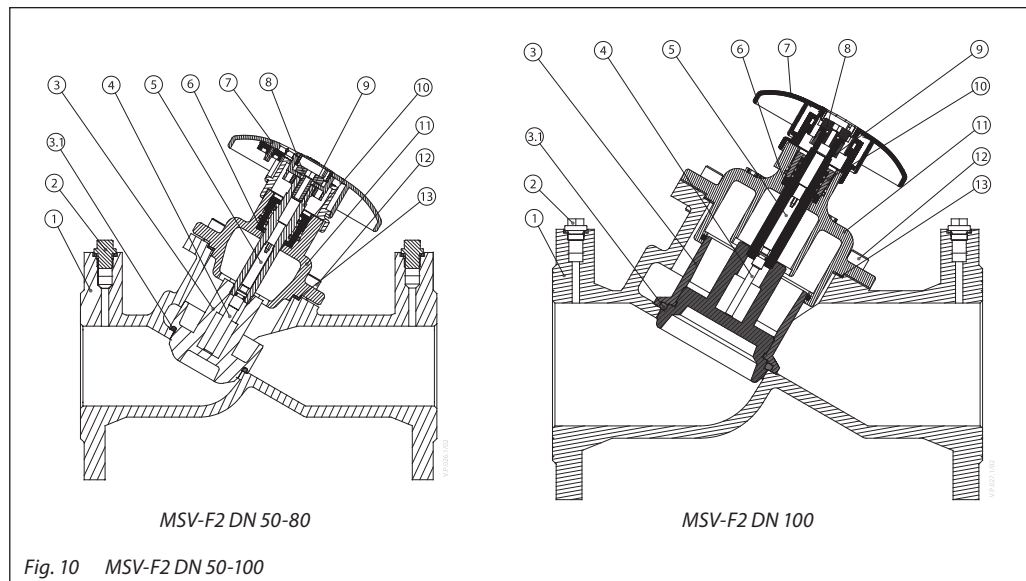

Fig. 10 MSV-F2 DN 50-100

**Partner valves** MSV-F2 <sup>1)</sup> are to be used together with the automatic balancing valves ASV-PV to control differential pressure in the risers.

**Impulse tube connection**

The impulse line must be connected to impulse tube connection piece (2) (adaptor sold as accessory). In working position, one of test plugs needs to be open while other closed. There are two possible configurations, with partner valve inside or outside control loop. It can be chosen by impulse tube connection side:

- Partner valve outside controlled loop: opened outlet test plug
- Partner valve inside controlled loop: opened inlet test plug

**MSV-F2** is manual presetting and shut-off valves. The valves have position indicator and stroke limiter as standard. Hood of spindle is integrated with stroke limiter. Setting can be locked.

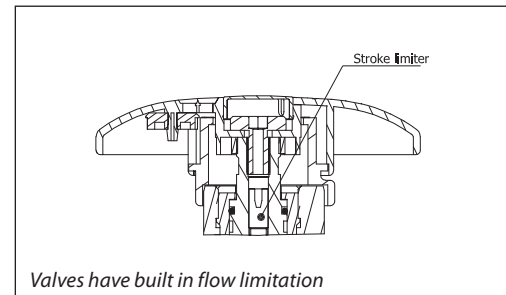

<sup>1)</sup> For more information see MSV-F2 datasheet



Sizing-design examples

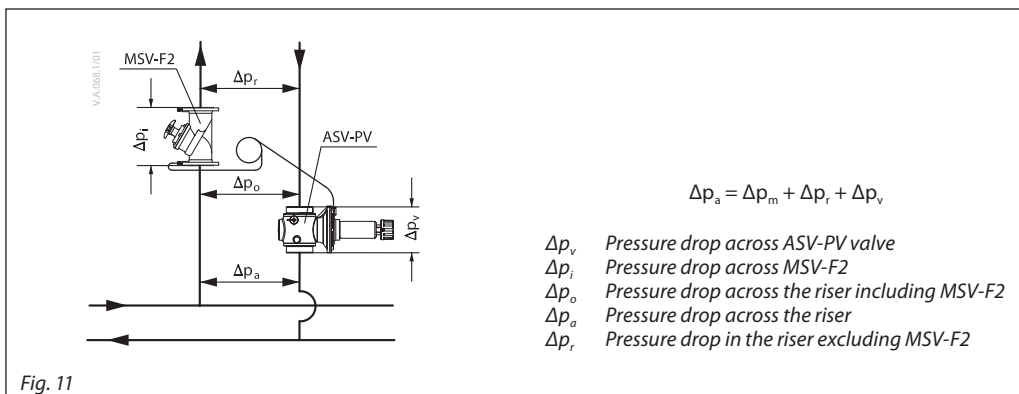

Fig. 11

**1. Example (AHU - air handling unit)**

Given:

- Desired flow for the riser (Q):..... 15 m<sup>3</sup>/h
- Minimal available pressure for that riser (Δp<sub>a</sub>) ..... 100 kPa
- Estimated pressure drop over the riser at the desired flow (Δp<sub>o</sub>) ..... 40 kPa

Wanted:

- Valve type
- Valve size

Selection and sizing of automatic balancing valves for air handling unit. The customer have chosen ASV-PV with partner valve MSV-F2 inside the control loop is chosen. Since the calculated pressure drop over the riser is 40 kPa ASV-PV with setting range between 35-75 kPa is selected. The minimal available pressure for the riser is 100 kPa and pressure drop across ASV-PV (Δp<sub>v</sub>) will following be 60 Kpa

$$\Delta p_v = \Delta p_a - \Delta p_o = 100 - 40 = 60 \text{ kPa}$$

$$k_v = \frac{Q}{\sqrt{\Delta p_v}} = \frac{15}{\sqrt{0.6}} = 19.36 \text{ m}^3/\text{h}$$

Based on this calculation ASV-PV DN 65 is selected with partner valve MSV-F2 also DN65. Set the valve to 40 kPa, see figure 11 (40kPa = 35 turns). Selection can also be made by reading from diagram Appendix A. fig A

**2. Example (continued AHU - air handling unit)**

Given:

Correcting the flow with the differential pressure setting.

- Desired flow for the riser (Q<sub>2</sub>): ..... 15 m<sup>3</sup>/h
- Measured flow for the riser (Q<sub>1</sub>) ..... 18 m<sup>3</sup>/h

Estimated pressure drop over the riser at desired flow (Δp<sub>r</sub>) ..... 40 kPa

Required:

Correct flow to 15 m<sup>3</sup>/h for the riser.

Solution:

Measuring the flow show that it is higher then what is desired for the riser, this could be caused by the real pressure drop over the riser is higher than the estimated 40 kPa, following setting on the ASV-PV valve can be adjusted to limit the flow.

$$P_2 = P_1 \times \left(\frac{Q_2}{Q_1}\right)^2 = 40 \times \left(\frac{15}{18}\right)^2 = 28 \text{ kPa}$$

If we decrease the setting from 40 to 28 kPa flow will be decreased to 15 m<sup>3</sup>/h.

Alternatively, flow limitation inside the loop can also be done with MSV-F2 by adjusting the setting of the valve.

**Measurement of flow and differential pressure**

MSV-F2 is equipped with two test plugs so that the differential pressure across the valve can be measured using Danfoss measuring equipment or any other measuring device. Valve can be converted to actual flow.

**Note:** When measuring sized flow, all radiator valves must be fully open (nominal flow).

**Measurement of differential pressure ( $\Delta p$ ) across riser.**

Fit a measuring connector (Danfoss code no. **003L8143**) on the ASV-PV balancing valve drain connection (DN 50) or threaded connection closer to the terminal unit (TU). Measurements must be taken between the test plug at MSV-F2 valve port B and the measuring connector on the ASV-PV.

**Installation**

ASV-PV must be installed in the return pipe with flow in the direction of the arrow on the valve body. Partner valves (MSV-F2) must be installed in the flow pipe, with flow in the direction of the arrow on the valve body. The impulse tube must be installed between partner valve and ASV-PV.

The impulse tube must be flushed through before installation. ASV-PV and MSV-F2 must in addition be installed as determined by installation conditions.

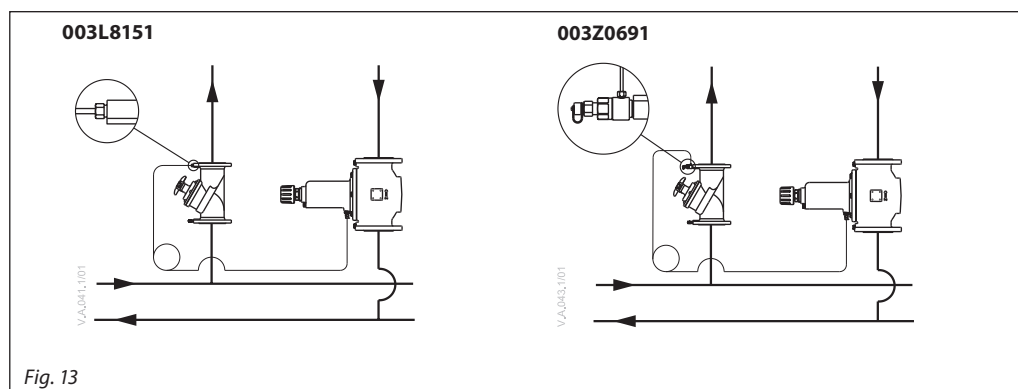

**Pressure testing**

Max. test pressure ..... 25 bar

When pressure testing the system you must secure that both sides of the membrane have the same static pressure to prevent damage of the pressure controller. That means the impulse tube must be connected and any needle valves must be open.

**Starting**

During system start – opening the shut-off on ASV-PV and partner valve-please secure that there is the same static pressure on both sides or higher pressure on upper side of the membrane. If filling is done by opening ASV-PV and partner valve, please make sure there is a pressure on the upper side of the membrane by opening partner valve first before ASV-PV is opened.

Dimensions

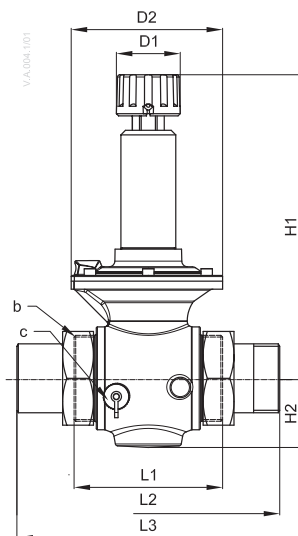

ASV-PV

DN	$\Delta p$ setting range	L1	L2	L3	H1	H2	D1	D2	b	c
	kPa									
50	5-25	130	244	234	232	61	55	133	G 2½	G ¾ A
	20-40									
	35-75									
	60-100				273					

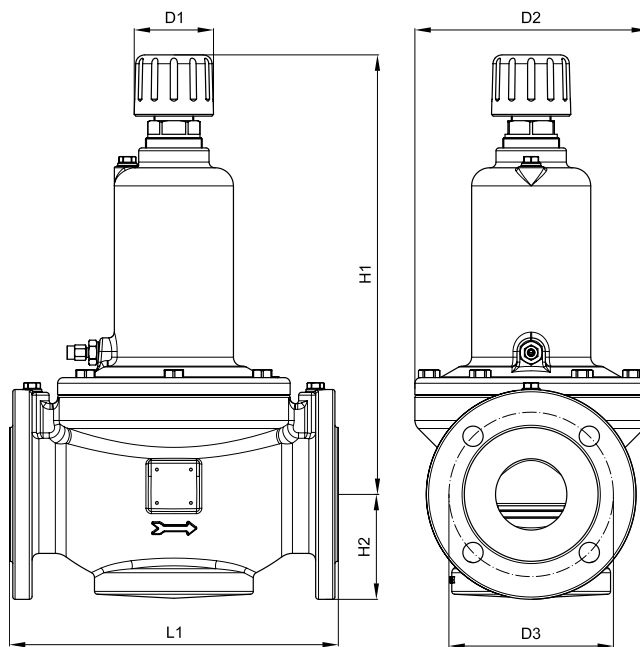

ASV-PV

DN	L1	H1	H2	D1	D2	D3
	mm					
65	290	385	93	68	205	145
80	310	390	100	68	218	160
100	347	446	112	68	248	180

Fig. 14

Appendix A-Sizing diagram

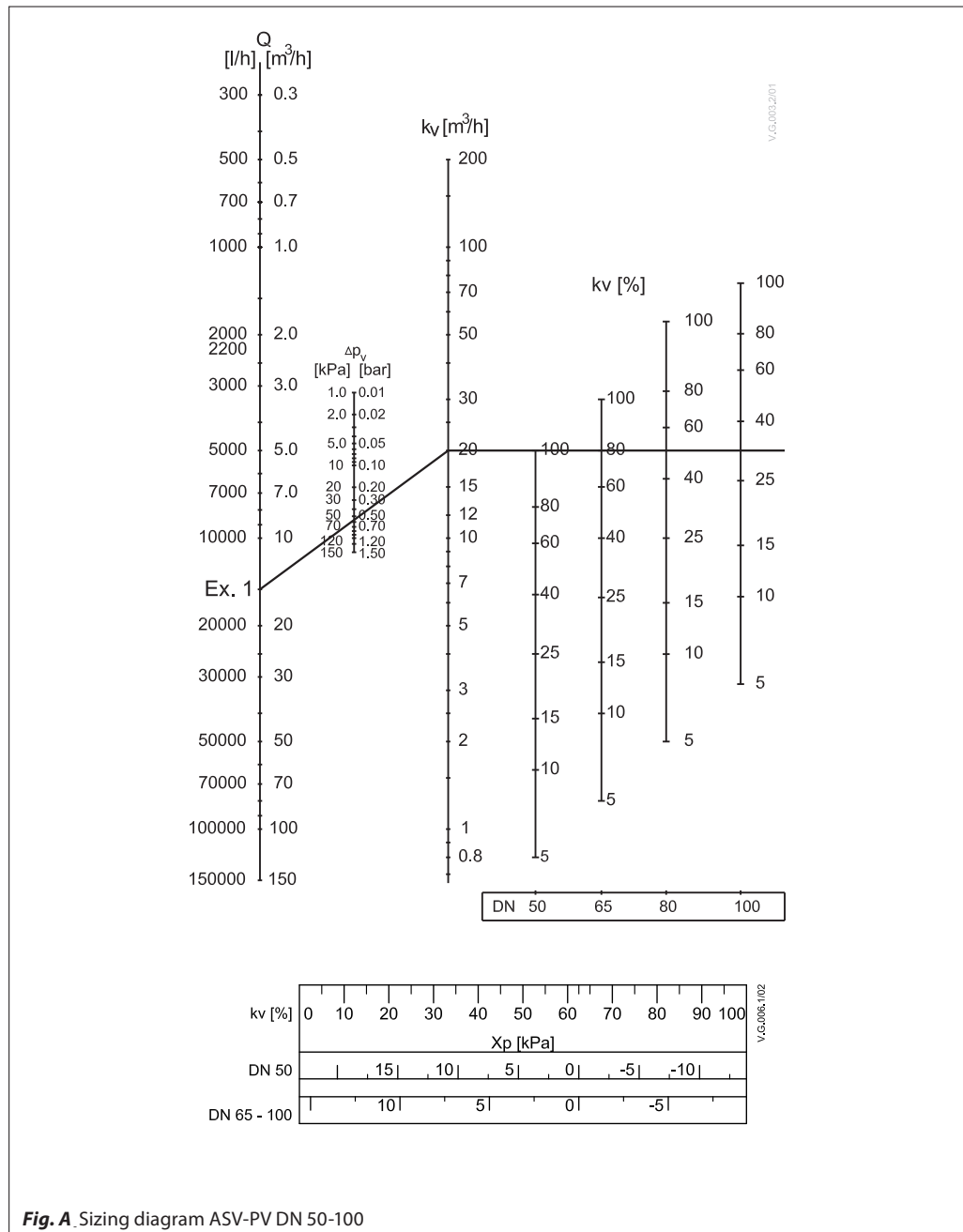
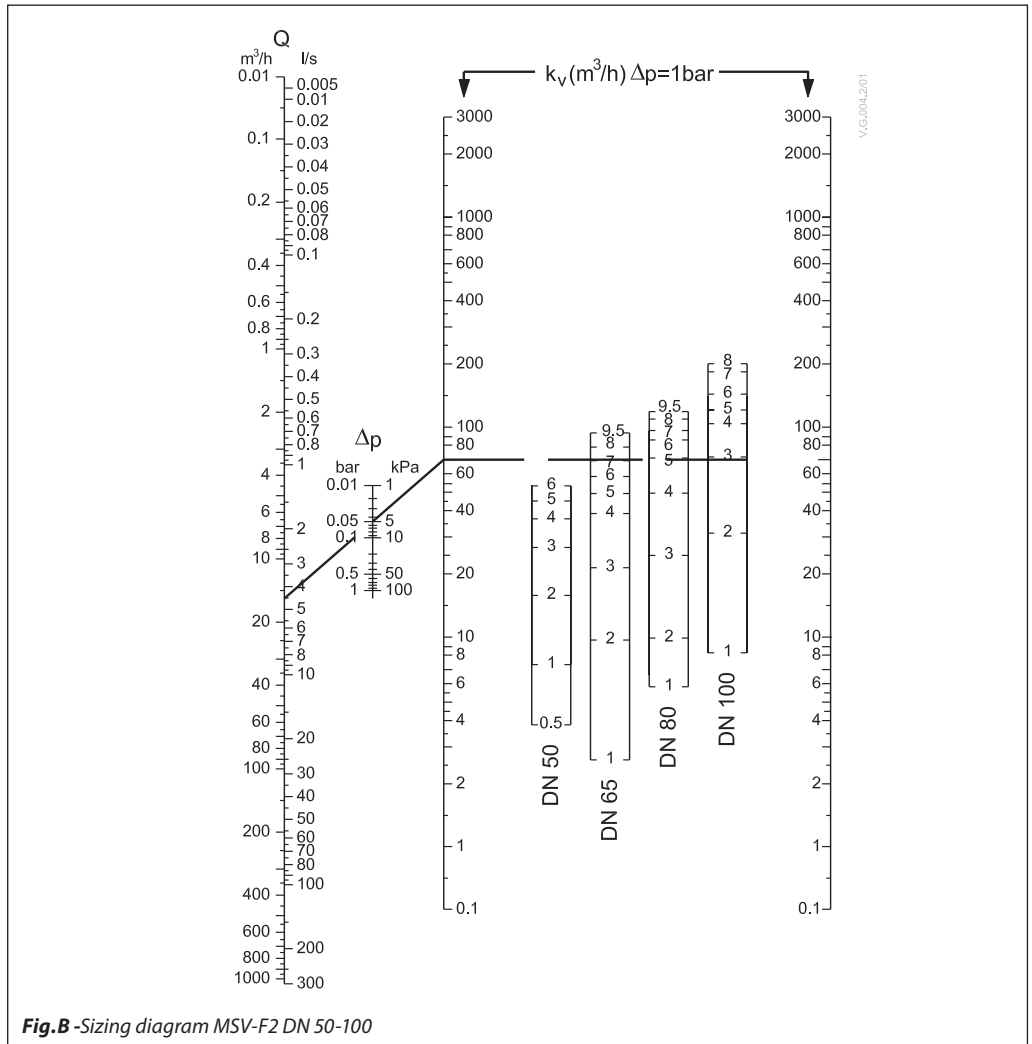
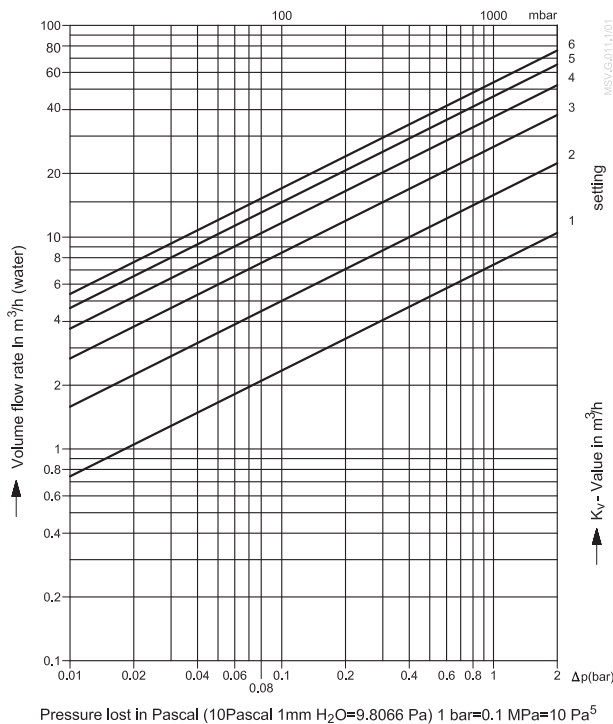

Fig. A Sizing diagram ASV-PV DN 50-100

Appendix A-Sizing diagram



Appendix B  
MSV-F Flow diagrams



DN 50 / PN 16 / PN 25

Setting	k <sub>v</sub> -value
1	7.4
2	15.8
3	26.7
4	36.9
5	46.2
6	53.8

Max. permissible differential pressure in throttling function 1.5 /2.0 bar.  
Max. permissible flow speed: ≤ 4 m/s  
Condition:

- The flow must be free of cavitation.

Flow characteristic

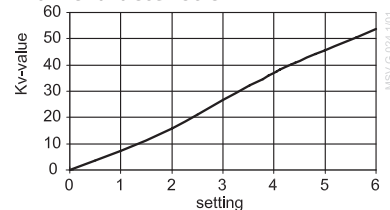

Appendix B (continued)  
MSV-F Flow diagrams

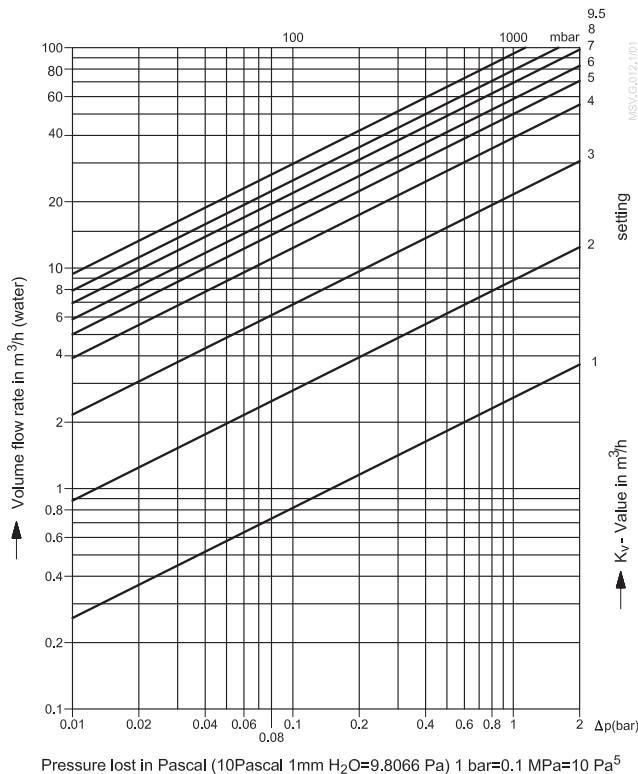

DN 65 / PN 16 / PN 25

Setting	k <sub>v</sub> -value
1	2.6
2	8.8
3	21.6
4	39.0
5	49.8
6	58.5
7	69.3
8	79.0
9	87.8
9.5	93.4

Max. permissible differential pressure in throttling function 1.5 / 2.0 bar.

Max. permissible flow speed: ≤ 4 m/s

Condition:

- The flow must be free of cavitation.

Flow characteristic

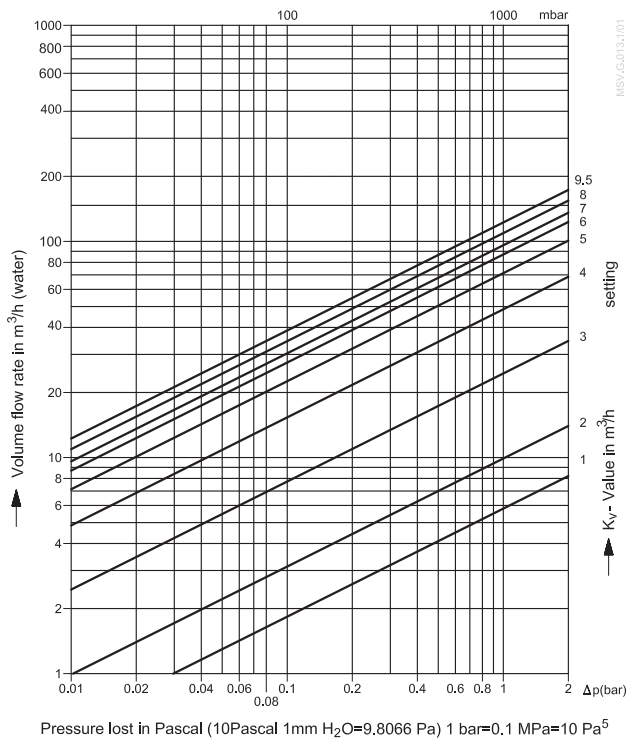
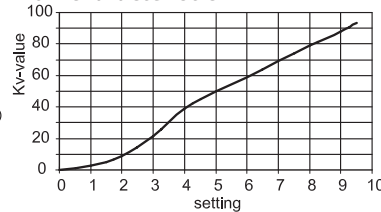

DN 80 / PN 16 / PN 25

Setting	k <sub>v</sub> -value
1	5.8
2	9.9
3	24.5
4	48.5
5	71.3
6	87.0
7	96.4
8	109.3
9.5	122.3

Max. permissible differential pressure in throttling function 1.5 / 2.0 bar.

Max. permissible flow speed: ≤ 4 m/s

Condition:

- The flow must be free of cavitation.

Flow characteristic

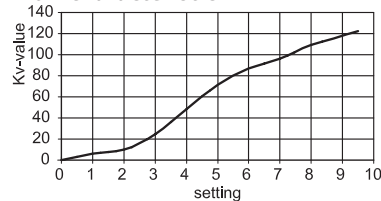

Appendix B (continued)  
MSV-F Flow diagrams

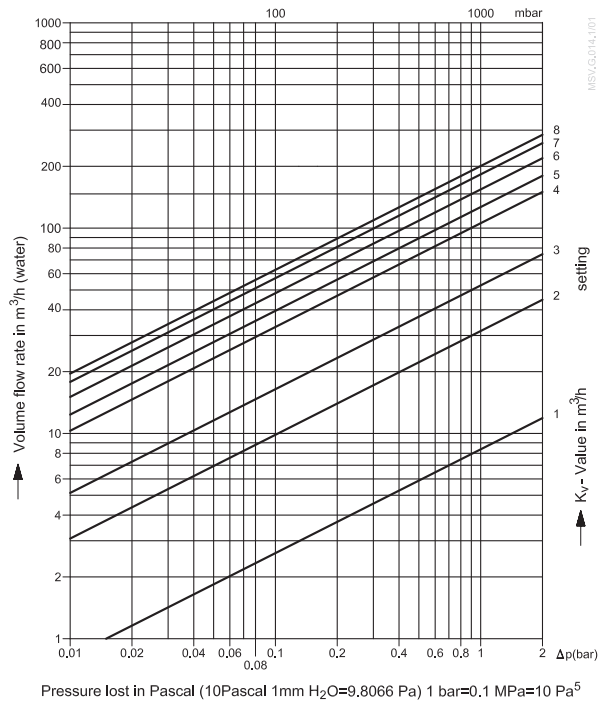

DN 100 / PN 16 / PN 25

Setting	k <sub>v</sub> -value
1	8.3
2	32.4
3	72.9
4	107.2
5	128.2
6	152.8
7	180.0
8	200.0

Max. permissible differential pressure in throttling function 1.5 / 2.0 bar.

Max. permissible flow speed: ≤ 4 m/s

Condition:

- The flow must be free of cavitation.

Flow characteristic

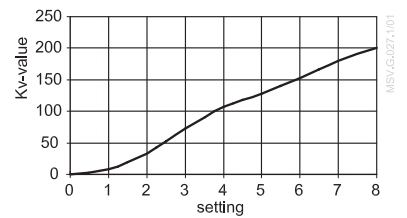



## ASV-PV tender text

**1. Tender text**

- a. Product is differential pressure controller for automatic hydronic balance of heating and cooling systems.
- b. The differential pressure controller should be based on integrated membrane element.
- c. Valves should have shut-off function separated from the setting mechanism. Shut-off service function should be possible with a hand knob.
- d. The setting of differential pressure should be hidden to prevent unauthorized change of setting.
- e. The differential pressure setting should be linear throughout the setting range (1 turn 1 kPa or 1 turn 2 kPa depending on dimension).
- f. Packaging of differential pressure controller should contain impulse tube (1.5 m)
- g. Valve should be delivered in reliable packaging for safe transport and handling.

**2. Product characteristics:**

- a. Pressure class: PN 16
- b. Temperature range: -10 ... +120 °C.
- c. Connection size: DN 50-100
- d. Connection type (depending on dp setting range): External thread ISO 228/1 (DN15-50) and Flange EN 1092-2 (DN 65-100)
- e.  $\Delta p$  setting range: 5-25 kPa (DN 50), 20-40 kPa (DN 50-100), 35-75 kPa (DN 50-100) and 60-100 kPa (DN 65-100).
- f. Installation: differential pressure controller should mounted on return pipe with connection via impulse tube to supply pipe.

Nominal diameter: -----  
Connection: -----  
Adjustment range from-to: ----- kPa  
Produced by: Danfoss Type: ASV-PV  
Ordering no.: **003L**---