

Data sheet

# Pressure switch and Thermostat

## CAS



The CAS Series consists of a series of pressure controlled switches and temperature controlled switches. In this series, special attention has been given to meeting demands for a high level of enclosure, robust and compact construction and resistance to shock and vibration.

The series is suitable for use in alarm and regulation systems in factories, diesel plants, compressors, power stations and on board ships.

### Features

- A high level of enclosure
- Fixed differential
- Robust and compact construction
- Resistance to shock and vibration
- Available with all major marine approvals

### Approvals

CE-marked in accordance with LVD 2006/95/EC

EN 60947-1, EN-60947-4-1, EN 60947-5-1

### Ship approvals

American Bureau of Shipping, ABS (excl. CAS 139)  
Lloyds Register of Shipping, LR (excl. CAS 1080)  
Germanischer Lloyd, GL  
Bureau Veritas, BV

Det Norske Veritas, DNV  
Registro Italiano Navale, RINA  
Maritime Register of Shipping, RMRS  
Nippon Kaiji Kyokai, NKK

Overview

Standard pressure switches

[bar]							Range P <sub>e</sub> [bar]	Type
0	10	20	30	40	50	60		
							0 – 3.5	CAS 133
							0 – 10	CAS 136
							0 – 18	CAS 137
							10 – 35	CAS 139

Pressure switches for high pressure and strongly pulsating media

[bar]							Range P <sub>e</sub> [bar]	Type
0	10	20	30	40	50	60		
							1 – 10	CAS 143
							4 – 40	CAS 145
							6 – 60	CAS 147

Differential pressure switches

[bar]							Range P <sub>e</sub> [bar]	Type
0	10	20	30	40	50	60		
							0.2 – 2.5	CAS 155

Thermostats

[°C]								Range [°C]	Type
0	20	40	60	80	100	120	140		
								20 – 80	CAS 178
								70 – 120	CAS 180
								60 – 150	CAS 181

## PRESSURE SWITCH

### Technical data

Switch	Microswitch with single pole changeover (SPDT)	
Contact load	Alternating current	AC-14 / AC-15: 0.1 A, 220 V
	Direct current	DC-13: 12 W, 125 V
Ambient temperature	CAS 133 – 139	-40 – 70 °C
	CAS 143 – 155	-25 – 70 °C
Temperature of medium <sup>1)</sup>	CAS 133 – 139	-40 – 100 °C
	CAS 143 – 155	-25 – 100 °C
Vibration resistance	Vibration-stable in the range 2 – 30 Hz amplitude 1.1 mm and 30 – 100 Hz, 4 g.	
Cable entry	Pg 13.5 for cable diameters from 5 – 14 mm.	

<sup>1)</sup>For water and seawater, max. 80 °C

### Materials in contact with the medium

Type	Materials	
<b>CAS 133, CAS 136, CAS 137, CAS 139</b>	Bellows:	Stainless steel, material no. 1.4306 (DIN 17440)
	Pressure connection:	Brass material no. 2.0401 (DIN 17660)
<b>CAS 143, CAS 145, CAS 147, CAS 155</b>	Diaphragm connection:	Nickel plated brass CuZn 40 Ob3 ISO R 426 (DIN 17569)
	Diaphragm:	Nitrile-butadien rubber

### Enclosure

IP67 acc. to EN 60529.

The pressure control housing is enamelled pressure die cast aluminium (GD-AISI 12).

The cover is fastened by four screws which are anchored to prevent loss.

The enclosure can be sealed with fuse wire.

### Identification

The type designation and code no. of the unit is stamped in the side of the housing.

**Ordering**
*Standard pressure switches*

Type	Setting range p <sub>e</sub> [bar]	Mechanical differential [bar]	Permissible operating pressure [bar]	Max test pressure [bar]	Min. burst pressure [bar]	Pressure connection	Code no.
CAS 133	0 – 3.5	0.1	10	10	40	G ¼	060-315066
CAS 136	0 – 10	0.2	22	22	40	G ¼	060-315166
CAS 137	6 – 18	0.3	27	27	72	G ¼	060-315266
CAS 139	10 – 35	0.6	53	53	100	G ¼	060-315366

*Pressure switches for high pressure and strongly pulsating media*

Type	Setting range p <sub>e</sub> [bar]	Mechanical differential [bar]	Permissible operating pressure [bar]	Max test pressure [bar]	Min. burst pressure [bar]	Pressure connection	Code no.
CAS 143	1 – 10	0.2 – 0.6	120	180	240	G ¼	060-316066
CAS 145	4 – 40	0.8 – 2.4	120	180	240	G ¼	060-316166
CAS 147	6 – 60	1 – 3	120	180	240	G ¼	060-316266

*Differential pressure switch*

Type	Setting range p <sub>e</sub> [bar]	Mechanical differential [bar]	Permissible operating pressure for low pressure [bar]	Max test pressure [bar]	Min. burst pressure [bar]	Pressure connection	Code no.
CAS 155	0.2 – 2.5	0.1	0 – 8	22	42	2 × G ¼	060-313066

Preferred version

**Terminology**
**Range setting**

The pressure range within which the unit will give a signal (contact changeover).

**Differential**

The difference between make pressure and break pressure (see also page 6).

**Permissible burst pressure**

The highest permanent or recurring pressure the unit can be loaded with.

**Max. test pressure**

The highest pressure the unit may be subjected to when, for example, testing the system for leakage. Therefore, this pressure must not occur as a recurring system pressure.

**Min. burst pressure**

The pressure which the pressure-sensitive element will withstand without leaking.

**Function**

**a. CAS 155**

Contacts 1-4 make and contacts 1-2 break when the differential pressure rises above the set range value. The contacts changeover to their initial

position when the differential pressure again falls to the range value minus the differential (see fig. 1).

- I. Alarm for rising pressure given at the set range value
- II. Alarm for falling pressure given at the set range value minus the differential

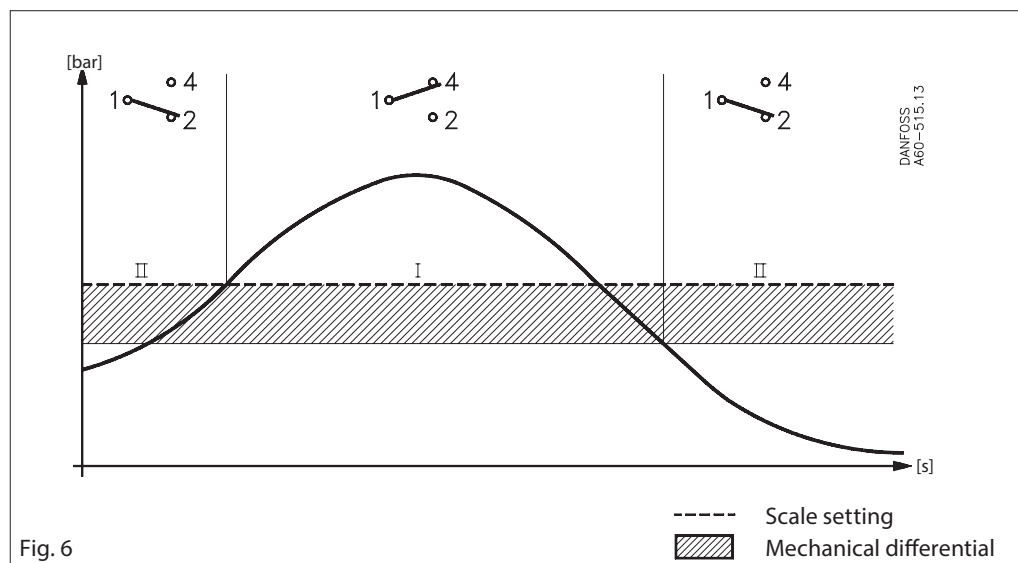

Fig. 6

**b. All other CAS pressure switches**

Contacts 1-2 make and contacts 1-4 break when the pressure falls under the set range value. The contacts changeover to their initial position

when the pressure again rises to the set range value plus the differential (see fig. 2).

- I. Alarm for rising pressure given at the set range value
- II. Alarm for falling pressure given at the set range value minus the differential

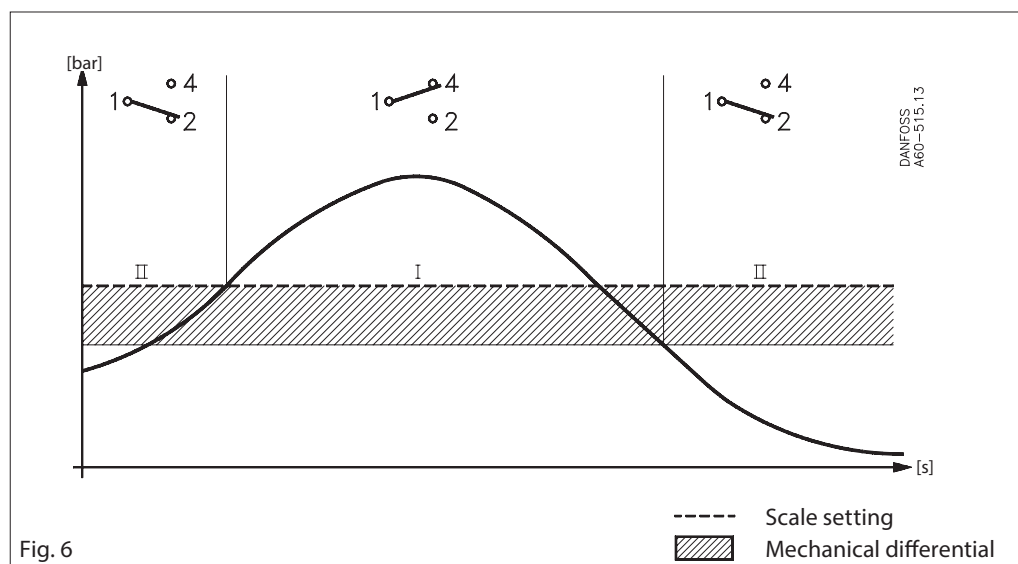

Fig. 6

**Example 1:**

An alarm must be given when the lubrication oil pressure in a motor falls below 0.8 bar. Select CAS 133 (range 0 – 3.5 bar). The minimum permissible lubricating oils pressure of 0.8 bar must be set using the range spindle. The differential is fixed at 0.1 bar, i.e. the alarm will not cut out before the pressure rises to 0.9 bar. The switch break function is normally used for alarm purposes, i.e. the alarm must be connected to terminals 1 and 4.

**Example 2:**

When the differential pressure exceeds 1.3 bar a filter must be cleaned. The maximum static pressure (LP) for the CAS 155 of 8 bar must not be exceeded. The pressure control range spindle must be set at 1.3 bar. The alarm must be connected to terminals 1 and 2 (alarm for broken circuit).

**Accessories**

Part	Description	Qty.	Code no.
<b>Connector with nipple</b> 	Pipe thread ISO 228-1, G $\frac{3}{8}$ connector, nipple and AL washer (10 mm ext. 8 mm int. diam) for solering onto steel or copper tubing, steel span of jaws 22	5	<b>017-436866</b>
<b>Connector with nipple</b> 	G $\frac{3}{8}$ connector, nipple and washer (10 mm ext./ 6.5 mm int. diam.) for welding, steel span of jaws 22	1	<b>017-422966</b>
<b>Reducer</b> 	Pipe thread ISO 228-1, G $\frac{3}{8}$ x $\frac{1}{4}$ - 20 UNF reducer, washer, brass span of jaws 22	5	<b>017-420566</b>
<b>Adaptor</b> 	Pipe thread ISO 228-1, G $\frac{3}{8}$ x $\frac{1}{4}$ - 27 NPT with copper washer brass span of jaws 22	1	<b>060-333466</b>
<b>Adaptor</b> 	Pipe thread ISO 228-1, G $\frac{3}{8}$ A x $\frac{1}{4}$ - 18 NPT with copper washer brass span of jaws 22	1	<b>060-333566</b>
<b>Adaptor</b> 	Pipe thread ISO 228-1, G $\frac{3}{8}$ A x $\frac{1}{4}$ - 18 NPT with copper washer brass span of jaws 22	1	<b>060-333666</b>
<b>Adaptor</b> 	$\frac{3}{8}$ - 20UNF x R $\frac{3}{8}$ (ISO 7-1) brass, span of jaws 19	1	<b>060-324066</b>
<b>Nipple</b> 	G $\frac{1}{4}$ A x G $\frac{3}{8}$ A		<b>060-333266</b>
	G $\frac{1}{4}$ A x ext. M10 x 1 with washer		<b>060-333866</b>
<b>Damping coil</b> 	Pipe thread ISO 228-1, damping coil with G $\frac{3}{8}$ connector and 1.5 m copper capillary tube. Standard washers are supplied.	1	<b>060-104766</b>
<b>Armoured damping coil</b> 	Pipe thread ISO 228-1, damping coil with G $\frac{3}{8}$ connector and 1 m copper capillary tube. Standard washers are supplied.	1	<b>060-333366</b>

Installation

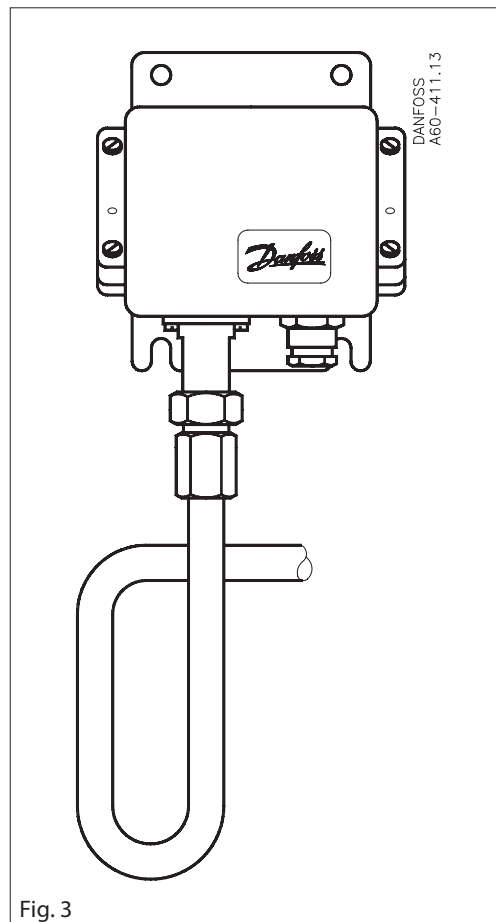

- 1. Range spindle
- 2. Range scale
- 3. Locking screw

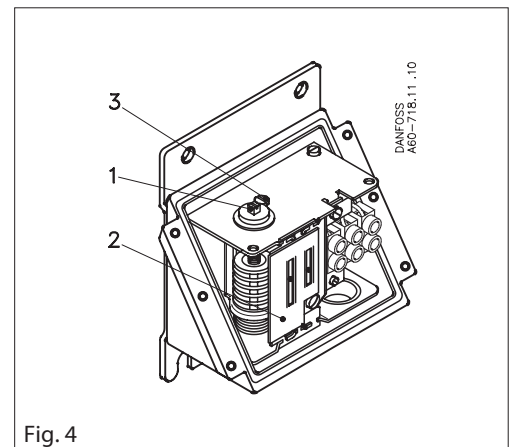

Fig. 4

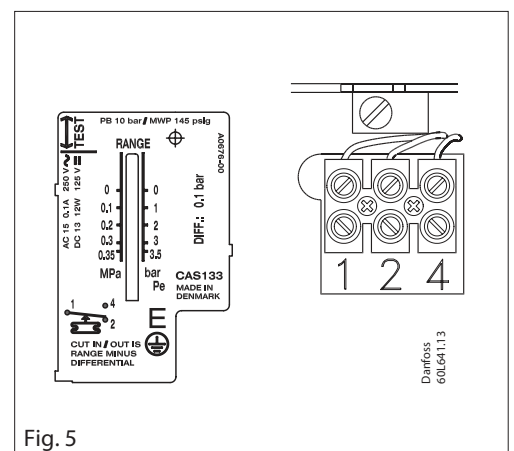

Fig. 5

**Installation**

CAS pressure switches are fitted with a 3 mm steel mounting plate. The units should not be allowed to hang from the pressure connection.

**Pressure connection**

When fitting or removing pressure lines, the spanner flats on the pressure connection should be used to apply counter-torque.

**Steam plant**

To protect the pressure element from excessive heat, the insertion of a water-filled loop is recommended. The loop can, for example, be made of 10 mm copper tube as shown in fig. 3.

**Water systems**

Water in the pressure element is not harmful, but in case of frost a water-filled pressure element may burst. To prevent this happening, the pressure control can be allowed to operate on an air cushion.

**Media resistance**

See table of materials in contact with the medium, page 3. If seawater is involved, types CAS 143, CAS 145, CAS 147, CAS 155 are recommended.

**Pulsations**

If the pressure medium is superimposed with severe pulsations, which occur in automatic sprinkler systems (fire protection), fuel systems for diesel motors (priming lines), and hydraulic systems (e.g. propeller systems), etc, types case CAS 143, CAS 145, CAS 147 are recommended.

The maximum permissible pulsation level for these types is 120 bar.

**Setting**

When the pressure switch cover is removed, and the locking screw (3) is loosened, the range can be set with the spindle (1) while at the same time the scale (2) is being read (fig. 4).

**Electrical connection**

CAS pressure switches are fitted with a PG 13.5 screwed cable entry that is suitable for cable diameters from 5 – 13 mm.

Contact function is shown in fig. 5.

Dimensions [mm]  
and weights [kg]

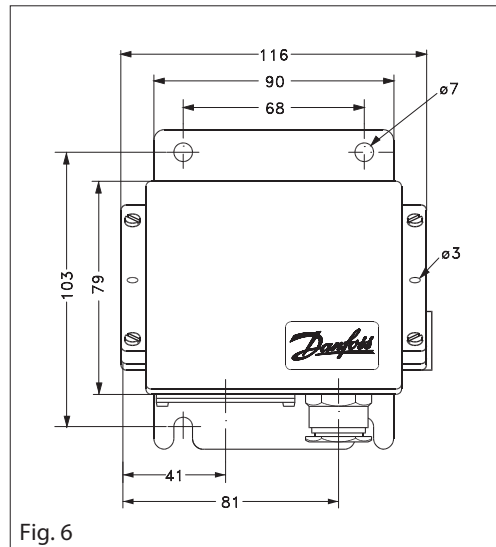

Fig. 6

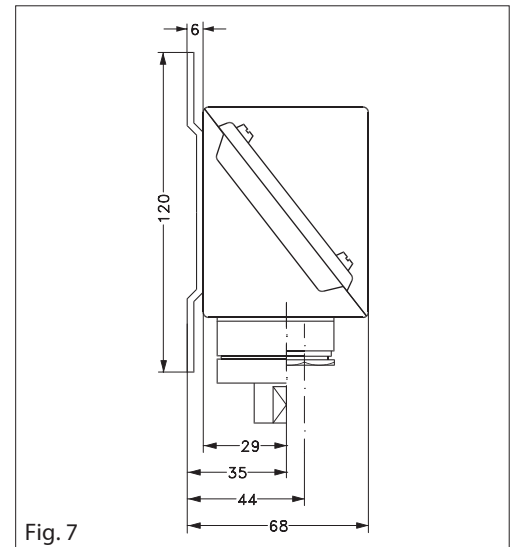

Fig. 7

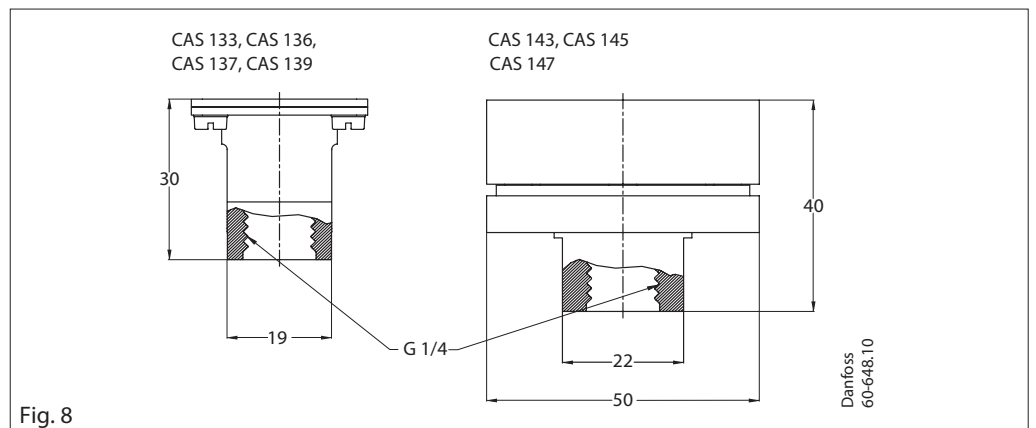

Fig. 8

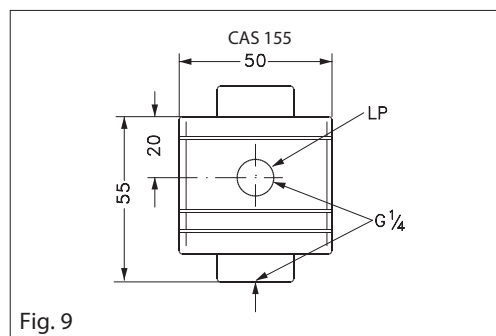

Fig. 9

Net weight:  
CAS 133-139 approx. 1.0 kg  
CAS 143-147 approx. 1.3 kg  
CAS 155 approx. 1.5 kg



## THERMOSTAT

### Technical data

Type		CAS 178, CAS 180, CAS 181	CAS 1080
Switch		Microswitch with single pole changeover (SPDT)	Microswitch with single pole changeover (2 x SPDT)
Contact load	Alternating current	AC-14 / AC-15: 0.1 A, 220 V	
	Direct current	DC-13: 12 W, 125 V	
Ambient temperature		-25 – 70 °C	
Vibration resistance		Vibration-stable in the range 2 – 30 Hz, amplitude 1.1 mm and 30 – 100 Hz, 4 g.	
Cable entry		Pg 13.5 for cable diameters from 5 – 14 mm	2 x g 13.5 for cable diameters from 5 – 14 mm

### Ordering

#### 2-step thermostat, type CAS 1080

Type	Setting range	Mechanical differential adjustable / fixed	Max. sensor temperature	Suitable sensor length (see also "Accessories")				Capillary tube length	Code no.
	[°C]			[°C]	[°C]	[mm]	[mm]		
CAS 178	20 – 80	2.0	130	65	75	110	160	2	060L315166
CAS 180	70 – 120	2.0	220	65	75	110	160	2	060L315366
CAS 181	60 – 150	2.0	250	65	75	110	160	2	060L315566

Type	Factory setting		Mechanical differential [°C]	Max. temperature [°C]	Insert sensor length [mm]	Code no.
	Step 1 [°C]	Step 2 [°C]				
CAS 1080	80	80	2.0	220	200	060L502066

Preferred version

#### Enclosure

IP67 acc. to EN 60529.  
The thermostat housing is enamelled pressure die cast aluminium (GD-AISI 12). The cover is fastened by four screws which are anchored to prevent loss.  
The enclosure can be sealed with fuse wire.

#### Identification

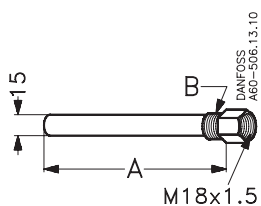

The type designation and code no. of the unit is stamped in the side of the housing.

**Accessories**

**Sensor pockets for thermostats**

Brass sensor pocket			Steel 18/8 sensor pocket		
A [mm]	Thread B	Code no.	A [mm]	Thread B	Code no.
65	½ NPT	<b>060L326566</b>	—	—	—
75	½ NPT	<b>060L326466</b>	75	G ½ A	<b>060L326766</b>
75	G ½ A	<b>060L326266</b>	—	—	—
75	G ¾ A	<b>060L326666</b>	—	—	—
75	G ½ A (ISO 228/1)	<b>060L328166</b>	—	—	—
110	½ NPT	<b>060L328066</b>	110	G ½ A	<b>060L326866</b>
110	G ½ A	<b>060L327166</b>	110	½ NPT	<b>060L327066</b>
110	G ½ A (ISO 228/1)	<b>060L340666</b>	—	—	—
110	G ¾ A (ISO 228/1)	<b>060L340366</b>	—	—	—
160	G ½ A	<b>060L326366</b>	160	G ½ A	<b>060L326966</b>
200	G ½ A	<b>060L320666</b>	—	—	—
200	G ½ A (ISO 228/1)	<b>060L340866</b>	—	—	—
200	G ¾ A (ISO 228/1)	<b>060L340266</b>	—	—	—
250	G ½ A	<b>060L325466</b>	—	—	—
330	G ½ A	<b>060L325566</b>	—	—	—

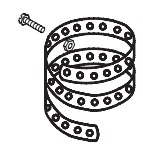
**Note:**

All sensor pockets are supplied without gland nut, gaskets and washes.

Other Accessories	Description	Qty./unit	Code no.
Clamping band	 For CAS temperature controls with remote sensor (L = 392 mm).	10	<b>017-420466</b>
Heat conductive compound (Tube with 4.5 cm <sup>3</sup> )	 For CAS with sensor fitted in a sensor pocket. For filling sensor pocket to improve heat transfer between pocket and sensor. Application range for compound: -20 – 150 °C, momentarily up to 220 °C.	1	<b>041E0114</b>

**Installation**

Location of unit: CAS thermostats are designed to withstand the shocks that occur, for example, in ships on compressors and in large machine installations. CAS thermostats are fitted with a base of 3 mm steel plate for fixing to bulkheads, etc.

**Resistance to media**  
Material specifications for sensor pockets.

**Sensor pocket brass**  
The tube is made of Ms 72 to DIN 17660, the threaded portion of So Ms 58 Pb to DIN 17661.

**Sensor pocket, stainless steel 18/8**  
Material designation 1.4305 to DIN 17440.

**Sensor position**  
As far as possible the sensor should be positioned so that its longitudinal axis is at right angles to the direction flow. The active part of the sensor is  $\varnothing 13 \text{ mm} \times 47.5 \text{ mm}$ .

**The medium**  
The fastest reaction is obtained from a medium having high specific heat and high thermal conductivity. It is therefore advantageous to use a medium that fulfils these conditions (provided there is a choice). The flow velocity of the medium is also of significance. (The optimum flow velocity for liquids is about 0.3 m/s). For permissible media pressure see fig. 10.

**Permissible media pressure on the sensor pocket as a function of temperature**

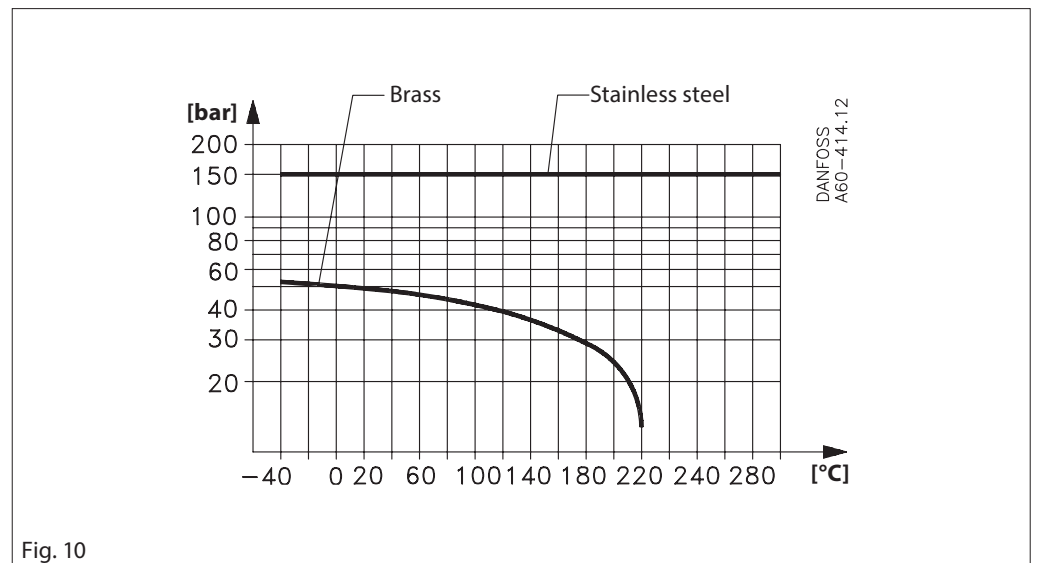

Fig. 10

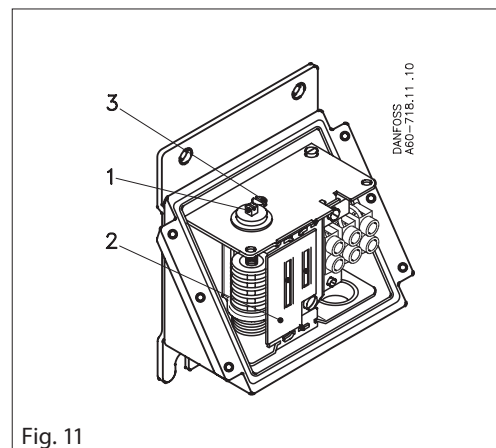

Fig. 11

**Setting**  
When the thermostat cover is removed, and the locking screw (3) fig. 2 is loosened, the range can be set with the spindle (1) while at the same time the scale (2) is being read (fig.11).

- 1. Range spindle
- 2. Range scale
- 3. Locking screw

**Installation**  
(continued)

**Scale correction**

The sensor on CAS thermostats contains an adsorption charge. Therefore function is not affected whether the sensor is placed warmer or colder than the remaining part of the thermostatic element (bellows and capillary tube).

However, such a charge is to some extent sensitive to changes in the temperature of bellows and capillary tube. Under normal conditions this is of no importance, but if the thermostat is to be used in extreme ambient temperatures there will be a scale deviation.

The deviation can be compensated for as follows:

$$\text{Scale correction} = Z \times a$$

Z can be found from fig. 12, while "a" is the correction factor from the table below.

(See example, page 14).

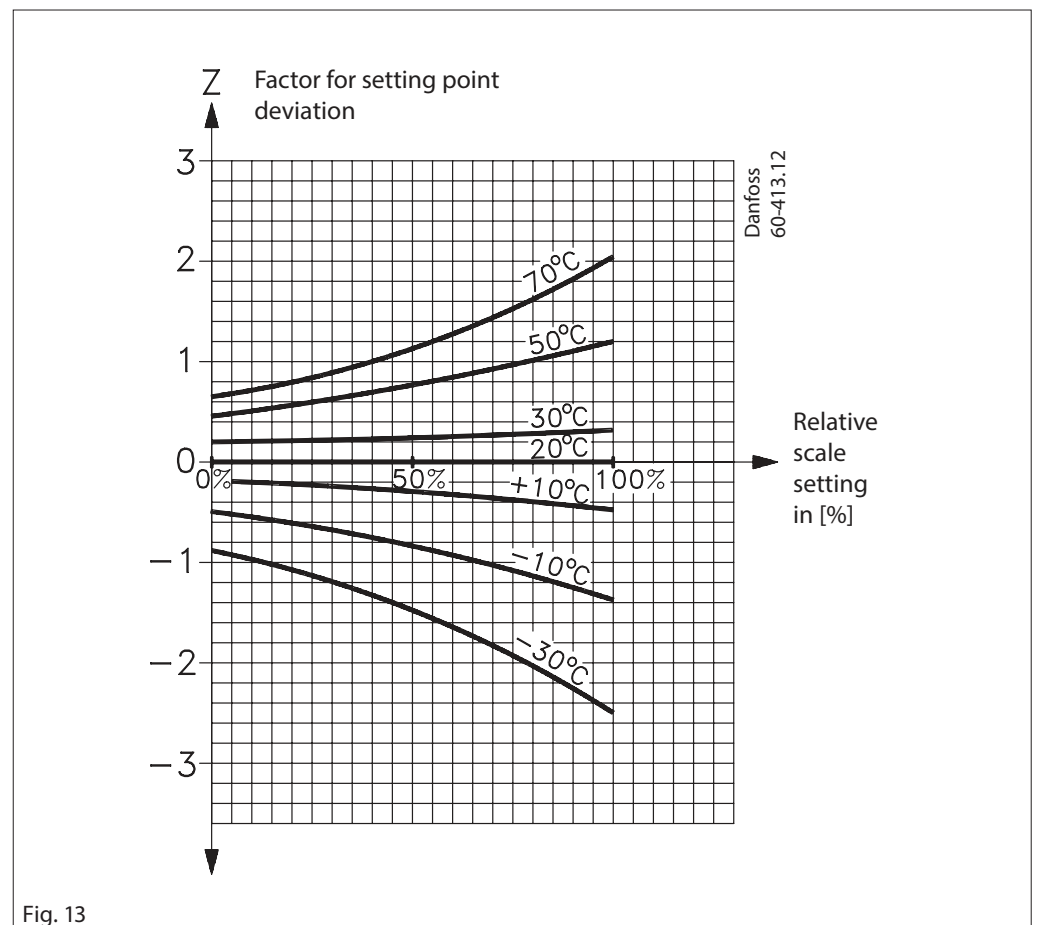

Fig. 13

Type	Regulation range [°C]	Correction factor a for thermostats
CAS 178	20 – 80	2.5
CAS 180	70 – 120	2.4
CAS 181	60 – 150	3.7

**Installation**  
(continued)

**Electrical connection**

CAS thermostats are fitted with a Pg 13.5 screwed cable entry suitable for cables from 5 – 14 mm.

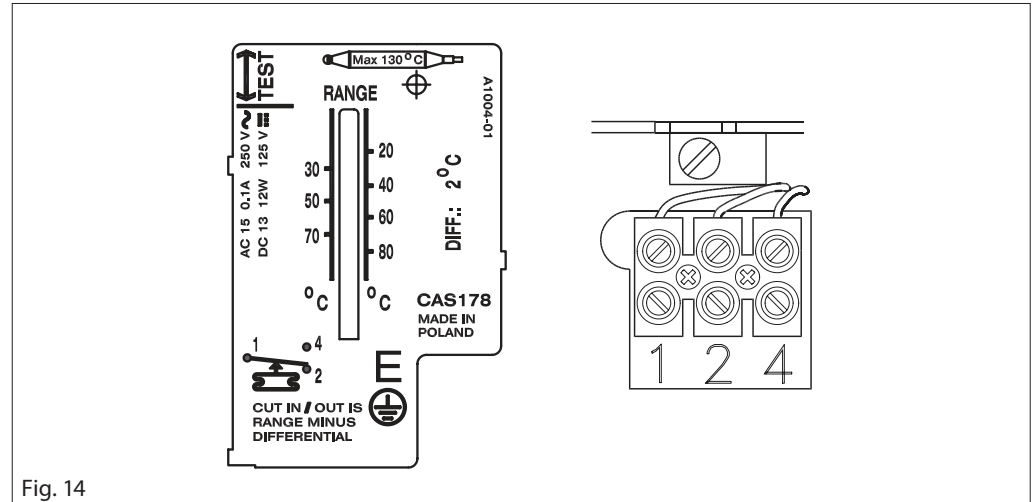

Fig. 14

2-step CAS thermostat, type CAS 1080

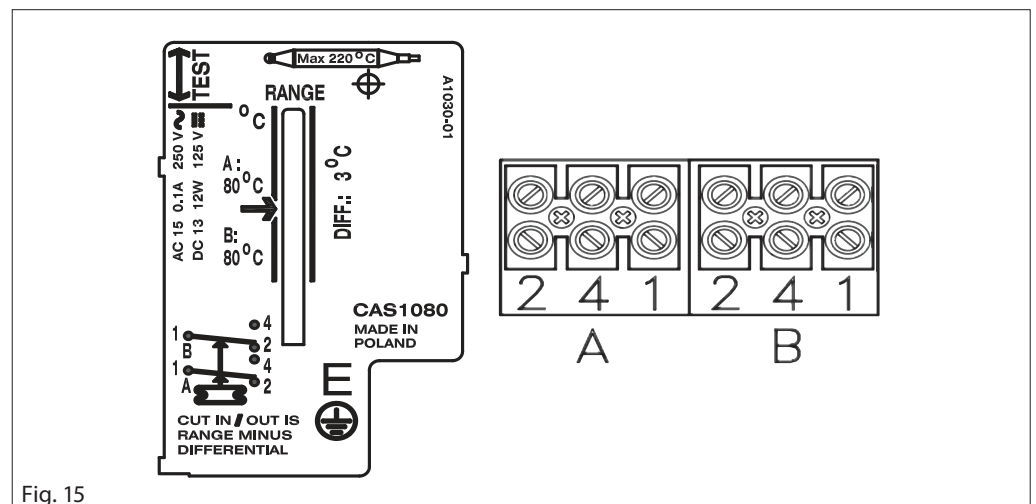

Fig. 15

**Function**

**Differentials**

The mechanical differential is the differential determined by the design of the thermostat. The thermal differential (operating differential) is the differential the system operates on.

The thermal differential is always greater than the mechanical differential and depends on three factors:

- 1) Medium flow velocity
- 2) Temperature change rate of the medium
- 3) Heat transmission to the sensor

**Thermostat function**

Contacts 1-4 make while contacts 1-2 break when the temperature rises above the scale setting.

The contacts changeover to their initial position when the temperature falls to the scale setting minus the differential. See fig. 16.

- I. Alarm for rising temperature given at range setting value.
- II. Alarm for falling temperature given at range setting value minus the differential.

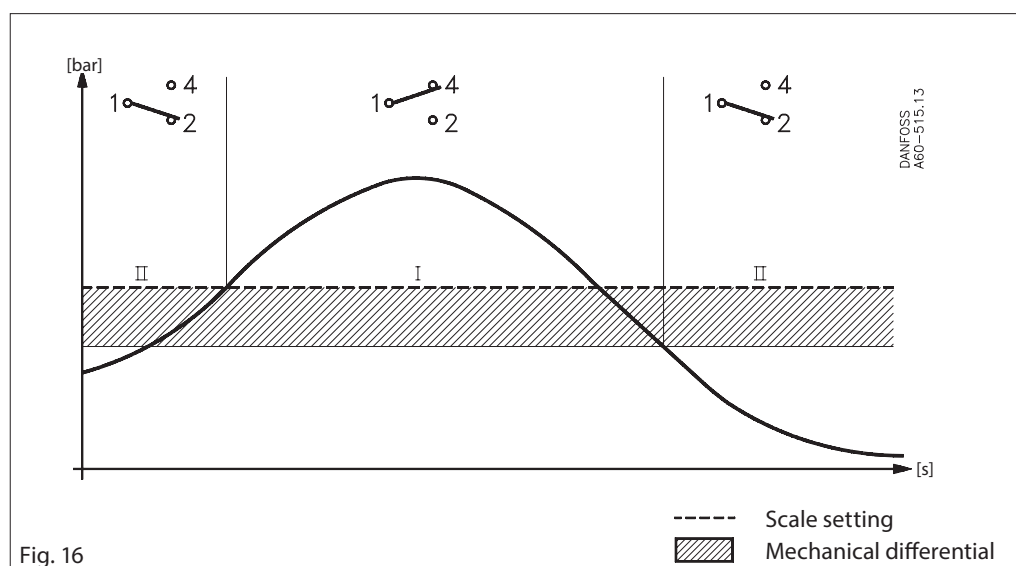

Fig. 16

**Example 1**

Diesel engine with cooling water temperature of 85 °C (normal). An alarm must be triggered if the cooling water temperature exceeds 95 °C. Choose a CAS thermostat 180 (range 70 – 120 °C). Main spindle setting: 95 °C.

The required alarm function is obtained by connecting to thermostat terminals 1-4.

**Example 2**

Find the necessary scale correction for a CAS 180. Set 95 °C at 50 °C ambient temperature.

The relative scale setting Z can be calculated from the following formula:

$$\frac{\text{Setting value} - \text{min. scale value}}{\text{max. scale value} - \text{min. scale value}} \times 100 = [\%]$$

Relative scale setting:  $\frac{95-70 \times 100}{120-70} = 50\%$

Factor for scale deviation Z fig. 12,  $Z \approx 0.7$   
 Correction factor "a=2.4", see table page 12.  
 Scale correction =  $Z \times a = 0.7 \times 2.4 = 1.7 \text{ °C}$   
 CAS must be set at  $95 + 1.7 = 96.7 \text{ °C}$

**Function**  
(continued)

CAS 1080 thermostats have fixed factory settings.

The thermostats with factory setting at 80 °C of step 1 and step 2 is used for special application, where double warning – like cranked case fire – is requested.

The contacts automatically reset when the temperature decreases in accordance with the differential.

**Differentials**

The mechanical differential is the differential determined by the design of the thermostat. The thermal differential (operating differential) is the differential the contact system operates on.

The thermal differential is always greater than the mechanical differential and depends on three factors:

- 1) Medium flow velocity
- 2) Temperature change rate of the medium and
- 3) Heat transmission to the sensor

**Thermostat function**

Contacts 1–4 make while contacts 1–2 break when the temperature rises above the scale setting.

The contacts changeover to their initial position when the temperature falls to the scale setting minus the differential. See fig. 17.

The contacts marked A correspond to step 1. The contacts marked B correspond to step 2.

- I. Alarm for rising temperature given at range setting value.
- II. Alarm for falling temperature given at range setting value minus the differential

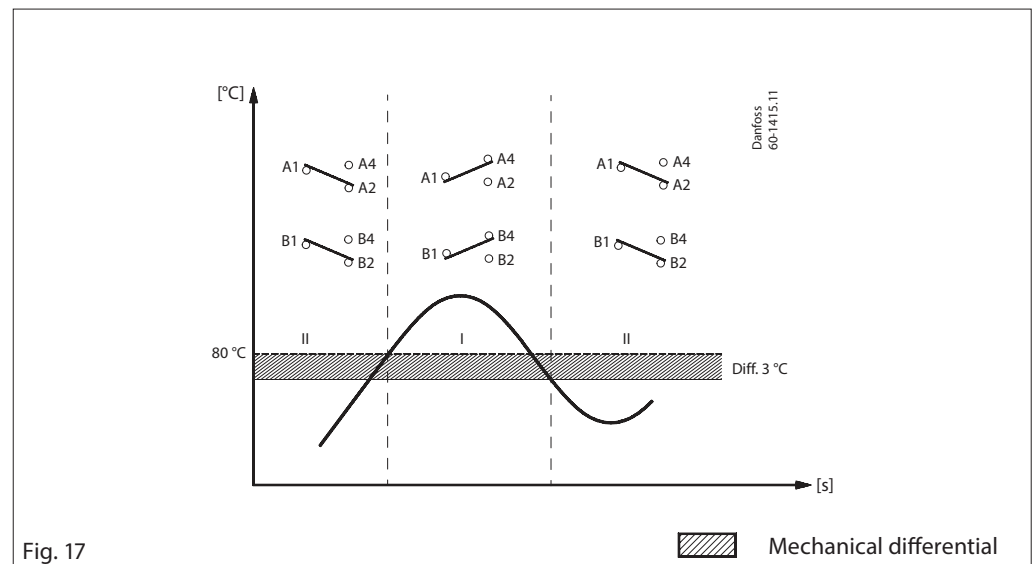
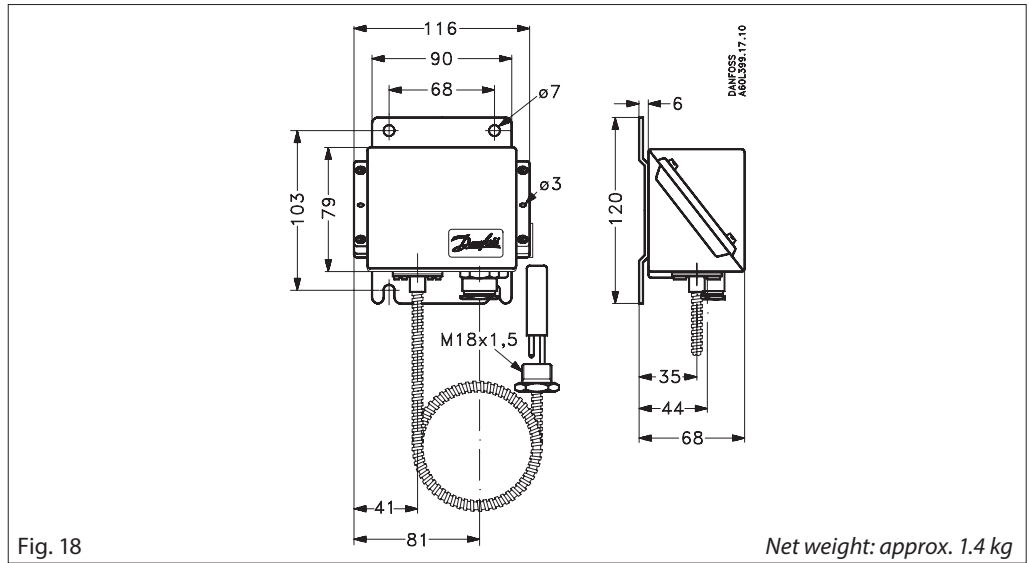

Fig. 17

Mechanical differential

**Dimensions [mm]  
and weights [kg]**

CAS with remote sensor and 2 m armoured capillary tube



2-step thermostat, type CAS 1080

