

Data sheet

## CLP/CLP D pumps

CLP-005-500 / CLP D-005-1000



Table of Contents

Contents	
1.	Introduction .....2
2.	Benefits.....4
3.	Application examples .....4
4.	Technical data .....5
4.1	CLP-005-017 .....5
4.2	CLP D-005-017 .....6
4.3	CLP-025-058 .....7
4.4	CLP D-025-058 .....8
4.5	CLP-055-080 .....9
4.6	CLP-085-152 .....10
4.7	CLP D-085-152 .....11
4.8	CLP-140-500 .....12
4.9	CLP D-140-500 .....13
4.10	CLP D-580-1000 .....14
5.	Pressure and flow .....15
5.1	CLP/CLP D-005-017 typical flow curves at 80 barg (1,160 psig) pressure .....15
5.2	CLP/CLP D-025-058 typical flow curves at 80 barg (1,160 psig) pressure .....16
5.3	CLP-055-080 typical flow curves at 80 barg (1,160 psig) pressure .....17
5.4	CLP/CLP D-085-152 typical flow curves at 80 barg (1,160 psig) pressure .....18
5.5	CLP/CLP D-140-500 typical flow curves at 80 barg (1,160 psig) pressure .....19
5.6	CLP D-580-1000 typical flow curves at 80 barg (1,160 psig) pressure .....20
5.7	CLP / CLP D-005-1000 typical NPIPr curves .....21
6.	Motor requirements .....24
7.	Installation .....24
7.1	Filtration .....25
7.2	Noise .....25
7.3	Preferred design .....25
8.	Service .....26
8.1	Spare parts .....26
8.2	Spare part suitcase .....26
9.	Dimensions and connections .....27
9.1	CLP / CLP D-005-017 pumps .....27
9.2	CLP / CLP D-025-058 pumps .....28
9.3	CLP / CLP D-025-058 pumps with spline .....29
9.4	CLP-055-080 pumps .....30
9.5	CLP / CLP D-085-152 pumps .....31
9.6	CLP / CLP D-140-500 pumps .....32
9.7	CLP D-580-1000 pumps .....33
10.	Pump and bell-housing .....34
11.	Pump base plate solution .....34

1. Introduction

CLP / CLP D pumps are specific designed for various chemicals, liquids, additives and other hard-to-handle fluids in production systems, placed in subsea, onshore and offshore applications.

Danfoss CLP pumps are based on the axial piston principle offering long life and high efficiency in the demanding oil and gas industry. The Danfoss CLP pumps have a light and compact design, resulting in one of the smallest footprints on the market.

All parts are designed to provide long service life, i.e. long service life with a constantly high efficiency and minimum of service required. Lubrication of the moving parts in the pumps is provided by the fluid itself. No oil lubrication is thus required.

The pumps are fixed displacement pumps in which the flow is proportional to the number of revolutions of the input shaft and the pump displacement, regardless of any counter-pressure.

The pump design ensures a minimal acceleration loss and low pulsation.

**If magnetic drive is required, please contact Danfoss High Pressure Pumps sales organization for further information.**

This datasheet covers CLP-005-500 and CLP D-005-1000 pumps. In the next pages all pumps will be named as CLP.

The CLP pumps are made in AISI 316, whereas the CLP D are made in Super Duplex / Duplex.

Below sectional drawing is a conceptual example of a CLP/CLP D-005-500 pump

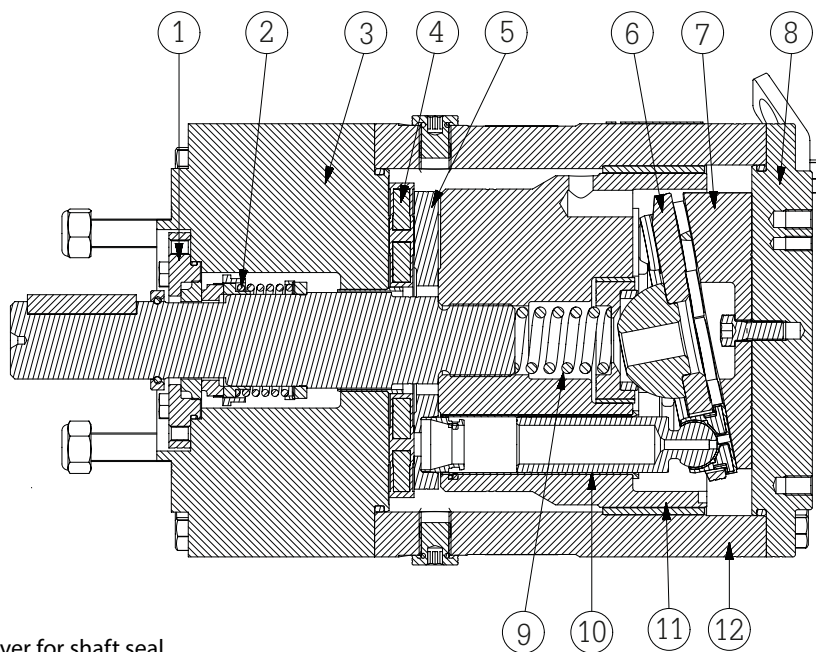

- 1: Cover for shaft seal
- 2: Shaft seal
- 3: Port flange
- 4: Port plate
- 5: Valve plate
- 6: Retainer plate
- 7: Swash plate
- 8: End flange
- 9: Spring
- 10: Piston
- 11: Cylinder barrel
- 12: Housing with bearing

Below sectional drawing is a conceptual example of a CLP D-580-1000 pump

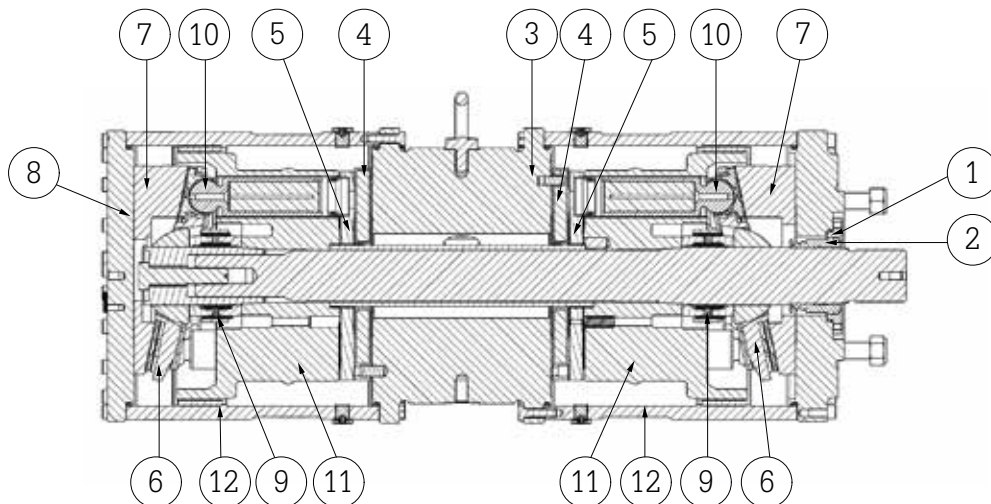

**2. Benefits**

- **High reliability:**
    - Constructed to provide maximum reliability.
    - Designed for a wide range of corrosive, volatile and other hard-to-handle fluids.
    - All parts are made of high-grade materials.
  - **Minimum service required:**
    - Generates insignificant pulsations in the discharge line.
    - No oil lubrication is required.
    - Long service life and easy maintenance.
  - **Low energy costs:**
    - The highly efficient axial piston design provides the lowest energy consumption of any comparable on the market.
  - **Zero risk of lubricant contamination:**
    - Oil lubricants are replaced with the pumped medium so there is no contamination risk from the pump.
  - **Easy installation:**
    - One of the smallest, lightest and most compact designs available in the market.
    - Pump can be installed horizontally or vertically except CLP 580-1000 which can be installed horizontally only.
    - In most cases no pulsation dampeners are necessary due to extremely low pulsations.
    - Powered by electric motors or combustion engines.
  - **Certified quality:**
    - ATEX available on request.
    - CE available.
    - Type approval available on request.
    - Design verification available on request.
- 

**3. Application examples**

- Dehydration / glycol pumping
- Transfer pumps
- Produced water injection
- Wash water system
- Chemical / technical processes
- Water make up pump
- Gas sweetening – “Amine”
- Water and glycol hydraulic fluid
- Subsea
- Closed and open drain pump
- Seal flush pump

**4. Technical data**
**4.1 CLP-005-017**

Pump size		CLP-005	CLP-008	CLP-010	CLP-015	CLP-017
Geometric displacement	cm <sup>3</sup> /rev	2	3,2	4,07	5,3	6,30
	in <sup>3</sup> /rev	0,12	0,20	0,25	0,32	0,38
<b>Pressure <sup>1)</sup></b>						
Min. continuous outlet pressure	barg	20	20	20	20	20
	psig	290	290	290	290	290
Max. continuous inlet pressure [MASP] <sup>2)</sup>	barg	5	5	5	5	5
	psig	73	73	73	73	73
Max. continuous outlet pressure [MAWP] <sup>6)</sup>	barg	198	198	198	198	187
	psig	2872	2872	2872	2872	2712
<b>Speed <sup>3)</sup></b>						
Min. speed <sup>7)</sup>	rpm	700	700	700	700	700
Max. speed <sup>5)</sup>	rpm	3600	3600	3600	3600	3600
<b>Typical flow 80 barg - Flow curves available in section 5</b>						
1500 rpm	l/min	2,70	4,32	5,50	7,45	8,86
3000 rpm	l/min	5,64	9,02	11,49	15,47	18,40
1800 rpm	gpm	0,87	1,39	1,76	2,38	2,83
3600 rpm	gpm	1,80	2,88	3,67	4,94	5,87
<b>Typical motor size 80 barg</b>						
1500 rpm	kW 50 Hz	0,75	1,1	1,1	1,5	2,2
1800 rpm	hp 60 Hz	0,75	1,5	1,5	3	3
3000 rpm	kW 50 Hz	1,1	1,5	2,2	3	3
3600 rpm	hp 60 Hz	1,5	3	3	5	5
<b>Technical specifications</b>						
Media temperature	°C	0 to 95	0 to 95	0 to 95	0 to 95	0 to 95
	°F	-17 to 203	-17 to 203	-17 to 203	-17 to 203	-17 to 203
Ambient temperature	°C	-45 to 60	-45 to 60	-45 to 60	-45 to 60	-45 to 60
	°F	-42 to 140	-42 to 140	-42 to 140	-42 to 140	-42 to 140
Sound pressure level <sup>4)</sup>	dB(A)	75	75	75	75	75
Weight	kg	6	6	6	6	6
	lbs	13	13	13	13	13

<sup>1)</sup> For lower and higher continuous pressure please contact Danfoss High Pressure Pumps.

<sup>2)</sup> NPIPr - see section 5.

<sup>3)</sup> For lower or higher continuous speed please contact Danfoss High Pressure Pumps.

<sup>4)</sup> According to ISO 3744 : 2010.

<sup>5)</sup> Over 3000 rpm, the pump operation is referred to as "High End Performance", max outlet pressure is limited to 140 bar and recommended inspection intervals are detailed in section 8.

<sup>6)</sup> Over 160 bar, the pump operation is referred to as "high end performance" and recommended inspection intervals are detailed in section 8.

<sup>7)</sup> Minimum speed is 1000 rpm when pumping DI water

4.2 CLP D-005-017

Pump size		CLP D-005	CLP D-008	CLP D-010	CLP D-015	CLP D-017
Geometric displacement	cm <sup>3</sup> /rev	2	3,2	4,07	5,3	6,30
	in <sup>3</sup> /rev	0,12	0,20	0,25	0,32	0,38
<b>Pressure <sup>1)</sup></b>						
Min. continuous outlet pressure	barg	20	20	20	20	20
	psig	290	290	290	290	290
Max. continuous inlet pressure [MASP] <sup>2)</sup>	barg	5	5	5	5	5
	psig	73	73	73	73	73
Max. continuous outlet pressure [MAWP] <sup>6)</sup>	barg	210	210	210	210	187
	psig	3045	3045	3045	3045	2712
<b>Speed <sup>3)</sup></b>						
Min. speed <sup>7)</sup>	rpm	700	700	700	700	700
Max. speed <sup>5)</sup>	rpm	3600	3600	3600	3600	3600
<b>Typical flow 80 barg - Flow curves available in section 5</b>						
1500 rpm	l/min	2,70	4,32	5,50	7,45	8,86
3000 rpm	l/min	5,64	9,02	11,49	15,47	18,40
1800 rpm	gpm	0,87	1,39	1,76	2,38	2,83
3600 rpm	gpm	1,80	2,88	3,67	4,94	5,87
<b>Typical motor size 80 barg</b>						
1500 rpm	kW 50 Hz	0,75	1,1	1,1	1,5	2,2
1800 rpm	hp 60 Hz	0,75	1,5	1,5	3	3
3000 rpm	kW 50 Hz	1,1	1,5	2,2	3	3
3600 rpm	hp 60 Hz	1,5	3	3	5	5
<b>Technical specifications</b>						
Media temperature	°C	0 to 95	0 to 95	0 to 95	0 to 95	0 to 95
	°F	-17 to 203	-17 to 203	-17 to 203	-17 to 203	-17 to 203
Ambient temperature	°C	-45 to 60	-45 to 60	-45 to 60	-45 to 60	-45 to 60
	°F	-42 to 140	-42 to 140	-42 to 140	-42 to 140	-42 to 140
Sound pressure level <sup>4)</sup>	dB(A)	75	75	75	75	75
Weight	kg	6	6	6	6	6
	lbs	13	13	13	13	13

<sup>1)</sup> For lower and higher continuous pressure please contact Danfoss High Pressure Pumps.

<sup>2)</sup> NPIP<sub>r</sub> - see section 5.

<sup>3)</sup> For lower or higher continuous speed please contact Danfoss High Pressure Pumps.

<sup>4)</sup> According to ISO 3744 : 2010.

<sup>5)</sup> Over 3000 rpm, the pump operation is referred to as "High End Performance", max outlet pressure is limited to 140 bar and recommended inspection intervals are detailed in section 8.

<sup>6)</sup> Over 160 bar, the pump operation is referred to as "high end performance" and recommended inspection intervals are detailed in section 8.

<sup>7)</sup> Minimum speed is 1000 rpm when pumping DI water

4.3 CLP-025-058

Pump size		CLP-025	CLP-035	CLP-042	CLP-050	CLP-058
Geometric displacement	cm <sup>3</sup> /rev	9,41	12,14	15,32	17,7	20,54
	in <sup>3</sup> /rev	0,57	0,74	0,93	1,08	1,25
<b>Pressure <sup>1)</sup></b>						
Min. continuous outlet pressure	barg	20	20	20	20	20
	psig	290	290	290	290	290
Max. continuous inlet pressure [MASP] <sup>2)</sup>	barg	5	5	5	5	5
	psig	73	73	73	73	73
Max. continuous outlet pressure [MAWP] <sup>6)</sup>	barg	201	201	201	201	188
	psig	2915	2915	2915	2915	2726
<b>Speed <sup>3)</sup></b>						
Min. speed	rpm	700	700	700	700	700
Max. speed <sup>5)</sup>	rpm	3600	3600	3600	3600	3600
<b>Typical flow 80 barg - Flow curves available in section 5</b>						
1500 rpm	l/min	12,00	16,09	20,86	24,43	28,69
3000 rpm	l/min	26,11	34,30	43,84	50,98	59,50
1800 rpm	gpm	3,91	5,21	6,73	7,86	9,21
3600 rpm	gpm	8,39	10,98	14,01	16,27	18,97
<b>Typical motor size 80 barg</b>						
1500 rpm	kW 50 Hz	3	3	4	5,5	5,5
1800 rpm	hp 60 Hz	5	5	7,5	7,5	10
3000 rpm	kW 50 Hz	5,5	7,5	7,5	11	11
3600 rpm	hp 60 Hz	7,5	10	15	15	20
<b>Technical specifications</b>						
Media temperature	°C	0 to 95	0 to 95	0 to 95	0 to 95	0 to 95
	°F	-17 to 203	-17 to 203	-17 to 203	-17 to 203	-17 to 203
Ambient temperature	°C	-45 to 60	-45 to 60	-45 to 60	-45 to 60	-45 to 60
	°F	-42 to 140	-42 to 140	-42 to 140	-42 to 140	-42 to 140
Sound pressure level <sup>4)</sup>	dB(A)	79	79	79	79	79
Weight	kg	9	9	9	9	9
	lbs	20	20	20	20	20

<sup>1)</sup> For lower and higher continuous pressure please contact Danfoss High Pressure Pumps.

<sup>2)</sup> NPIPr - see section 5.

<sup>3)</sup> For lower or higher continuous speed please contact Danfoss High Pressure Pumps.

<sup>4)</sup> According to ISO 3744 : 2010.

<sup>5)</sup> Over 3000 rpm, the pump operation is referred to as "High End Performance", max outlet pressure is limited to 140 bar and recommended inspection intervals are detailed in section 8.

<sup>6)</sup> Over 160 bar, the pump operation is referred to as "high end performance" and recommended inspection intervals are detailed in section 8.

4.4 CLP D-025-058

Pump size		CLP D-025	CLP D-035	CLP D-042	CLP D-050	CLP D-058
Geometric displacement	cm <sup>3</sup> /rev	9,41	12,14	15,32	17,7	20,54
	in <sup>3</sup> /rev	0,57	0,74	0,93	1,08	1,25
<b>Pressure <sup>1)</sup></b>						
Min. continuous outlet pressure	barg	20	20	20	20	20
	psig	290	290	290	290	290
Max. continuous inlet pressure [MASP] <sup>2) 7)</sup>	barg	5	5	5	5	5
	psig	73	73	73	73	73
Max. continuous outlet pressure [MAWP] <sup>6)</sup>	barg	210	210	210	204	188
	psig	3045	3045	3045	2958	2726
<b>Speed <sup>3)</sup></b>						
Min. speed	rpm	700	700	700	700	700
Max. speed <sup>5)</sup>	rpm	3600	3600	3600	3600	3600
<b>Typical flow 80 barg - Flow curves available in section 5</b>						
1500 rpm	l/min	12,00	16,09	20,86	24,43	28,69
3000 rpm	l/min	26,11	34,30	43,84	50,98	59,50
1800 rpm	gpm	3,91	5,21	6,73	7,86	9,21
3600 rpm	gpm	8,39	10,98	14,01	16,27	18,97
<b>Typical motor size 80 barg</b>						
1500 rpm	kW 50 Hz	3	3	4	5,5	5,5
1800 rpm	hp 60 Hz	5	5	7,5	7,5	10
3000 rpm	kW 50 Hz	5,5	7,5	7,5	11	11
3600 rpm	hp 60 Hz	7,5	10	15	15	20
<b>Technical specifications</b>						
Media temperature	°C	0 to 95	0 to 95	0 to 95	0 to 95	0 to 95
	°F	-17 to 203	-17 to 203	-17 to 203	-17 to 203	-17 to 203
Ambient temperature	°C	-45 to 60	-45 to 60	-45 to 60	-45 to 60	-45 to 60
	°F	-42 to 140	-42 to 140	-42 to 140	-42 to 140	-42 to 140
Sound pressure level <sup>4)</sup>	dB(A)	79	79	79	79	79
Weight	kg	9	9	9	9	9
	lbs	20	20	20	20	20

<sup>1)</sup> For lower and higher continuous pressure please contact Danfoss High Pressure Pumps.

<sup>2)</sup> NPIP - see section 5.

<sup>3)</sup> For lower or higher continuous speed please contact Danfoss High Pressure Pumps.

<sup>4)</sup> According to ISO 3744 : 2010.

<sup>5)</sup> Over 3000 rpm, the pump operation is referred to as "High End Performance", max outlet pressure is limited to 140 bar and recommended inspection intervals are detailed in section 8.

<sup>6)</sup> Over 160 bar, the pump operation is referred to as "high end performance" and recommended inspection intervals are detailed in section 8.

<sup>7)</sup> The max. continuous inlet pressure for the spline version is 10 barg



4.5 CLP-055-080

Pump size		CLP-055	CLP-072	CLP-080
Geometric displacement	cm <sup>3</sup> /rev	25	32	36
	in <sup>3</sup> /rev	1.53	1.95	2.2
<b>Pressure <sup>1)</sup></b>				
Min. continuous outlet pressure	barg	10	10	10
	psig	145	145	145
Max. continuous inlet pressure [MASP] <sup>2)</sup>	barg	10	10	10
	psig	145	145	145
Max. continuous outlet pressure [MAWP]	barg	160	160	160
	psig	2321	2321	2321
<b>Speed <sup>3)</sup></b>				
Min. speed	rpm	700	700	700
Max. speed	rpm	2400	2400	2400
<b>Typical flow 80 barg</b>				
1000 rpm	l/min	23.5	30.2	33.8
900 rpm	l/min	21.2	27.2	30.4
<b>Typical motor size 80 barg</b>				
1000 rpm	kW 50Hz	7.5	111	11
900 rpm	hp 60Hz	5.5	7.5	10
<b>Technical specifications</b>				
Media temperature	°C	0 to 95	0 to 95	0 to 95
	°F	-17 to 203	-17 to 203	-17 to 203
Ambient temperature	°C	-45 to 60	-45 to 60	-45 to 60
	°F	-42 to 140	-42 to 140	-42 to 140
Sound pressure level <sup>4)</sup>	dB(A)	79	79	79
Weight	kg	19	19	19
	lbs	42	42	42

<sup>1)</sup> For lower and higher continuous pressure please contact Danfoss High Pressure Pumps.

<sup>2)</sup> NPIPr - see section 5.

<sup>3)</sup> For lower or higher continuous speed please contact Danfoss High Pressure Pumps.

<sup>4)</sup> According to ISO 3744 : 2010.

4.6 CLP-085-152

Pump size		CLP-085	CLP-105	CLP-115	CLP-137	CLP-152
Geometric displacement	cm <sup>3</sup> /rev	50	63	70	80	90
	in <sup>3</sup> /rev	3.05	3.86	4.29	4.88	5.49
<b>Pressure <sup>1)</sup></b>						
Min. continuous outlet pressure	barg	10	10	10	10	10
	psig	145	145	145	145	145
Max. continuous inlet pressure [MASP] <sup>2)</sup>	barg	10	10	10	10	10
	psig	145	145	145	145	145
Max. continuous outlet pressure [MAWP]	barg	195	189	179	167	157
	psig	2828	2741	2596	2422	2277
<b>Speed <sup>3)</sup></b>						
Min. speed	rpm	700	700	700	700	700
Max. speed	rpm	1800	1800	1800	1800	1800
<b>Typical flow 80 barg</b>						
1000 rpm	l/min	46	58	65	75	84
1500 rpm	l/min	70	87	97	112	125
1200 rpm	gpm	15	18	21	24	27
1800 rpm	gpm	22	28	31	36	40
<b>Typical motor size 80 barg</b>						
1500 rpm	kW 50Hz	18.5	18.5	22	30	30
1800 rpm	hp 60Hz	21	21	25	25	35
<b>Technical specifications</b>						
Media temperature	°C	0 to 95	0 to 95	0 to 95	0 to 95	0 to 95
	°F	-17 to 203	-17 to 203	-17 to 203	-17 to 203	-17 to 203
Ambient temperature	°C	-45 to 60	-45 to 60	-45 to 60	-45 to 60	-45 to 60
	°F	-42 to 140	-42 to 140	-42 to 140	-42 to 140	-42 to 140
Sound pressure level <sup>4)</sup>	dB(A)	80	80	80	80	80
Weight	kg	40	40	40	40	40
	lbs	88	88	88	88	88

<sup>1)</sup> For lower and higher continuous pressure please contact Danfoss High Pressure Pumps.

<sup>2)</sup> NPIPr - see section 5.

<sup>3)</sup> For lower or higher continuous speed please contact Danfoss High Pressure Pumps.

<sup>4)</sup> According to ISO 3744 : 2010.

4.7 CLP D-085-152

Pump size		CLP D-085	CLP D-105	CLP D-115	CLP D-137	CLP D-152
Geometric displacement	cm <sup>3</sup> /rev	50	63	70	80	90
	in <sup>3</sup> /rev	3.05	3.86	4.29	4.88	5.49
<b>Pressure <sup>1)</sup></b>						
Min. continuous outlet pressure	barg	10	10	10	10	10
	psig	145	145	145	145	145
Max. continuous inlet pressure [MASP] <sup>2)</sup>	barg	10	10	10	10	10
	psig	145	145	145	145	145
Max. continuous outlet pressure [MAWP]	barg	211	189	179	167	157
	psig	3060	2741	2596	2422	2277
<b>Speed <sup>3)</sup></b>						
Min. speed	rpm	700	700	700	700	700
Max. speed	rpm	1800	1800	1800	1800	1800
<b>Typical flow 80 barg</b>						
1000 rpm	l/min	46	58	65	75	84
1500 rpm	l/min	70	87	97	112	125
1200 rpm	gpm	15	18	21	24	27
1800 rpm	gpm	22	28	31	36	40
<b>Typical motor size 80 barg</b>						
1500 rpm	kW 50Hz	18.5	18.5	22	30	30
1800 rpm	hp 60Hz	21	21	25	25	35
<b>Technical specifications</b>						
Media temperature	°C	0 to 95	0 to 95	0 to 95	0 to 95	0 to 95
	°F	-17 to 203	-17 to 203	-17 to 203	-17 to 203	-17 to 203
Ambient temperature	°C	-45 to 60	-45 to 60	-45 to 60	-45 to 60	-45 to 60
	°F	-42 to 140	-42 to 140	-42 to 140	-42 to 140	-42 to 140
Sound pressure level <sup>4)</sup>	dB(A)	80	80	80	80	80
Weight	kg	40	40	40	40	40
	lbs	88	88	88	88	88

<sup>1)</sup> For lower and higher continuous pressure please contact Danfoss High Pressure Pumps.

<sup>2)</sup> NPIPr - see section 5.

<sup>3)</sup> For lower or higher continuous speed please contact Danfoss High Pressure Pumps.

<sup>4)</sup> According to ISO 3744 : 2010.

**4.8 CLP-140-500**

Pump size		CLP-140	CLP-185	CLP-230	CLP-290	CLP-320	CLP-350	CLP-400	CLP-440	CLP-500
Geometric displacement	cm <sup>3</sup> /rev	127	165,4	204	256	282	308	362	389	444
	in <sup>3</sup> /rev	7,75	10,09	12,45	15,62	17,21	18,8	22,09	23,74	27,1
<b>Pressure <sup>1)</sup></b>										
Min. continuous outlet pressure	barg	10	10	10	10	10	10	10	10	10
	psig	145	145	145	145	145	145	145	145	145
Max. continuous inlet pressure [MASP] <sup>2)</sup>	barg	10	10	10	10	10	10	10	10	10
	psig	145	145	145	145	145	145	145	145	145
Max. continuous outlet pressure [MAWP] <sup>6)</sup>	barg	199	199	199	199	190	184	171	165	155
	psig	2886	2886	2886	2886	2755	2668	2480	2393	2248
<b>Speed <sup>3)</sup></b>										
Min. speed	rpm	700	700	700	700	700	700	700	700	700
Max. speed <sup>5)</sup>	rpm	1500	1500	1500	1500	1500	1500	1500	1500	1500
<b>Typical flow 80 barg</b>										
1000 rpm	l/min	107	145	184	236	262	292	348	370	428
900 rpm	l/min	25	34	43	56	62	69	82	88	101
<b>Typical motor size 80 barg</b>										
1000 rpm	kW 50Hz	22	30	37	45	45	55	75	75	75
900 rpm	hp 60Hz	25	30	40	57	57	70	70	85	85
<b>Technical specifications</b>										
Media temperature	°C	0 to 95	0 to 95	0 to 95	0 to 95	0 to 95	0 to 95	0 to 95	0 to 95	0 to 95
	°F	-17 to 203	-17 to 203	-17 to 203	-17 to 203	-17 to 203	-17 to 203	-17 to 203	-17 to 203	-17 to 203
Ambient temperature	°C	-45 to 60	-45 to 60	-45 to 60	-45 to 60	-45 to 60	-45 to 60	-45 to 60	-45 to 60	-45 to 60
	°F	-42 to 140	-42 to 140	-42 to 140	-42 to 140	-42 to 140	-42 to 140	-42 to 140	-42 to 140	-42 to 140
Sound pressure level <sup>4)</sup>	dB(A)	85	85	85	85	85	85	85	85	85
Weight	kg	110	110	110	110	110	110	110	110	110
	lbs	242	242	242	242	242	242	242	242	242

<sup>1)</sup> For lower and higher continuous pressure please contact Danfoss High Pressure Pumps.

<sup>2)</sup> NPIPr - see section 5.

<sup>3)</sup> For lower or higher continuous speed please contact Danfoss High Pressure Pumps.

<sup>4)</sup> According to ISO 3744 : 2010.

<sup>5)</sup> Over 3000 rpm, the pump operation is referred to as "High End Performance", max outlet pressure is limited to 140 bar and recommended inspection intervals are detailed in section 8.

<sup>6)</sup> Over 160 bar, the pump operation is referred to as "high end performance" and recommended inspection intervals are detailed in section 8.

**4.9 CLP D-140-500**

Pump size		CLP D-140	CLP D-185	CLP D-230	CLP D-290	CLP D-320	CLP D-350	CLP D-400	CLP D-440	CLP D-500
Geometric displacement	cm <sup>3</sup> /rev	127	165,4	204	256	282	308	362	389	444
	in <sup>3</sup> /rev	7,75	10,09	12,45	15,62	17,21	18,8	22,09	23,74	27,1
<b>Pressure <sup>1)</sup></b>										
Min. continuous outlet pressure	barg	10	10	10	10	10	10	10	10	10
	psig	145	145	145	145	145	145	145	145	145
Max. continuous inlet pressure [MASP] <sup>2)</sup>	barg	10	10	10	10	10	10	10	10	10
	psig	145	145	145	145	145	145	145	145	145
Max. continuous outlet pressure [MAWP] <sup>6)</sup>	barg	211	211	211	211	190	184	171	165	155
	psig	3060	3060	3060	3060	2755	2668	2480	2393	2248
<b>Speed <sup>3)</sup></b>										
Min. speed	rpm	700	700	700	700	700	700	700	700	700
Max. speed <sup>5)</sup>	rpm	1500	1500	1500	1500	1500	1500	1500	1500	1500
<b>Typical flow 80 barg</b>										
1000 rpm	l/min	107	145	184	236	262	292	348	370	428
900 rpm	l/min	25	34	43	56	62	69	82	88	101
<b>Typical motor size 80 barg</b>										
1000 rpm	kW 50Hz	22	30	37	45	45	55	75	75	75
900 rpm	hp 60Hz	25	30	40	57	57	70	70	85	85
<b>Technical specifications</b>										
Media temperature	°C	0 to 95	0 to 95	0 to 95	0 to 95	0 to 95	0 to 95	0 to 95	0 to 95	0 to 95
	°F	-17 to 203	-17 to 203	-17 to 203	-17 to 203	-17 to 203	-17 to 203	-17 to 203	-17 to 203	-17 to 203
Ambient temperature	°C	-45 to 60	-45 to 60	-45 to 60	-45 to 60	-45 to 60	-45 to 60	-45 to 60	-45 to 60	-45 to 60
	°F	-42 to 140	-42 to 140	-42 to 140	-42 to 140	-42 to 140	-42 to 140	-42 to 140	-42 to 140	-42 to 140
Sound pressure level <sup>4)</sup>	dB(A)	85	85	85	85	85	85	85	85	85
Weight	kg	110	110	110	110	110	110	110	110	110
	lbs	242	242	242	242	242	242	242	242	242

<sup>1)</sup> For lower and higher continuous pressure please contact Danfoss High Pressure Pumps.

<sup>2)</sup> NPIPr - see section 5.

<sup>3)</sup> For lower or higher continuous speed please contact Danfoss High Pressure Pumps.

<sup>4)</sup> According to ISO 3744 : 2010.

<sup>5)</sup> Over 3000 rpm, the pump operation is referred to as "High End Performance", max outlet pressure is limited to 140 bar and recommended inspection intervals are detailed in section 8.

<sup>6)</sup> Over 160 bar, the pump operation is referred to as "high end performance" and recommended inspection intervals are detailed in section 8.

4.10 CLP D-580-1000

Pump size		CLP D-580	CLP D-640	CLP D-700	CLP D-800	CLP D-880	CLP D-1000
Geometric displacement	cm <sup>3</sup> /rev	512	564	616	724	778	888
	in <sup>3</sup> /rev	31.24	34.42	37.59	44.18	47.48	54.19
<b>Pressure <sup>1)</sup></b>							
Min. continuous outlet pressure	barg	10	10	10	10	10	10
	psig	145	145	145	145	145	145
Max. continuous inlet pressure [MASP] <sup>2)</sup>	barg	10	10	10	10	10	10
	psig	145	145	145	145	145	145
Max. continuous outlet pressure [MAWP]	barg	120	120	120	120	120	120
	psig	1740	1740	1740	1740	1740	1740
<b>Speed <sup>3)</sup></b>							
Min. speed	rpm	700	700	700	700	700	700
Max. speed	rpm	1200	1200	1200	1200	1200	1200
<b>Typical flow 80 barg</b>							
1000 rpm	l/min	485	536	585	689	739	844
900 rpm	l/min	438	482	527	619	665	759
<b>Typical motor size 80 barg</b>							
1000 rpm	kW 50Hz	75	90	110	132	132	132
900 rpm	hp 60Hz	100	100	125	150	150	175
<b>Technical specifications</b>							
Media temperature	°C	0 to 95	0 to 95	0 to 95	0 to 95	0 to 95	0 to 95
	°F	-17 to 203	-17 to 203	-17 to 203	-17 to 203	-17 to 203	-17 to 203
Ambient temperature	°C	-45 to 60	-45 to 60	-45 to 60	-45 to 60	-45 to 60	-45 to 60
	°F	-42 to 140	-42 to 140	-42 to 140	-42 to 140	-42 to 140	-42 to 140
Sound pressure level <sup>4)</sup>	dB(A)	85	85	85	85	85	85
Weight	kg	227	227	227	227	227	227
	lbs	500	500	500	500	500	500

<sup>1)</sup> For lower and higher continuous pressure please contact Danfoss High Pressure Pumps.

<sup>2)</sup> NPIPr - see section 5.

<sup>3)</sup> For lower or higher continuous speed please contact Danfoss High Pressure Pumps.

<sup>4)</sup> According to ISO 3744 : 2010.

5. Pressure and flow

5.1 CLP/CLP D-005-017 typical flow curves at 80 barg (1,160 psig) pressure

The curves below show that the flow can be changed by changing the speed of the pump. The flow/rpm ratio is constant, and the 'desired'

flow can be obtained by changing the speed to a corresponding value. Thus, the required rpm can be determined as:

$$\text{Required rpm} = \frac{\text{Desired flow} \times \text{Rated rpm}}{\text{Rated flow}}$$

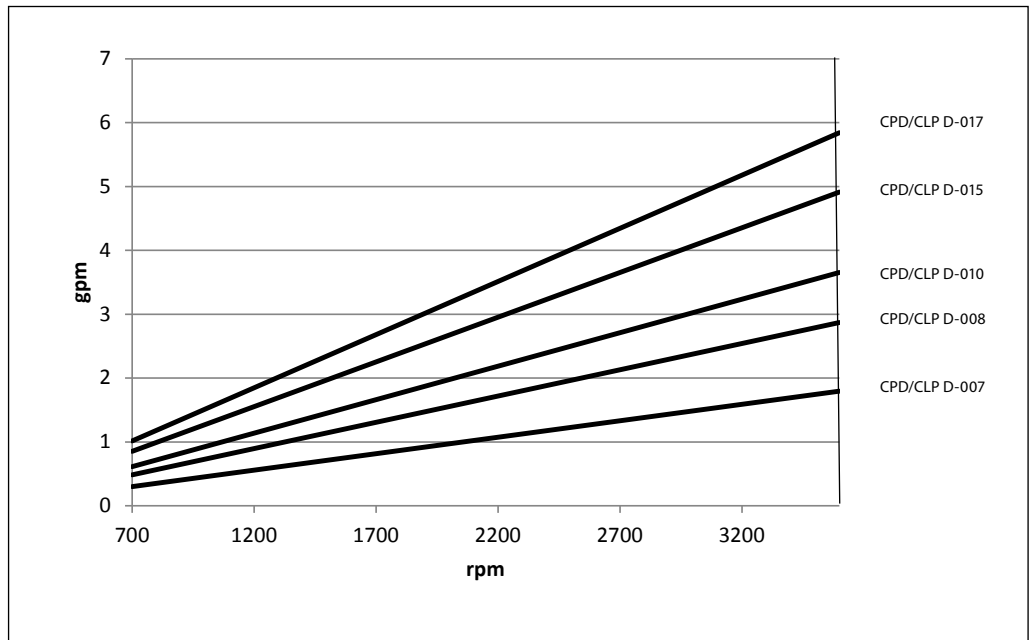
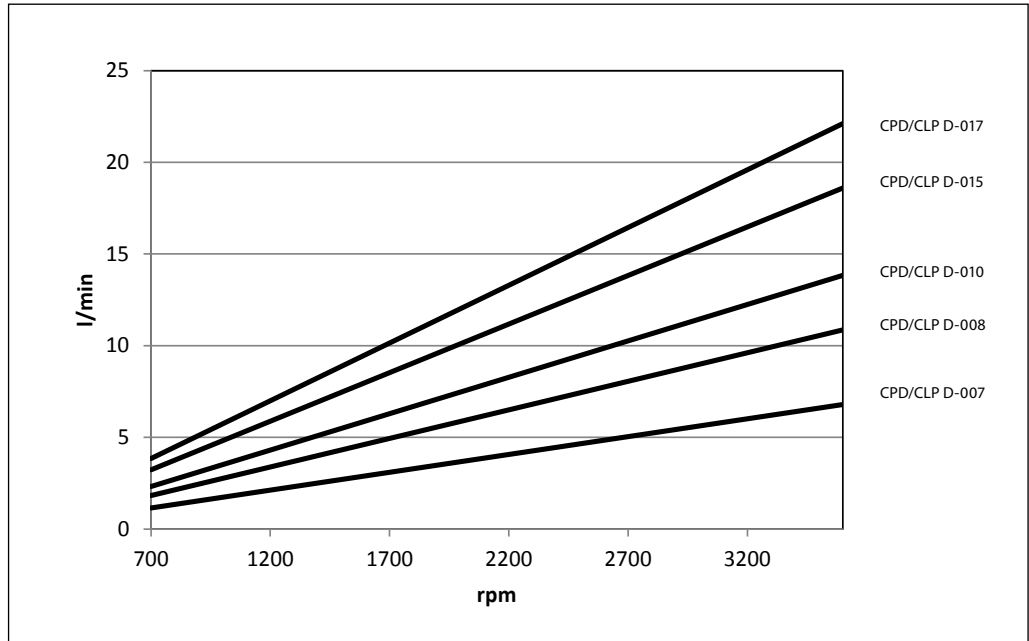

5.2 CLP/CLP D-025-058 typical flow curves at 80 barg (1,160 psig) pressure

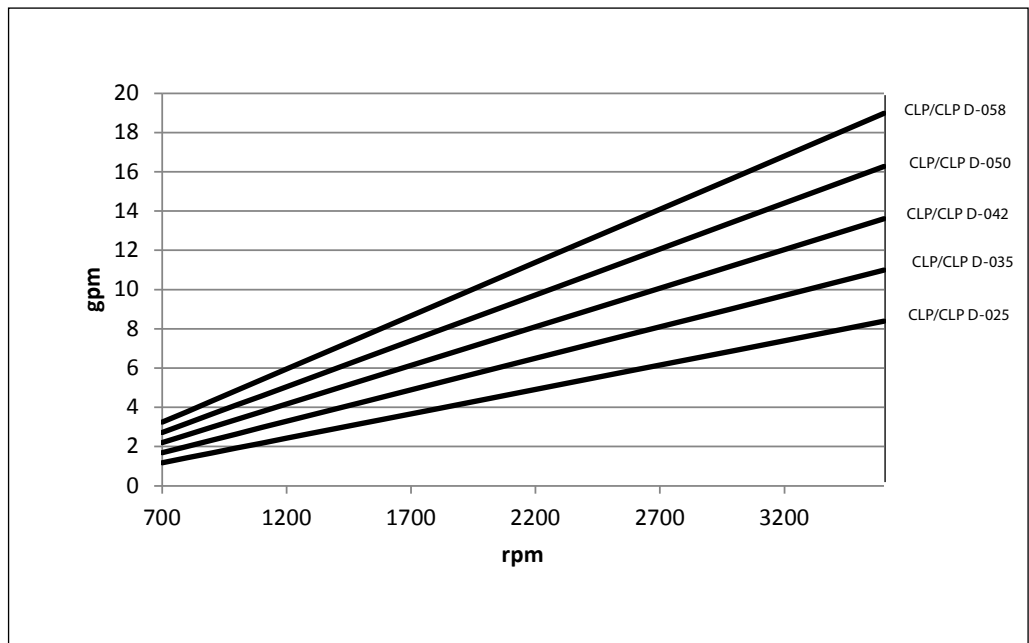
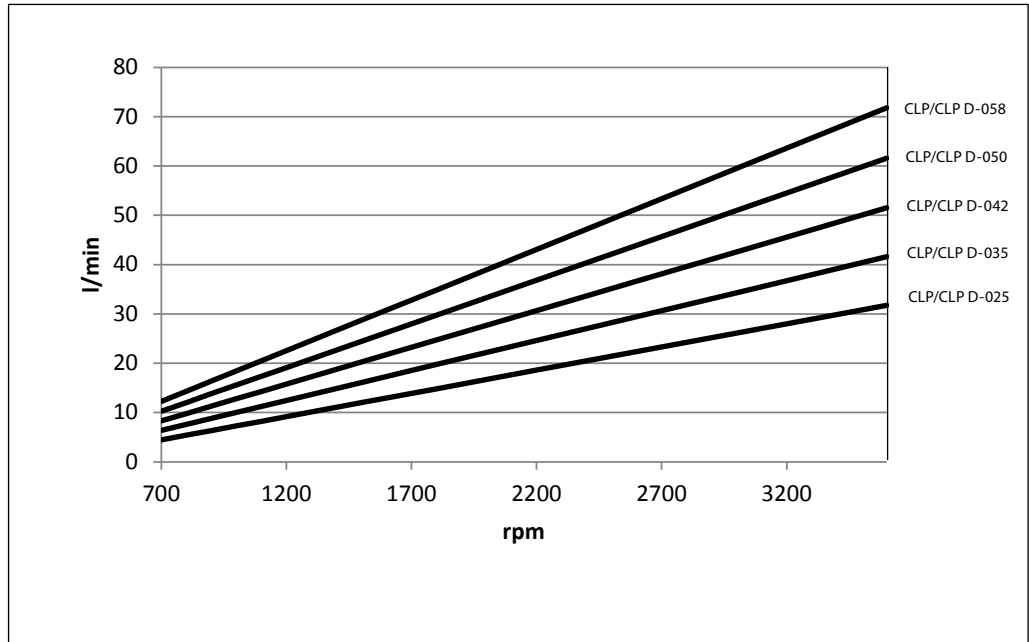



5.3 CLP-055-080 typical flow curves at 80 barg (1,160 psig) pressure

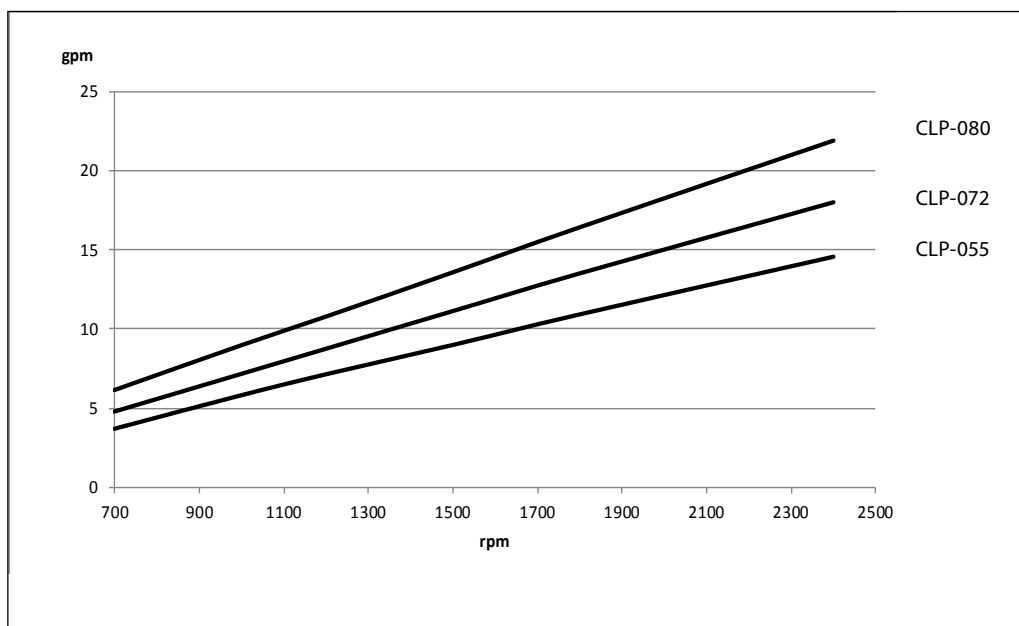
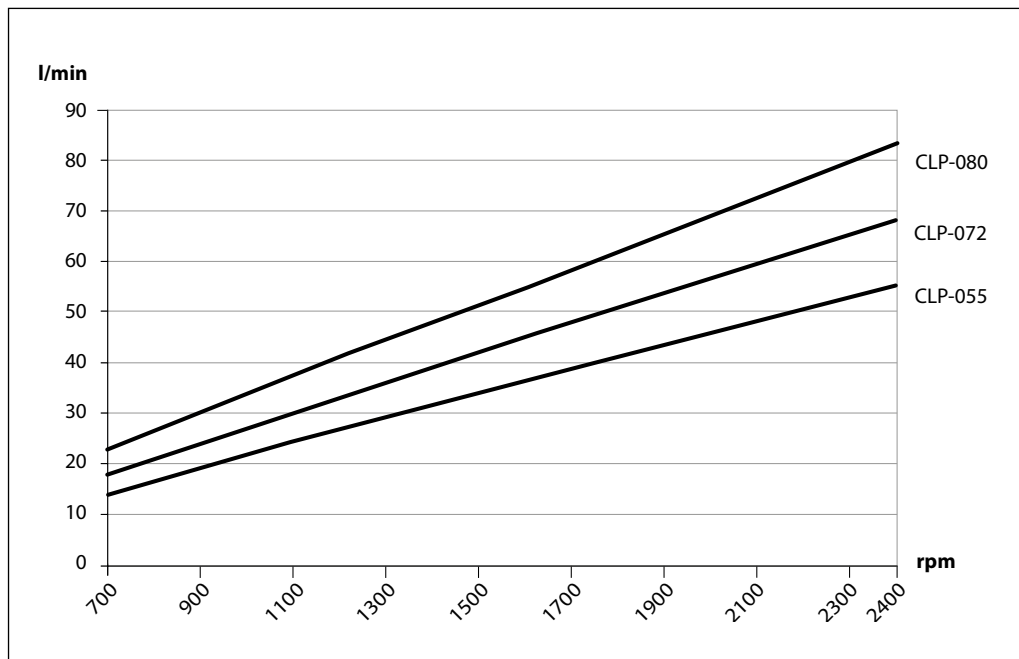

5.4 CLP/CLP D-085-152 typical flow curves at 80 barg (1,160 psig) pressure

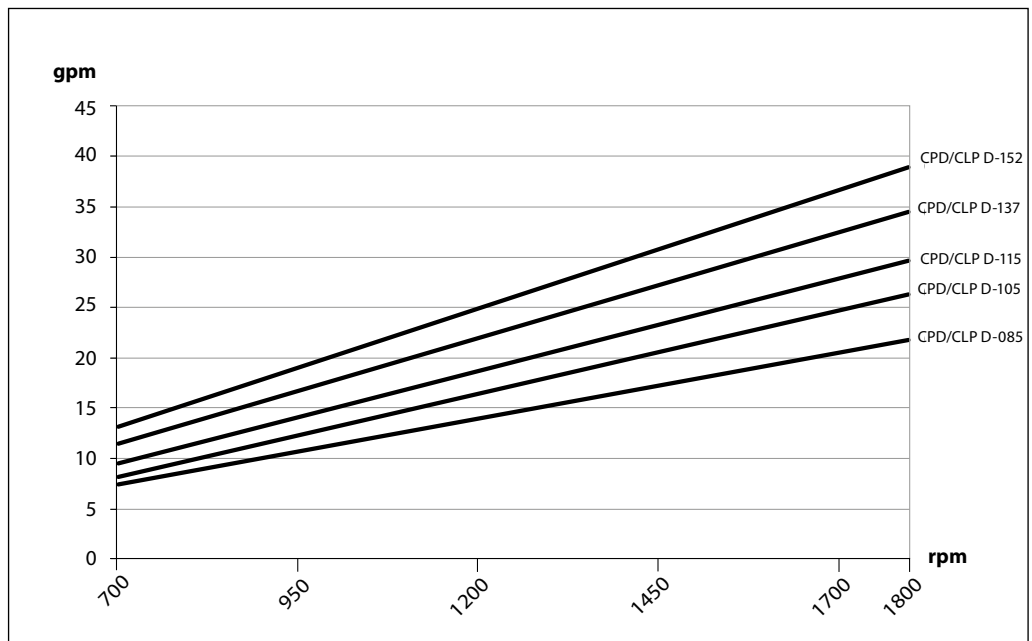
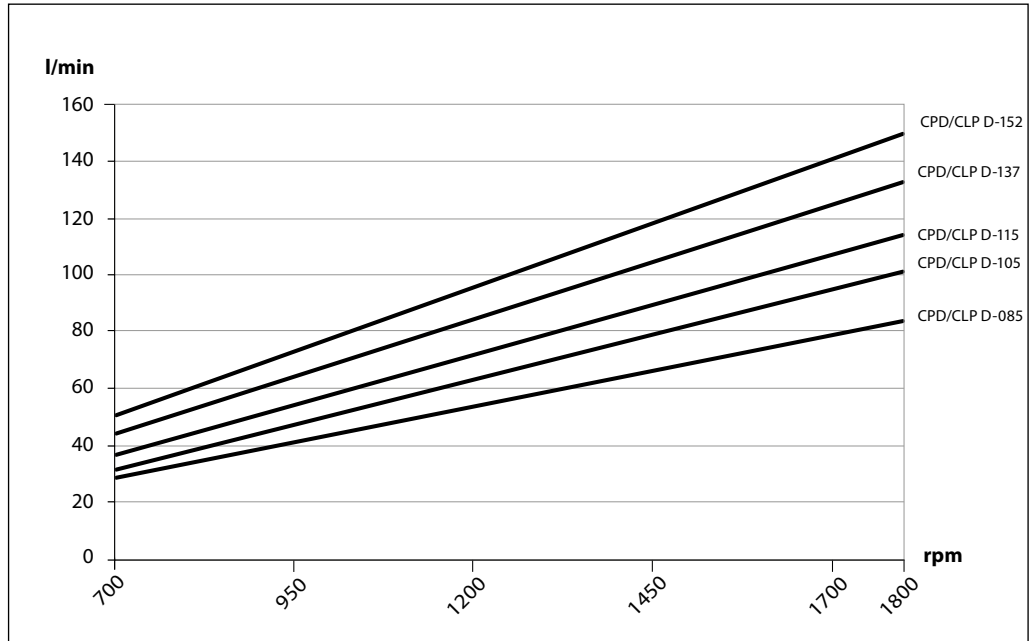

5.5 CLP/CLP D-140-500 typical flow curves at 80 barg (1,160 psig) pressure

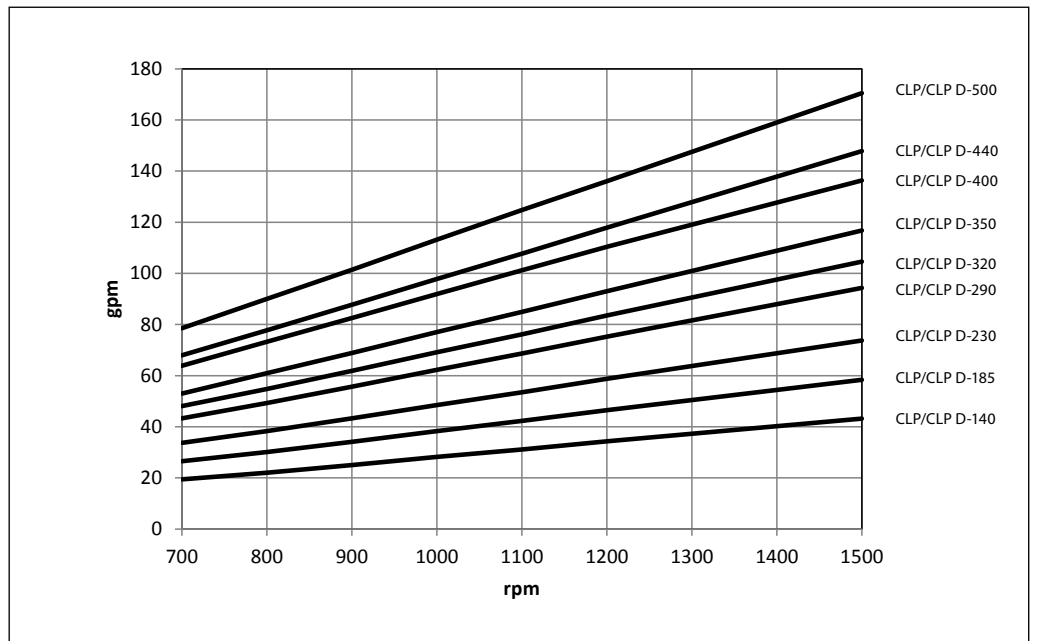
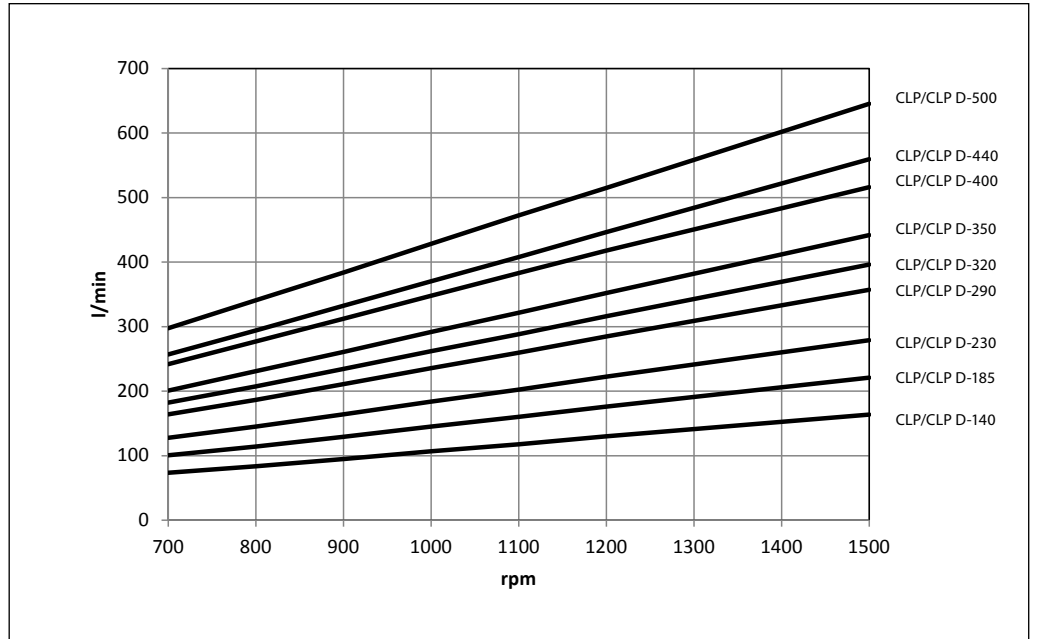

5.6 CLP D-580-1000 typical flow curves at 80 barg (1,160 psig) pressure

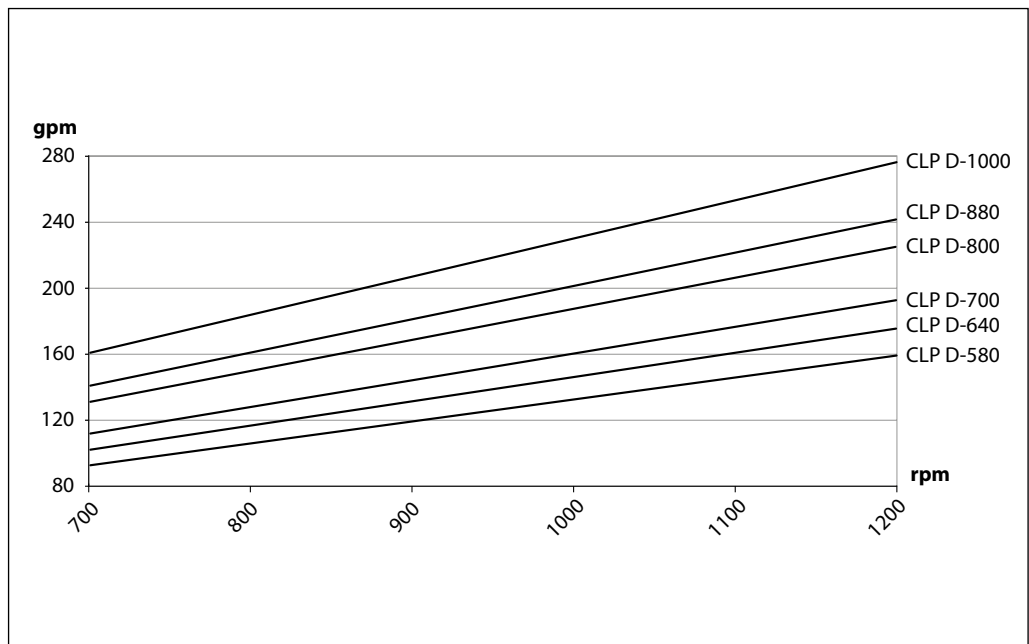
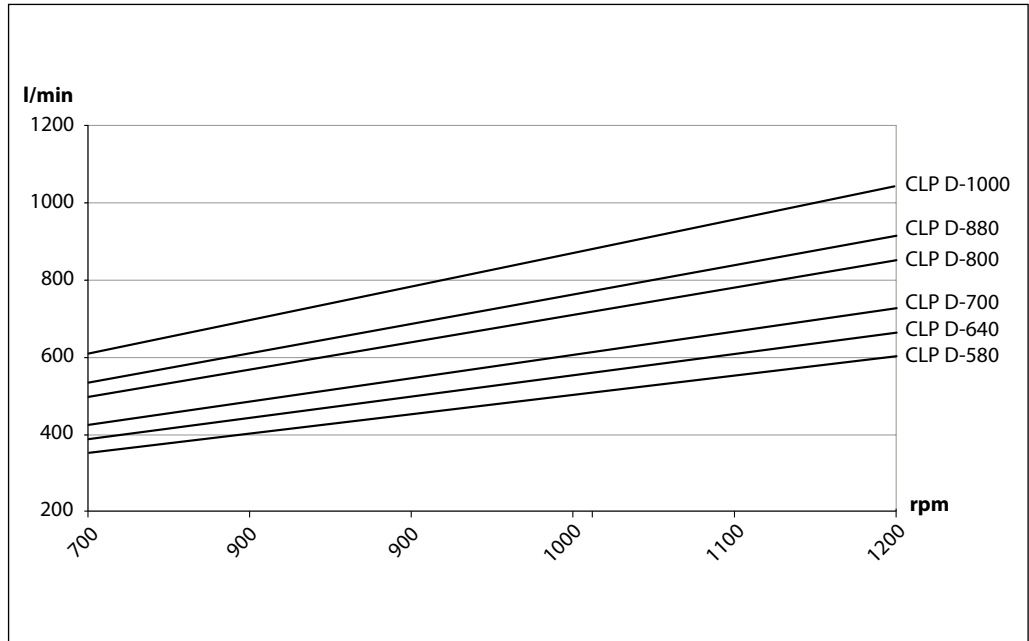

**5.7 CLP / CLP D-005-1000 typical NPIPr curves**

NPIPr depends on the speed of the CLP pump.  
The curves are based on water.

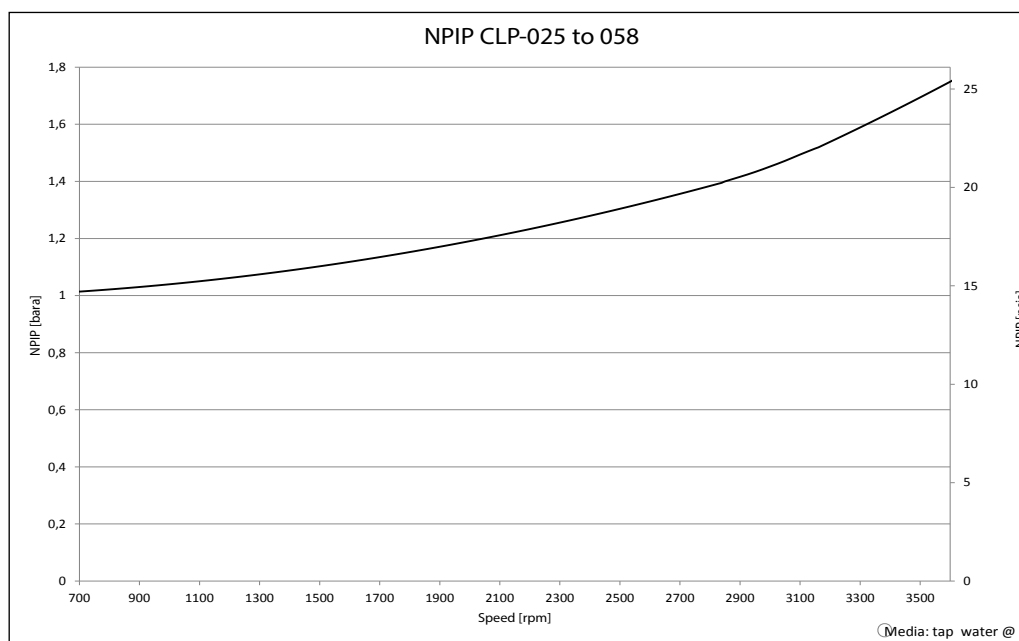
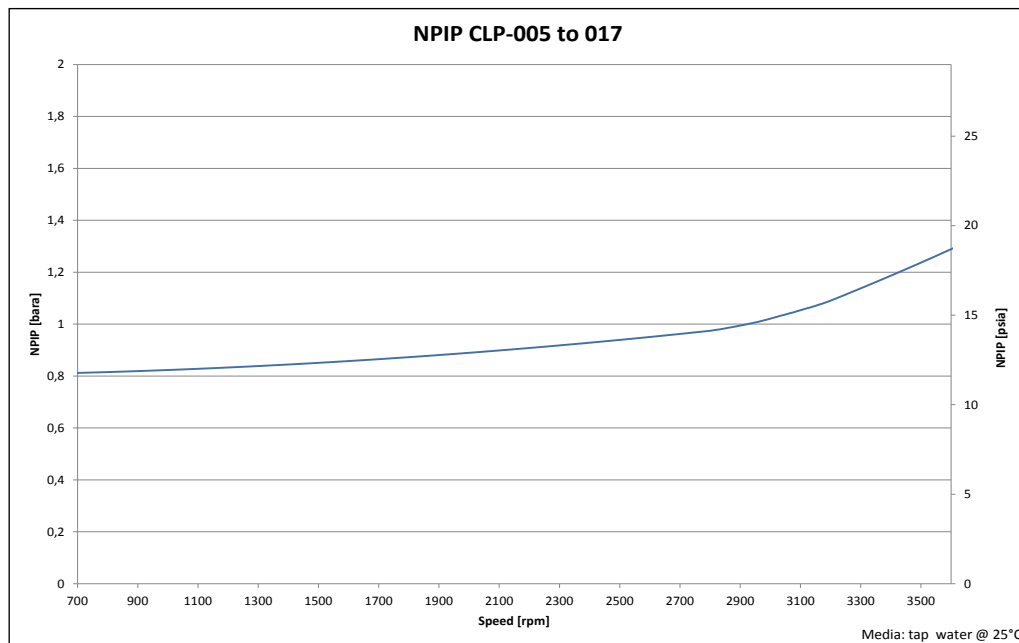

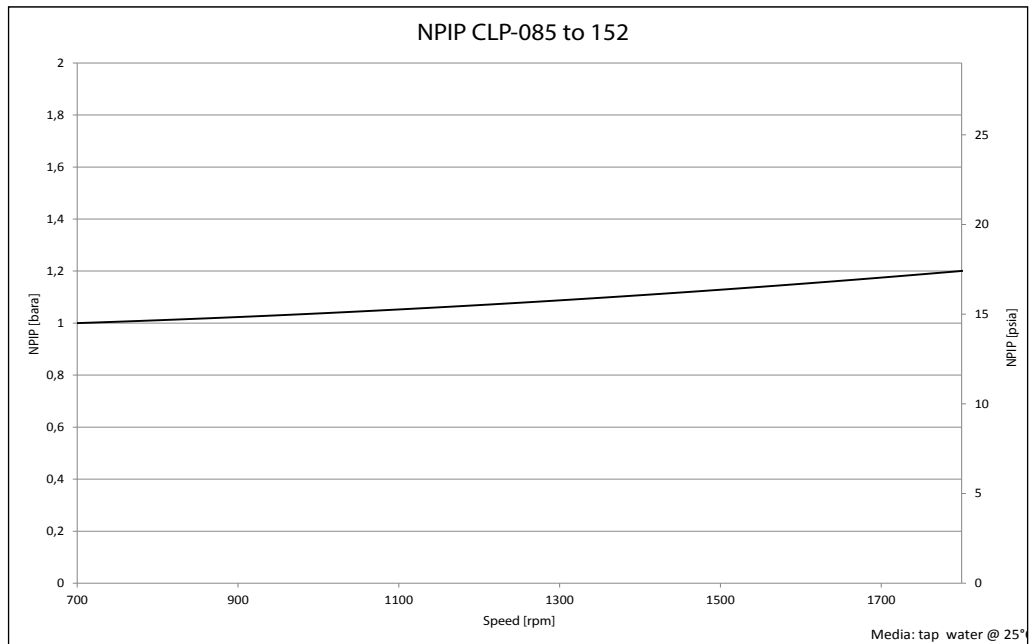
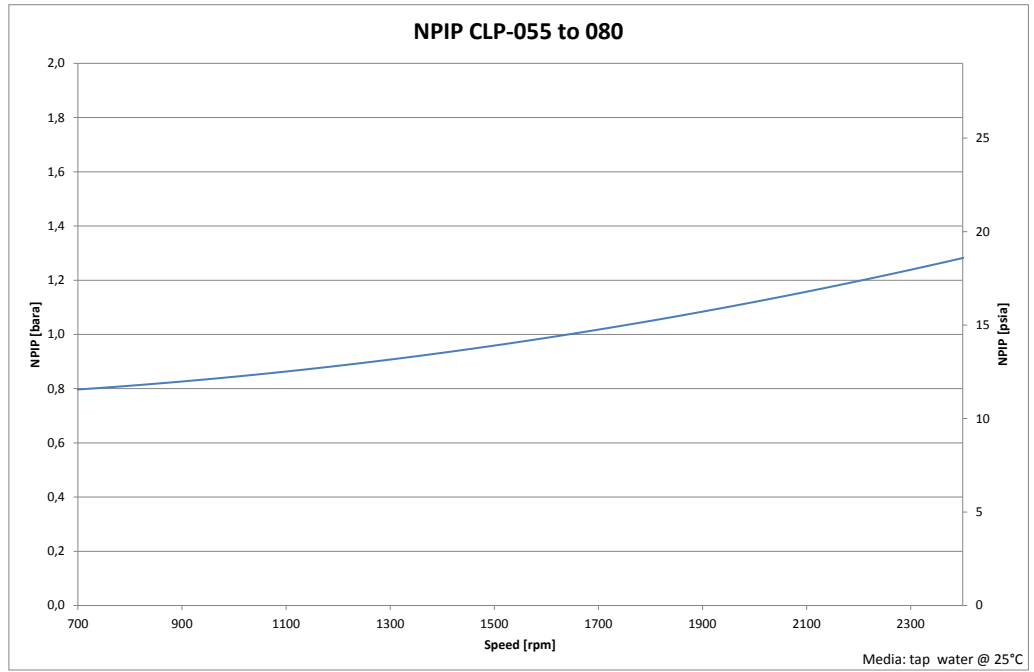

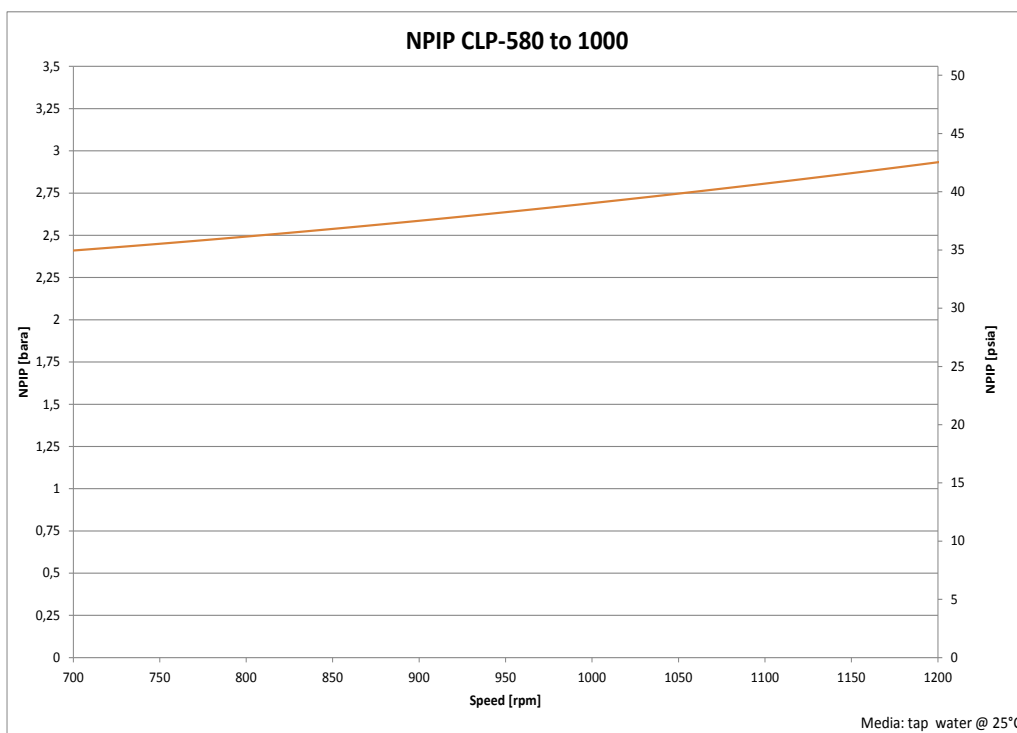
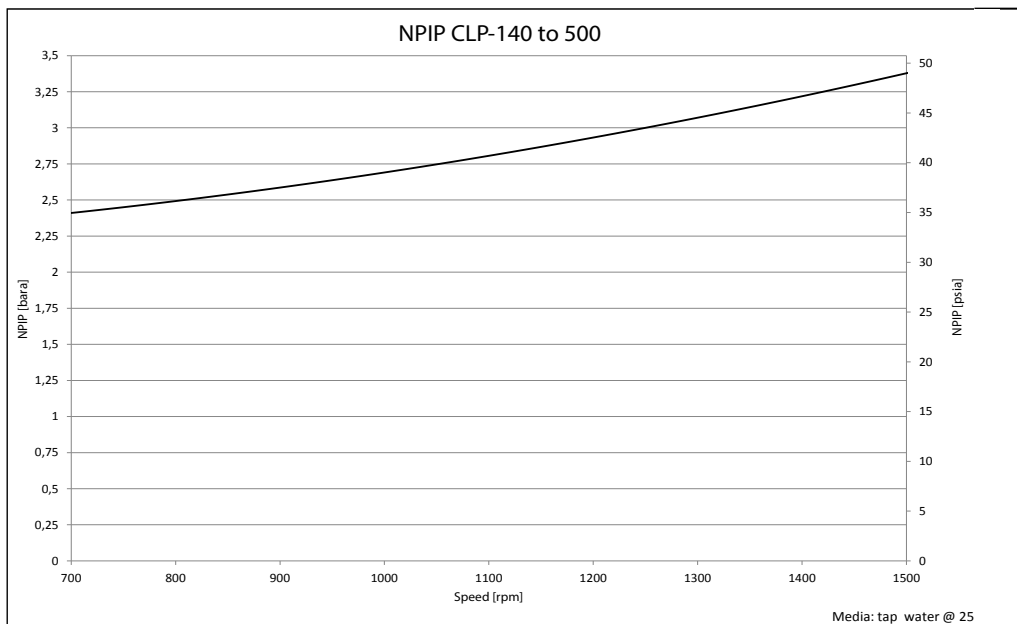

**6. Motor requirements**

The required motor power can be calculated by using the following equation:

$$P = \frac{n \times V \times p}{600.000 \times \eta}$$

- P: Power (kW)
- M: Torque (Nm)
- $\eta$ : Mechanical efficiency
- p: Pressure (barg)
- n: Motor speed (rpm)
- V: Displacement (cm<sup>3</sup>/rev.)

From the flow curves in section 5, you can determine the rpm of the pump at the desired flow.

The required torque is calculated as follows:

$$M = \frac{V \times p}{62.8 \times \eta}$$

To determine the correct motor size, both the power and torque requirement must be verified.

Indication of the mechanical efficiency of the pump at 80 barg (1,160 psig)

CLP / CLP D-005-017 @ 3000 rpm	0.86
CLP / CLP D-025-058 @ 3000 rpm	0.92
CLP-055-080 @ 2400 rpm	0.97
CLP / CLP D-085-152 @ 1800 rpm	0.91
CLP / CCLP D-140-500 @ 1200 rpm	0.92
CLP D-580-1000 @ 1200 rpm	0.90

**7. Installation**

The figure below illustrates how to mount the pump and connect it to electric motor/combustion engine.

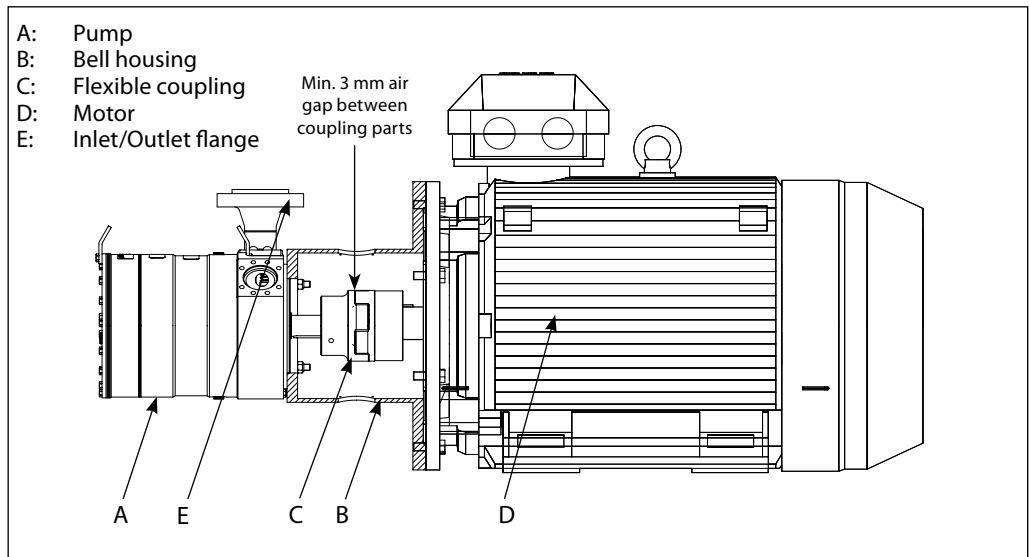



### 7.1 Filtration

As many chemicals have very low viscosity, the CLP pumps have been designed with very narrow clearance in order to control internal leakage rates and improve component performance. Therefore it is important that the inlet liquid is filtered properly to minimize the wear of the pump.

The main filter must have a filtration efficiency of 99.98% at 10 µm. We recommend that you use precision depth filter cartridges rated 10 µm abs.  $\beta_{10} \geq 5000$  (equivalent to a filtration efficiency of 99.98%). Bag filters and string wound filter cartridges typically have only 90% filtration efficiency. This means that for each 100,000 particles reaching the filter, 10,000 particles pass through it compared to only 20 particles in a filter with an efficiency of 99.98%.

For more information on the importance of proper filtration, please consult our publication "Filtration" (code number 521B1009), which also will provide you with an explanation of filtration definitions and a guidance on how to select the right filter.

### 7.2 Noise

Since the pump unit is mounted on a frame, the overall noise level can only be determined for a complete system. To minimize vibrations and noise throughout the system, it is therefore very important to mount the pump unit correctly on a frame with dampeners and to use flexible hoses rather than metal pipes where possible.

The noise level is influenced by:

- **Pump speed:** High rpm makes more fluid/structure-borne pulsations/vibrations than low rpm.
- **Discharge pressure:** High pressures make more noise than low pressures.
- **Pump mounting:** Rigid mounting makes more noise than flexible mounting because of the structure-borne vibrations. Be sure to use dampeners when mounting.
- **Connections to pump:** Pipes connected directly to the pump make more noise than flexible hoses because of structure-borne vibrations.
- **Variable frequency drives (VFDs):** Motors regulated by VFDs can produce more noise if the VFD does not have the right settings.

### 7.3 Preferred design

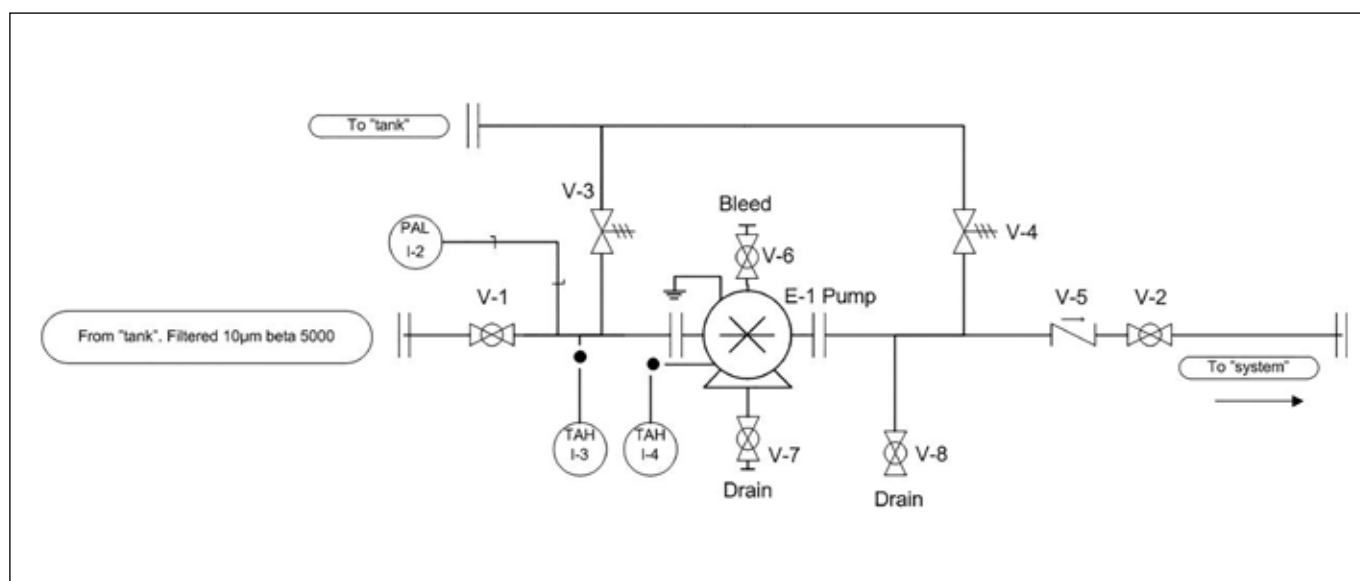

#### Purpose of valve "V-1" and "V-2":

Isolation valves, which make it possible to drain the pump before servicing.

#### Purpose of valve "V-3"

Safety/relief valve, this valve must protect the pump against too high inlet pressure. Too high inlet pressure can be caused by:

- The pump is rotating in the wrong direction.
- A situation where valve V-1 is closed, valve V-2 is open and V-5 is leaking.

#### Purpose of valve "V-4":

Safety/relief valve, this valve must protect the pump against too high outlet pressure. Too high outlet pressure can be caused by:

- A situation where V-2 is closed.
- Check valve V-5 has been mounted in the wrong direction.

The V-4 setting has to be 10% above the maximum system pressure. The electric motor must be designed for this pressure.

**Purpose of "V-5":**

Check valve, this valve prevents the flow from running reverse into the pump when connected to a multipump system.

**Purpose of "V-6":**

Bleed valve, this valve removes air from the pump and pipes.

**Purpose of "V-7" and "V-8":**

Drain valves, those valves help to empty the pump and pipes for fluid prior to service.

**Purpose of "PAL":**

Pressure alarm low, this projects the pump from running dry.

**Purpose of "TAH 1-3":**

Temperature alarm high, this protects the pump from too high inlet media temperature.

**Purpose of "TAH 1-4":**

Temperature alarm high, this protects the pump from running hot due to over pressure or the pump running dry.

**8. Service**

Danfoss CLP pumps are designed for long periods of service-free operation to ensure low maintenance and life cycle costs. Provided that the pump is installed and operated according to Danfoss specifications, Danfoss CLP pumps typically run 1 year between service. However, the service schedule for your Danfoss CLP pump may vary according to the application and other factors.

The life of a pump may be greatly shortened if Danfoss recommendations concerning system design and operation are not followed.

**In our experience, poor filtration is the number one cause of pump damage.**

Other factors that affect pump performance and lifetime include:

- running the pump at speeds outside specifications.
- supplying the pump with water at temperatures higher than recommended.
- running the pump at inlet pressures outside specifications.
- running the pump at outlet pressures outside the specifications.

We recommend that you inspect your pump after 1 year of operation even if it is running without any noticeable problems. Replace any worn parts if necessary, including pistons and shaft seals, to keep your pump running efficiently and to prevent breakdown. If worn parts are not replaced, then our guidelines recommend more frequent inspection.

If your pump is running continuously under "high end performance" conditions we recommend that you inspect your pump after half a year of operation, replacing worn parts if necessary.

**8.1 Spare parts**

The following spare parts kits are available for the CLP pumps.

Seal and screw set
Shaft seal set
Cylinder barrel
Valve plate set
Retainer set
Piston set

**8.2 Spare part suitcase**

Danfoss High Pressure Pumps can provide a spare part suitcase containing all necessary parts and instructions for overhaul of CLP pumps.

The suitcase can at any time be returned for refill of consumed parts.

Contact Danfoss High Pressure Pumps for price and availability of the spare part suitcase.

9. Dimensions and connections

9.1 CLP / CLP D-005-017 pumps

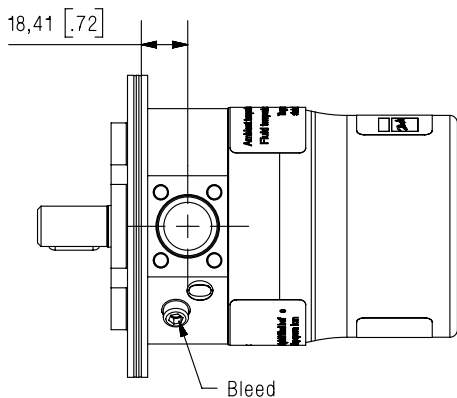
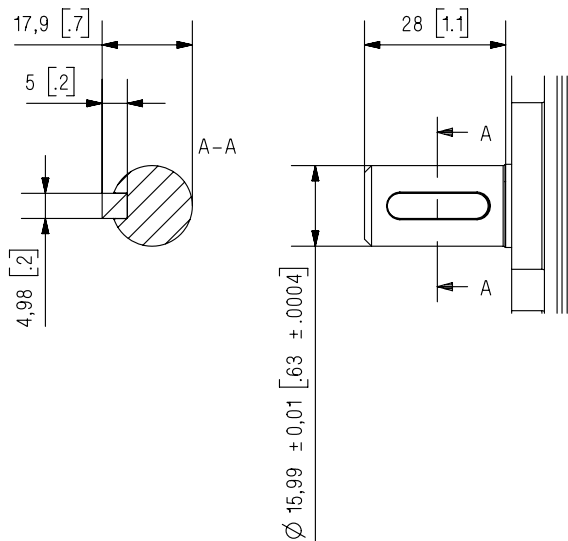
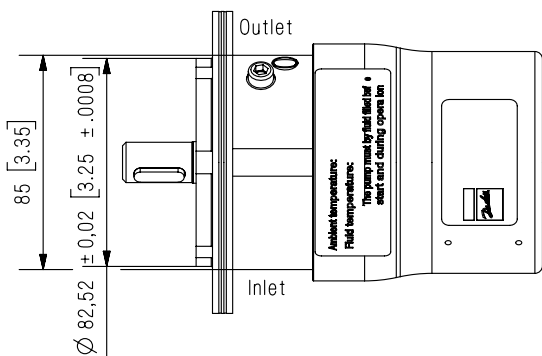
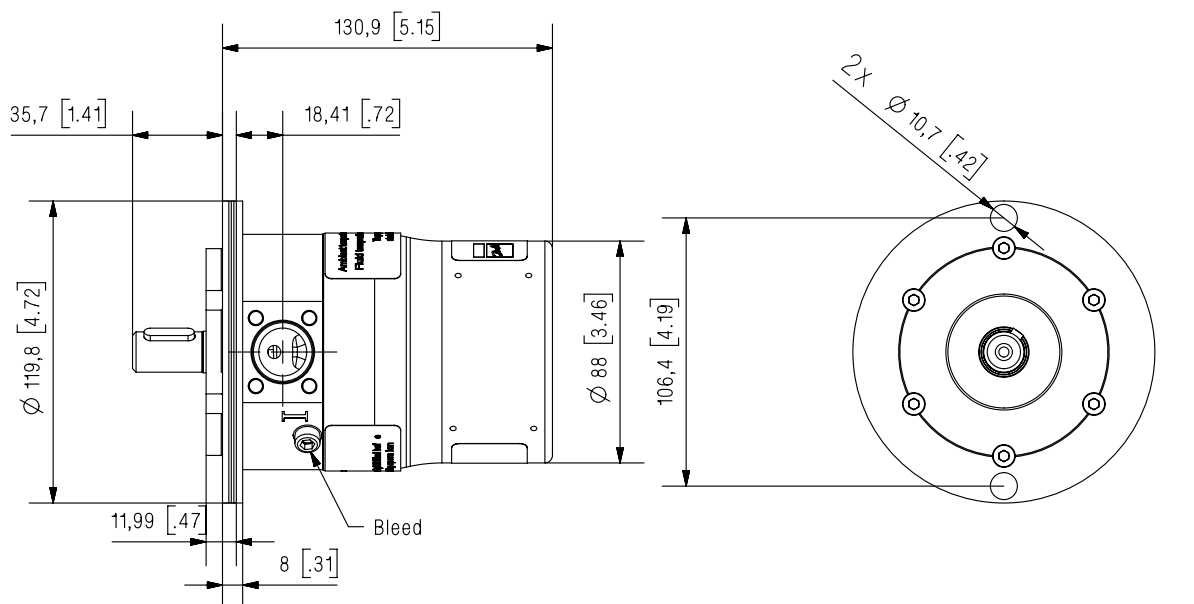

Dimensions without tolerances acc. to ISO 2768-1 designation C.

Description	CLP / CLP D-005-017
Parallel key	5 x 5 x 20 mm
Din 6885	0.2 x 0.2 x 0.79 inch
Bleed	M6; hex key 5 mm
Inlet port	1/2 inch
Outlet port	1/2 inch
Earth connection	2 x M8, depth 11 mm
Thermal sensor	M6, depth 11 mm

9.2 CLP / CLP D-025-058 pumps

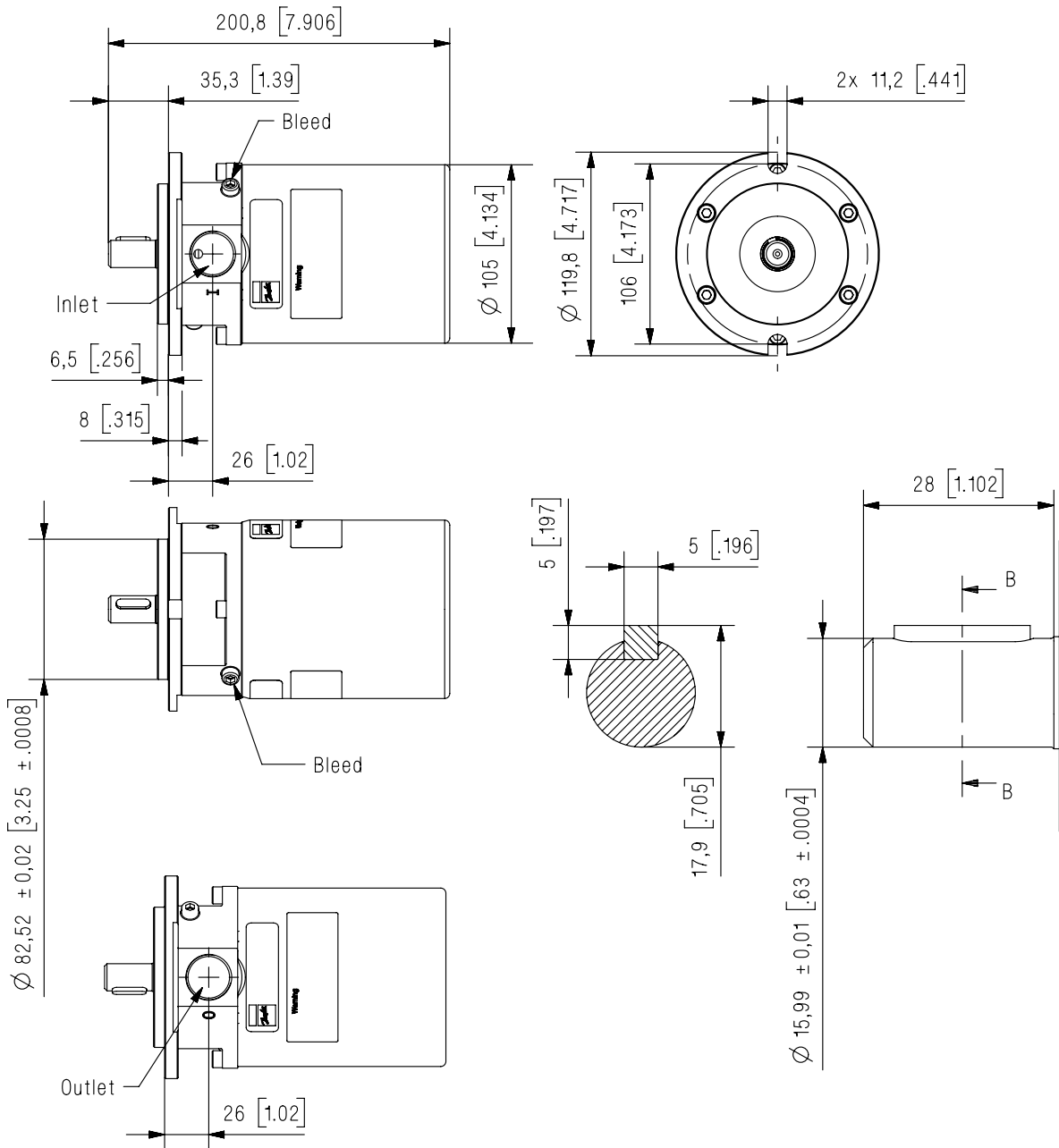

Dimensions without tolerances acc. To ISO 2768-1 designation C.

Description	CLP / CLP D-025-058
Parallel key DIN 6885	5 x 5 x 20 mm 0.2 x 0.2 x 0.79 inch
Bleed	M6 hex key 5 mm
Inlet	G 3/4"; depth 16 mm
Outlet	G 3/4"; depth 16 mm

9.3 CLP / CLP D-025-058 pumps with spline

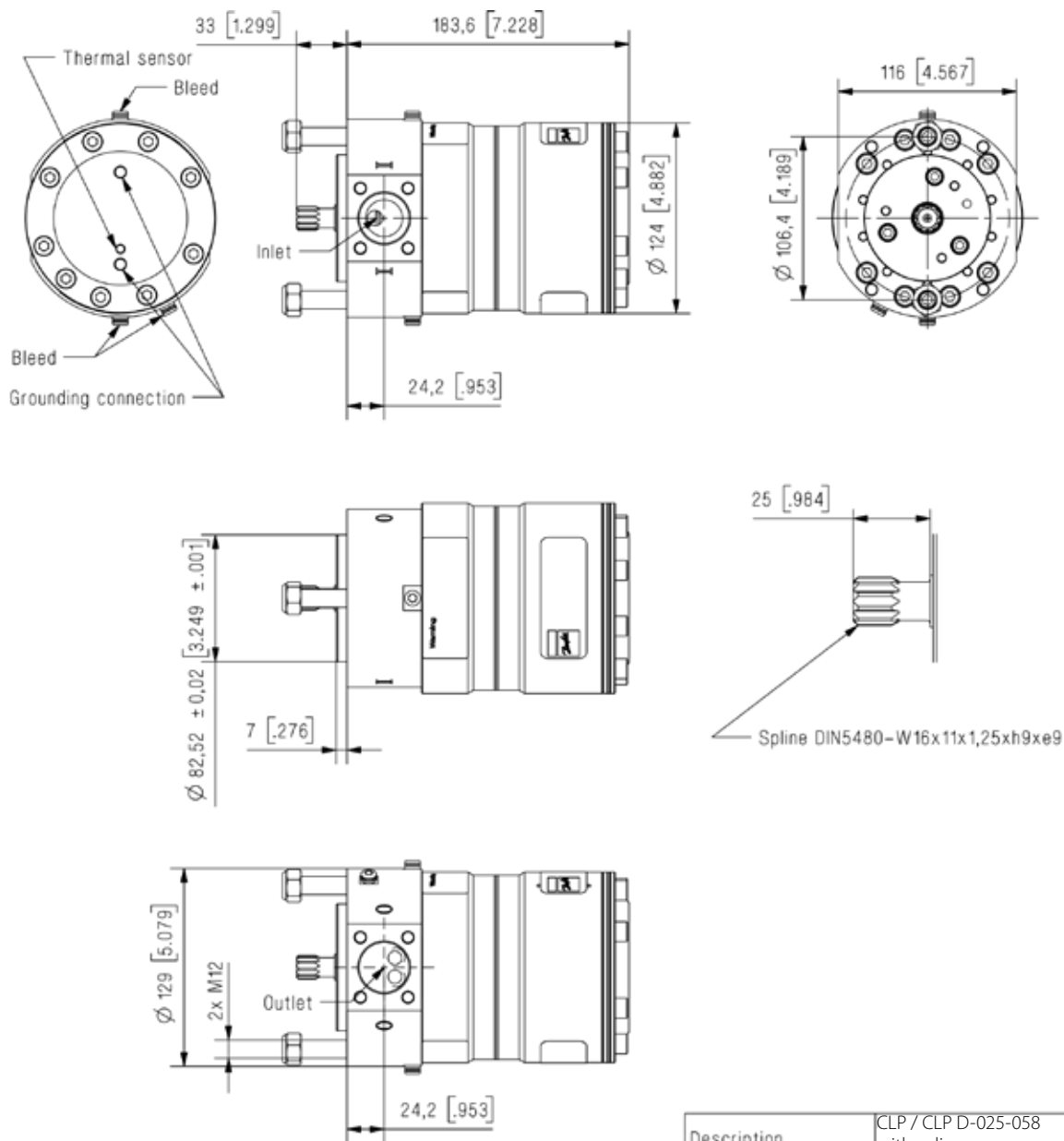

Dimensions without tolerances acc. to ISO 2768-1 designation C.

Description	CLP / CLP D-025-058 with spline
Spline DIN5480	W16x11x1, 25xh9xe9
Bleed	M6, hex key 5 mm
Inlet port	3/4 inch
Outlet port	3/4 inch
Grounding connection	M8, depth 10 mm
Thermal sensor	M6, depth 10 mm

9.3 CLP-055-080 pumps with spline

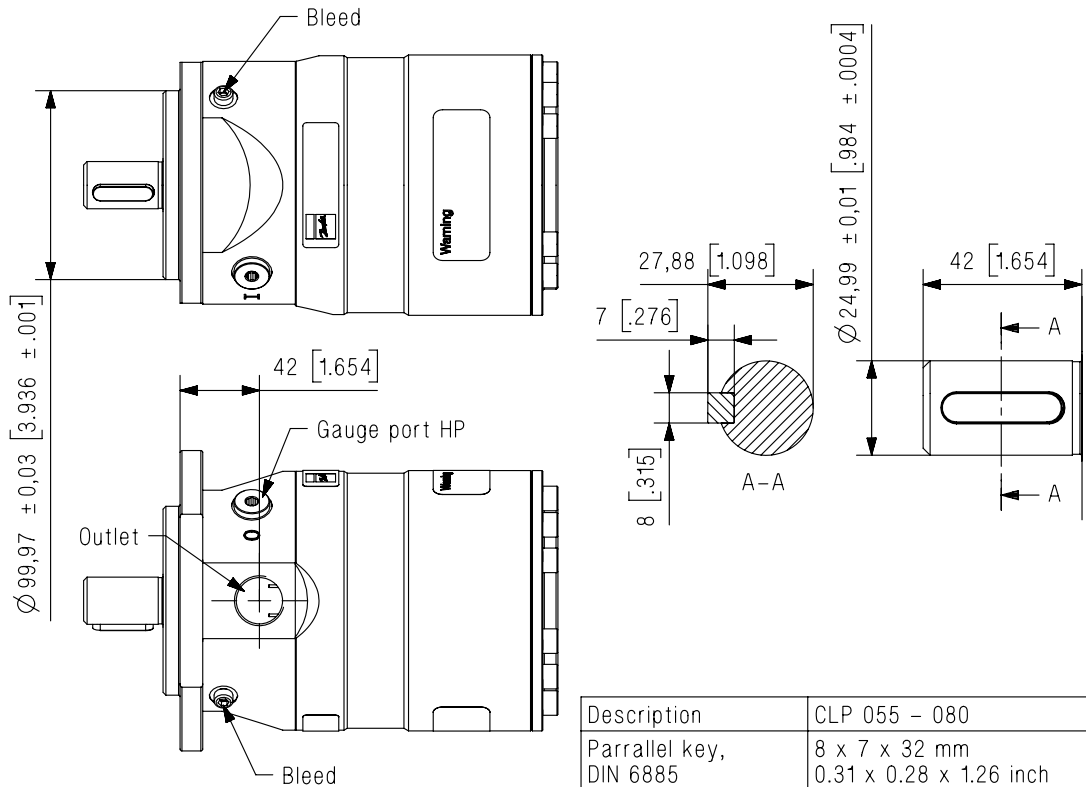
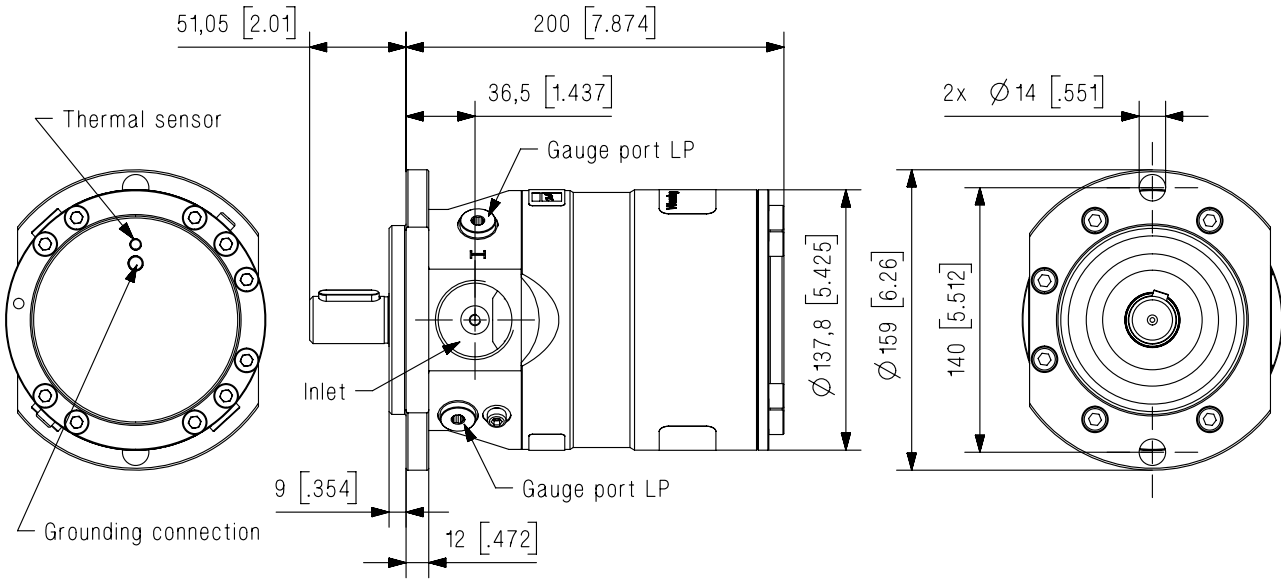

Description	CLP 055 - 080
Parrallel key,	8 x 7 x 32 mm
DIN 6885	0.31 x 0.28 x 1.26 inch
Bleed	M6; hex key 5 mm
Inlet port	G 1 1/4" BSPP; depth 20 mm
Outlet port	G 3/4" BSPP; depth 16 mm
Gauge port	G 1/4" BSPP; depth 15 mm
Grounding connection	M8, depth 11 mm
Thermal sensor	M6, depth 11 mm
Mounting flange	ISO 3019-2 100A2HW

Dimensions without tolerances acc. to ISO 2768-1 designation C.

9.5 CLP / CLP D-085-152 pumps

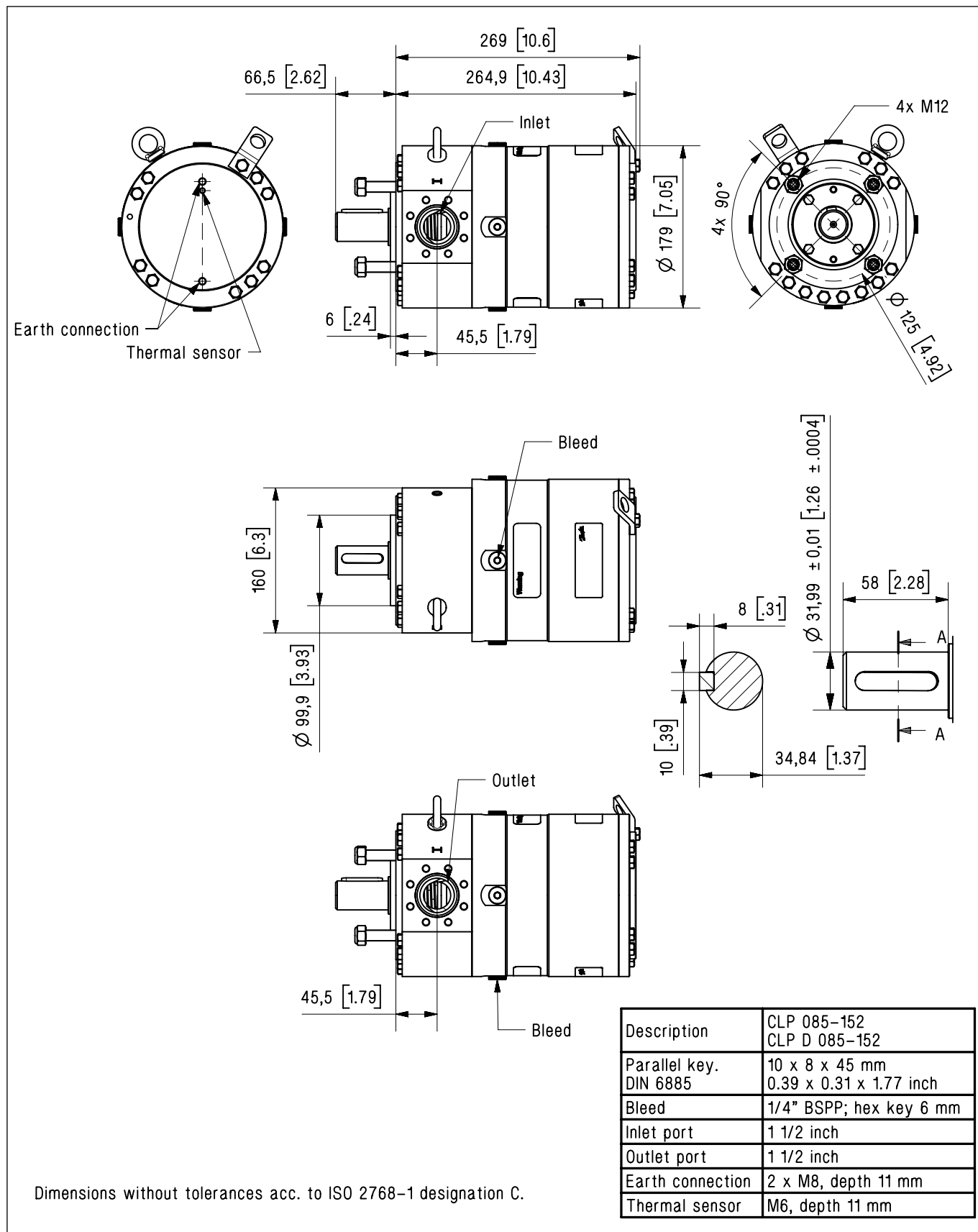

9.6 CLP / CLP D-140-500 pumps

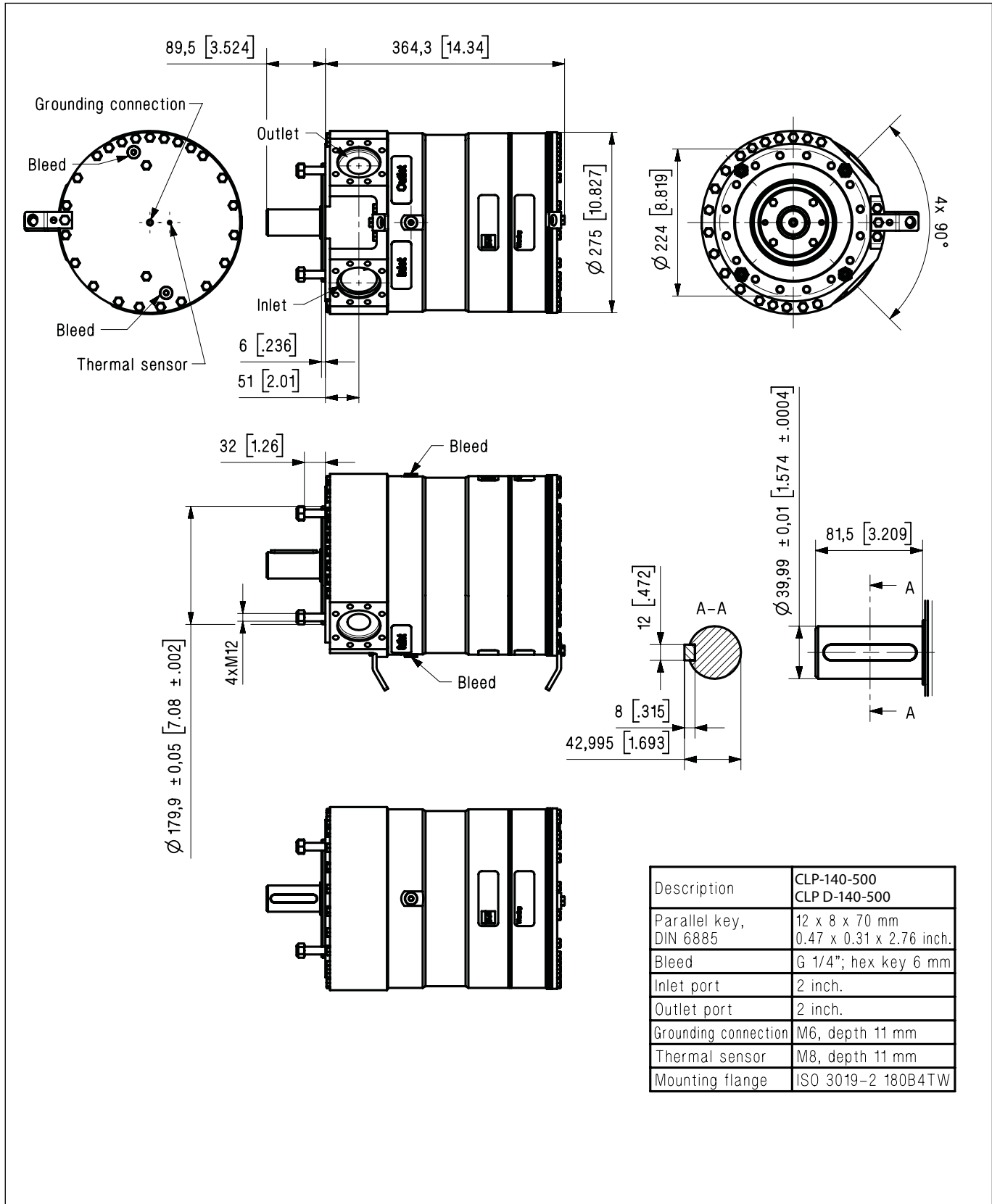



9.7 CLP D-580-1000 pumps

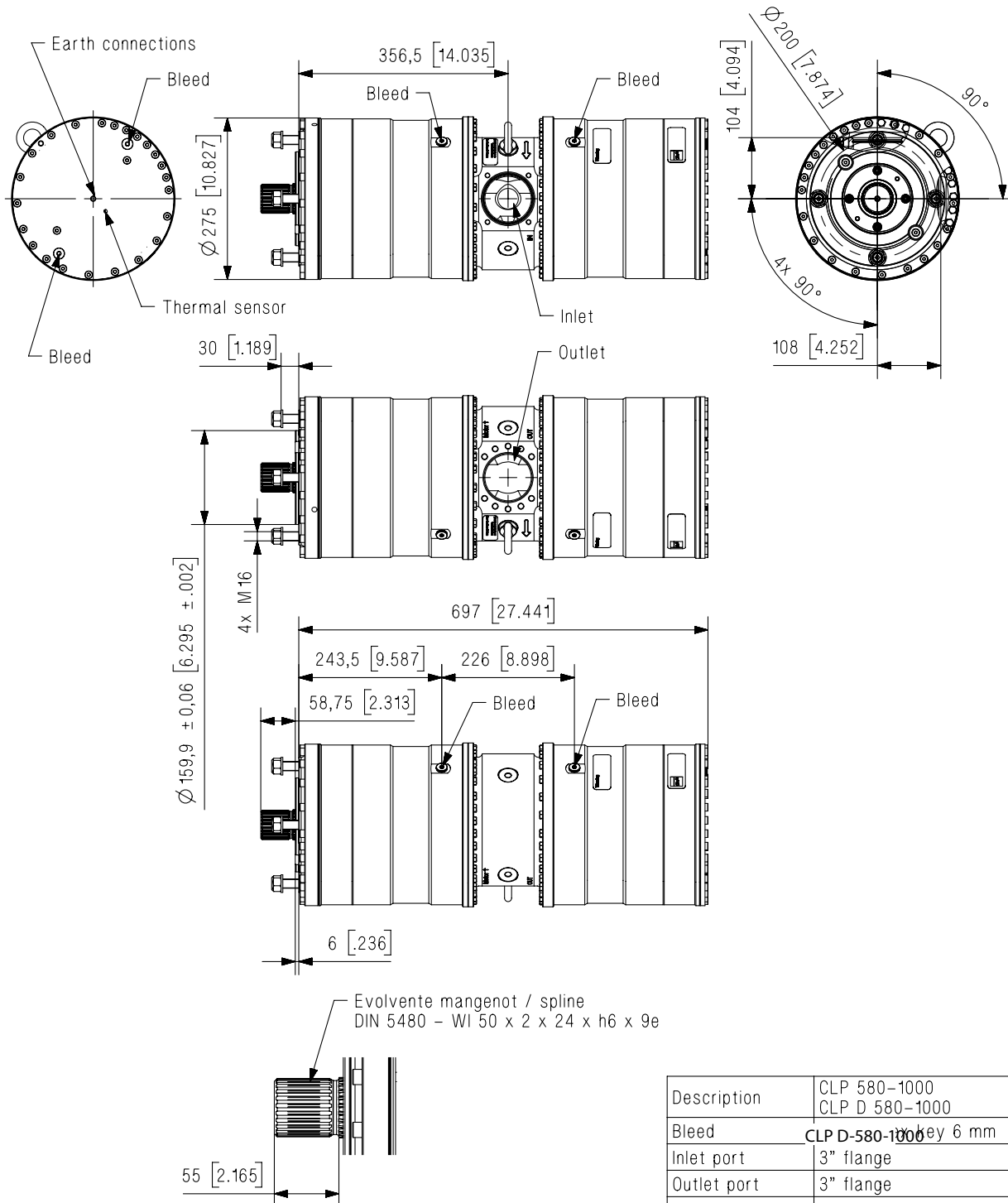

Dimensions without tolerances acc. to ISO 2768-1 designation C.

Description	CLP 580-1000 CLP D 580-1000
Bleed	CLP D-580-1000 key 6 mm
Inlet port	3" flange
Outlet port	3" flange
Earth connection	M6, depth 8 mm
Thermal sensor	M6, depth 8 mm

10. Pump and bell-housing

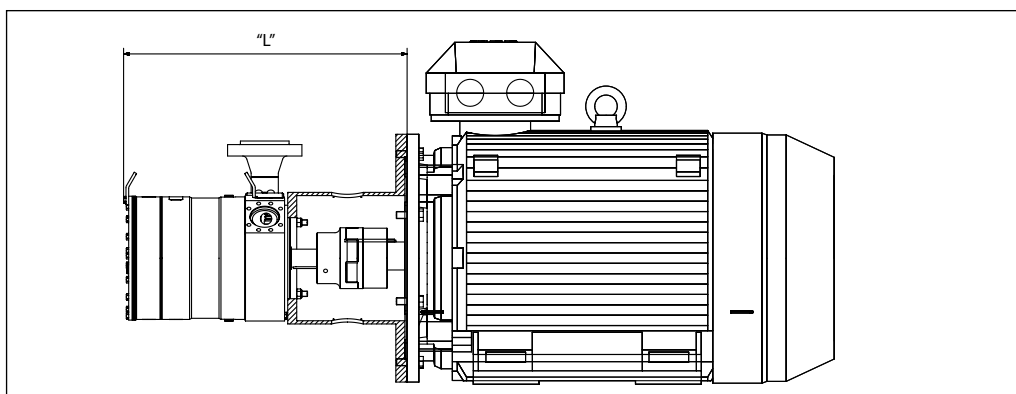

Pump type	Motor size	ICE size	Length 'L' [mm]	Length 'L' [in]
CLP-055-080	5,5 kW	132S	350	13.8
CLP-055-080	15 kW	160L	388	15.3
CLP / CLP D-005-017	0.75 kW	80	254.5	10.0
CLP / CLP D-005-017	1.1 kW	90S	259.5	10.2
CLP / CLP D-005-017	1.5 kW	90L	259.5	10.2
CLP / CLP D-005-017	2.2 kW	100L	279.5	11.0
CLP / CLP D-005-017	3 kW	100L	279.5	11.0
CLP / CLP D-025-058	3 kW	100L	302	11.9
CLP / CLP D-025-058	4 kW	112M	302	11.9
CLP / CLP D-025-058	5.5 kW	132S	327	12.9
CLP / CLP D-025-058	7.5 kW	132S	327	12.9
CLP / CLP D-025-058	11 kW	160M	371	14.6
CLP / CLP D-085-152	7,5 kW	132M	437	17.2
CLP / CLP D-085-152	15 kW	160L	473	18.6
CLP / CLP D-085-152	30 kW	200L	473	18.6
CLP / CLP D-085-152	55 kW	250M	517	20.4
CLP / CLP D-140-500	30 kW	200L	592	23.3
CLP / CLP D-140-500	55 kW	250M	629	24.8
CLP / CLP D-140-500	132 kW	315L	674	26.5
CLP / CLP D-140-500	200 kW	315L	674	26.5
CLP D-580-1000	280 kW	355M	1007	39.6

11. Pump base plate solution

Danfoss High Pressure Pumps can provide a standard baseplate for all standard motor pump units. Custom made baseplates are available on request.

Contact Danfoss High Pressure Pumps for price and leadtime.

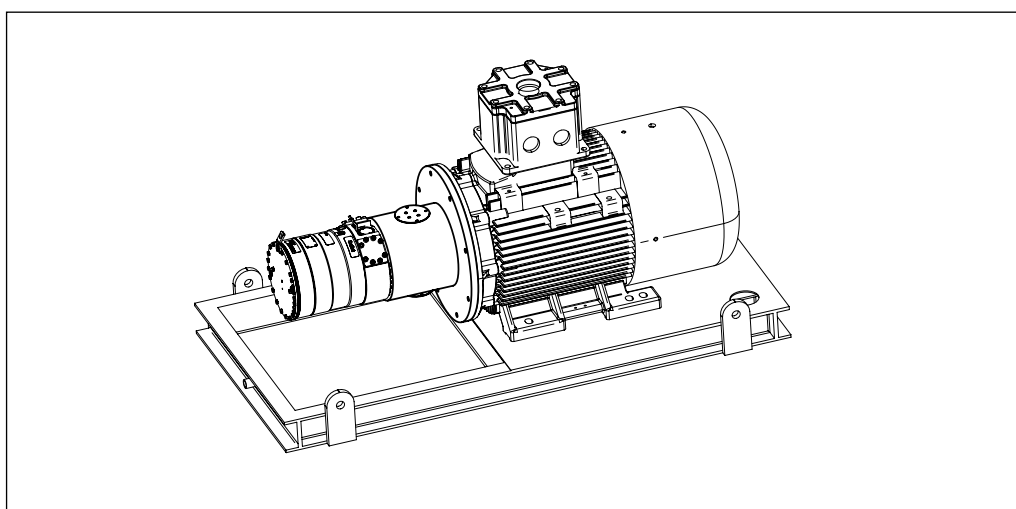



Danfoss A/S  
High Pressure Pumps  
Nordborgvej 81  
DK-6430 Nordborg  
Denmark

---

Danfoss can accept no responsibility for possible errors in catalogues, brochures and other printed material. Danfoss reserves the right to alter its products without notice. This also applies to products already on order provided that such alterations can be made without subsequential changes being necessary in specifications already agreed.  
All trademarks in this material are property of the respective companies. Danfoss and the Danfoss logotype are trademarks of Danfoss A/S. All rights reserved.

---