

Data sheet

Shut-off valves

Types SVA-S and SVA-L



SVA shut-off valves are available in angleway and straightway versions and with Standard neck (SVA-S) and Long neck (SVA-L)

The shut-off valves are designed to meet all industrial refrigeration application requirements and are designed to give favourable flow characteristics and are easy to dismantle and repair when necessary.

The valve cone is designed to ensure perfect closing and withstand a high system pulsation and vibration, which can be present specifically in the discharge line.

Features

- Applicable to HCFC, HFC, R717 (Ammonia), R744 (CO₂) and all flammable refrigerants.
- Modular Concept:
 - Each valve housing is available with several different connection types and sizes.
 - Possible to convert SVA-S or SVA-L to any other product in the Flexline™ SVL family (hand operated regulating valve, check & stop valve, check valve or strainer) just by replacing the complete top part.
- Fast and easy valve overhaul service. It is easy to replace the top part and no welding is needed.
- Optional accessories:
 - Heavy duty industrial hand wheel for frequent operation.
 - Cap for infrequent operation.
- Available in angleway and straightway versions with Standard neck or Long neck (DN 15 to DN 40) for insulated systems.
- Each valve type is clearly marked with type, size and performance range.
- The valves and caps are prepared for sealing, to prevent operation by unauthorized persons, using a seal wire.
- Internal metal backseating:
 - DN 6 - 65 (¼ - 2½ in.)
- Internal PTFE backseating:
 - DN 80 - 200 (3 - 8 in.)
- Can accept flow in both directions.
- Housing and bonnet material is low temperature steel according to requirements of the Pressure Equipment Directive and other international classification authorities.
- Equipped with stainless steel bolts.
- Max. working pressure: 52 barg / 754 psig
- Temperature range: -60 – 150 °C / -76 – 302 °F
- Classification: DNV, CRN, BV, EAC etc. To get an updated list of certification on the products please contact your local Danfoss Sales Company.

Design
Connections

Available with the following connections:

- Butt-weld ANSI (B 36.10 Schedule 80), DN 6 - 40 (¼ - 1½ in.)
- Butt-weld ANSI (B 36.10 Schedule 40), DN 50 - 200 (2 - 8 in.)
- Socket Weld (ANSI B 16.11), DN 15 - DN 50 (½ - 2 in.)
- FPT Female Pipe Thread, NPT (ANSI/ASME B 1.20.1), DN 15 - 32 (½ - 1¼ in.)

Housing

Made of special, cold resistant steel.

Valve cone

The valve cone can be turned on the spindle, thus there will be no friction between the cone and the seat when the valve is opened and closed and the special design will avoid cone spin due to pulsation and vibration when the valve is in open position. A teflon tightening ring provides perfect sealing with minimum closing force.

Spindle

Made of polished stainless steel, ideal for leap seal sealing.

Packing gland

The low temperature packing gland ensures a perfect tightness in the range: -60 – 150 °C / -76 – 302 °F. The packing glands are equipped with a scraper ring to prevent penetration of dirt and ice into the packing gland.

Pressure Equipment Directive (PED)

SVA valves are approved according to the European standard specified in the Pressure Equipment Directive and are CE marked.

For further details / restrictions - see Installation Instruction.

Installation

It is recommended that the valves be installed in the direction of flow indicated by the arrow on the valve body. The valve can be installed in the opposite direction but this slightly reduces the k_v -value (C_v -value).

The valve is designed to withstand high internal pressure. However, the piping system in general should be designed to avoid liquid traps and reduce the risk of hydraulic pressure caused by thermal expansion.

For further information refer to installation instructions for SVA.

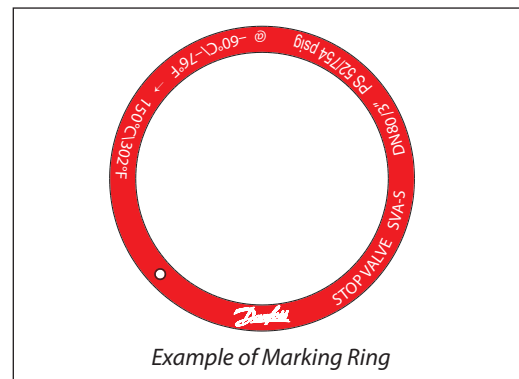

SVA			
Nominal bore	DN ≤ 25 mm (1 in.)	DN 32-80 mm (1¼ - 3 in.)	DN 100 - 200 mm (4-8 in.)
Classified for	Fluid group I		
Category	Article 3, paragraph 3	II	III

Data sheet | Shut-off valves, types SVA-S and SVA-L
Technical data

- Refrigerants
Applicable to HCFC, HFC, R717 (Ammonia), R744 (CO₂) and all flammable refrigerants.
- Temperature range
-60 – 150 °C / -76 – 302 °F.
- Max. working pressure
52 barg / 754 psig.

Connections

Size mm	Size in.	OD mm	T mm	OD in.	T in.			k _v -angle m ³ /h	k _v -straight m ³ /h	C _v -angle USgal/min	C _v -straight USgal/min
---------	----------	-------	------	--------	-------	--	--	--	---	------------------------------------	---------------------------------------

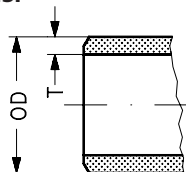
ANSI

Butt-weld ANSI (B 36.10 Schedule 80)

6	¼	13.5	3.0	0.531	0.118			2.9	2.03	3.4	2.4
10	⅜	17.2	3.2	0.677	0.126			4.5	3.15	5.2	3.6
15	½	21.3	3.7	0.839	0.146			7.0	4.9	8.1	5.7
20	¾	26.9	4.0	1.059	0.158			14.6	10.2	16.9	11.8
25	1	33.7	4.6	1.327	0.181			24.8	17.4	28.8	20.2
32	1¼	42.4	4.9	1.669	0.193			42.6	29.8	49.4	34.6
40	1½	48.3	5.1	1.902	0.201			45.2	31.6	52.4	36.7

Butt-weld ANSI (B 36.10 Schedule 40)

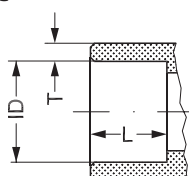
50	2	60.3	3.9	2.37	0.15			80	65	93	76
65	2½	73.0	5.2	2.87	0.20			120	97	140	113
80	3	88.9	5.5	3.50	0.22			182	152	211	176
100	4	114.3	6.0	4.50	0.24			313	278	363	323
125	5	141.3	6.6	5.56	0.26			514	470	596	545
150	6	168.3	7.1	6.63	0.28			785	597	911	693
200	8	219.1	8.2	8.63	0.32			1168	1024	1355	1188

SOC

Socket welding ANSI (B 16.11)

15	½	21.8	6.0	0.858	0.235	10	0.39	7.0	4.9	8.1	5.7
20	¾	27.2	4.6	1.071	0.181	13	0.51	14.6	10.9	16.9	11.8
25	1	33.9	7.2	1.335	0.284	13	0.51	24.8	17.4	28.8	20.2
32	1¼	42.7	6.1	1.743	0.240	13	0.51	42.6	29.8	49.4	34.6
40	1½	48.8	6.6	1.921	0.260	13	0.51	45.2	31.6	52.4	36.7
50	2	61.2	6.2	2.41	0.24	16	0.63	80	65	93	76

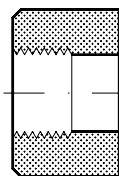
Size mm	Size in.	Inside pipe tread			k _v -angle m ³ /h	k _v -straight m ³ /h	C _v -angle USgal/min	C _v -straight USgal/min
---------	----------	-------------------	--	--	--	---	------------------------------------	---------------------------------------

FPT

FPT inside pipe thread, NPT (ANSI/ASME B 1.20.1)

15	½	(½ × 14 NPT)			8.5	6.0	9.9	7.0
20	¾	(¾ × 14 NPT)			10	7.0	11.6	8.1
25	1	(1 × 11.5 NPT)			32	22.4	37.1	26.0
32	1¼	(1¼ × 11.5 NPT)			36	25.2	41.8	29.3

Material specification

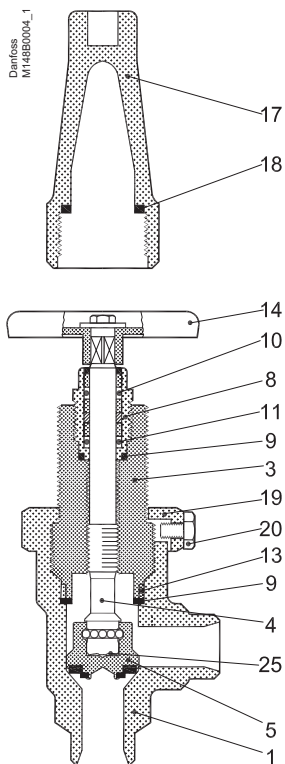
SVA-S 6-10 (1/4 - 3/8 in.)



SVA-S 15-20 (1/2 - 3/4 in.)

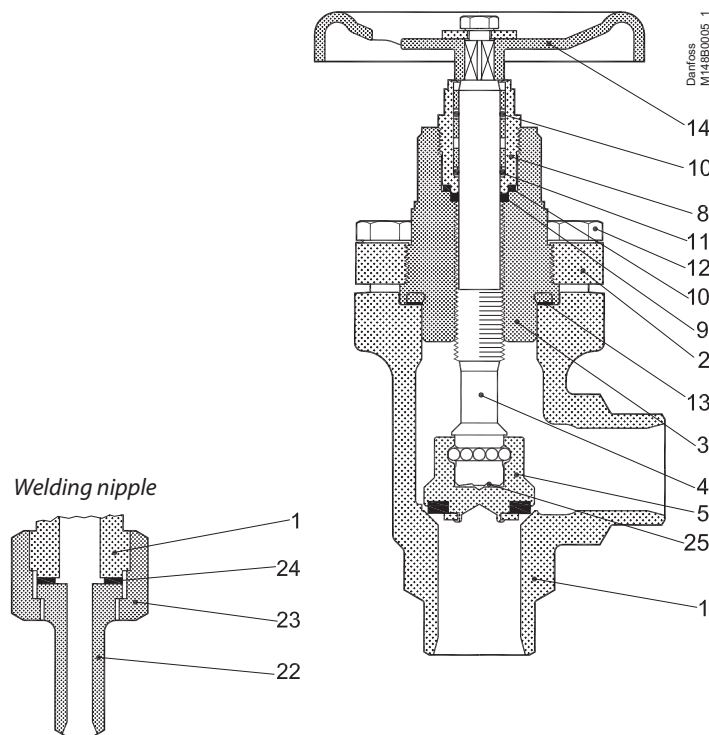

No.	Part	Material	EN	ISO	ASTM
1	Housing	Steel	G20Mn5QT, 10213-3		LCC, A352
			P285QH+QT, 10222-4		LF2, A350
2	Bonnet, Flange	Steel	G20Mn5QT, 10213-3		LCC, A352
			P285QH+QT, 10222-4		LF2, A350
			P275NL, 10028-3		
3	Bonnet, Insert	Steel	11SMn30 10087	Type 2 R 683/9	AISI 1213
4	Spindle	Stainless steel	X8CrNiS18-9 10088	Type 17 683/13	AISI 303
5	Cone	Steel	11SMn30 10087	Type 2 R 683/9	AISI 1213
8	Packing gland	Stainless steel	X8CrNiS18-9 10088	Type 17 683/13	AISI 303
9	Packing washer	Aluminium			
10	O-ring	Cloroprene (Neoprene)			
11	Spring loaded Teflon ring	PTFE			
12	Bolts	Stainless steel	A2-70	A2-70	Type 308
13	Gasket	Fiber, Non-asbestos			
14	Handwheel	Steel			
17	Cap	Aluminium			
18	Gasket for cap	Nylon			
19	Locking nut	Steel			
20	Screw	Steel			
22	Welding nipple	Steel	S235JRG2 10025	Fe260B, 630	Grade C, A 283
23	Nut	Steel	11SMn30 10087	Type 2 R 683/9	AISI 1213
24	Packing washer	Non-asbestos			
25	Disk spring	Steel			

Material specification

SVA-S 25-40 (1 - 1½ in.)

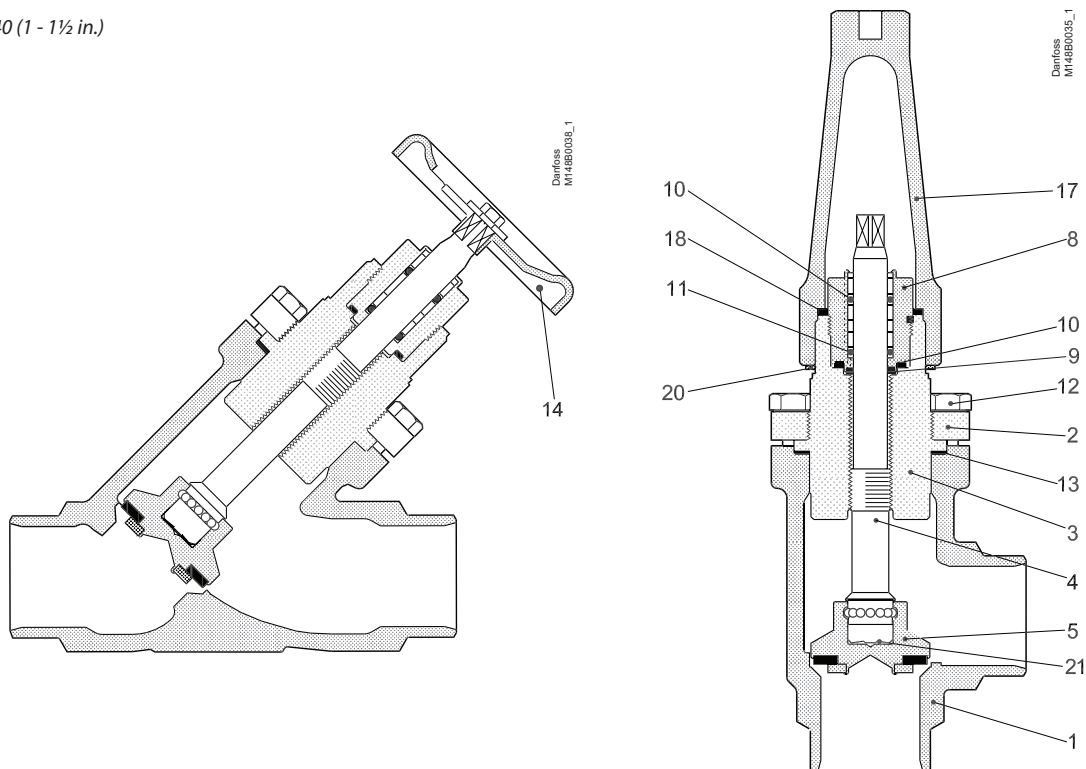

No.	Part	Material	EN	ISO	ASTM
1	Housing	Steel	G20Mn5QT, 10213-3 ----- P285QH+QT, 10222-4		LCC, A352 ----- LF2, A350
2	Bonnet, Flange	Steel	G20Mn5QT, 10213-3 ----- P285QH+QT, 10222-4 ----- P275NL, 10028-3		LCC, A352 ----- LF2, A350
3	Bonnet, Insert	Steel	11SMn30 10087	Type 2 R 683/9	AISI 1213
4	Spindle	Stainless steel	X8CrNiS18-9 10088	Type 17 683/13	AISI 303
5	Cone	Steel	11SMn30 10087	Type 2 R 683/9	AISI 1213
8	Packing gland	Stainless steel	X8CrNiS18-9 10088	Type 17 683/13	AISI 303
9	Packing washer	Aluminium			
10	O-ring	Cloroprene (Neoprene)			
11	Spring loaded Teflon ring	PTFE			
12	Bolts	Stainless steel	A2-70	A2-70	Type 308
13	Gasket	Fiber, Non-asbestos			
14	Handwheel	Steel			
17	Cap	Aluminium			
18	Gasket for cap	Nylon			
20	Identification ring	Stainless steel			
21	Disk spring	Steel			

Material specification

SVA-L 15 - 40 (1/2 - 1 1/2 in.)

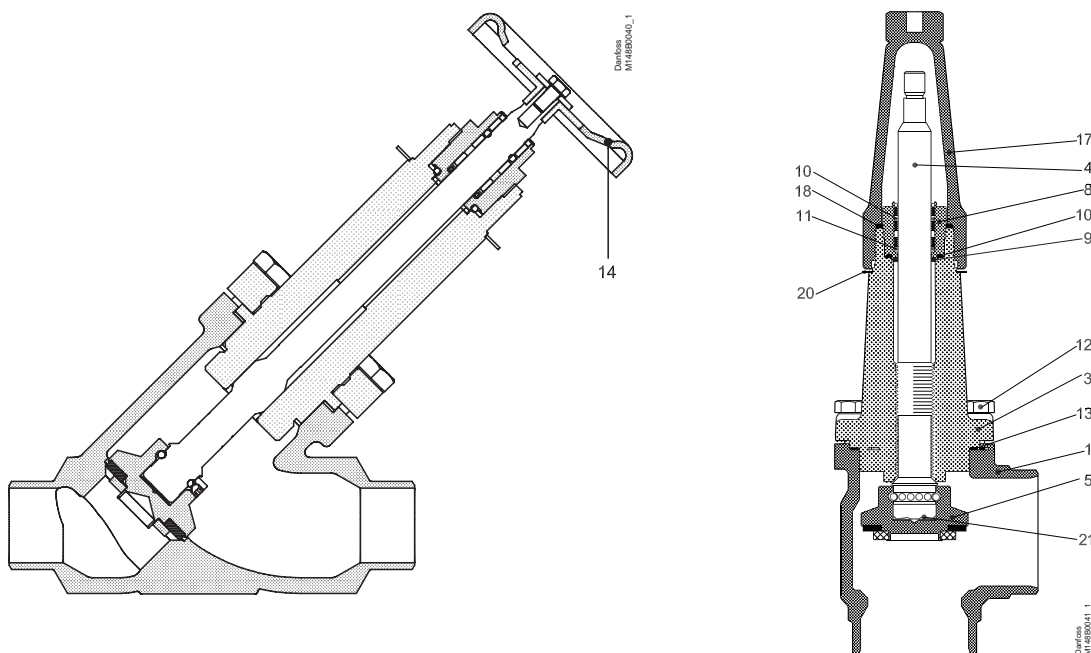

No.	Part	Material	EN	ISO	ASTM
1	Housing	Steel	G20Mn5QT, 10213-3 P285QH+QT, 10222-4		LCC, A352 LF2, A350
3	Valve bonnet	Steel	G20Mn5QT, 10213-3 P285QH+QT, 10222-4		LCC, A352 LF2, A350
4	Spindle	Stainless steel	X8CrNiS18-9 10088	Type 17 683/13	AISI 303
5	Cone	Steel	11SMn30 10087	Type 2 R 683/9	AISI 1213
8	Packing gland	Stainless steel	X8CrNiS18-9 10088	Type 17 683/13	AISI 303
9	Packing washer	Aluminium			
10	O-ring	Cloroprene (Neoprene)			
11	Spring loaded Teflon ring	PTFE			
12	Bolts	Stainless steel	A2-70	A2-70	Type 308
13	Gasket	Fiber, Non-asbestos			
14	Hand wheel	Steel			
17	Cap	Aluminium			
18	Gasket for cap	Nylon (PA6)			
20	Identification ring	Stainless steel			
21	Disk spring	Steel			

Material specification

SVA-S 50-65 (2 - 2½ in.)

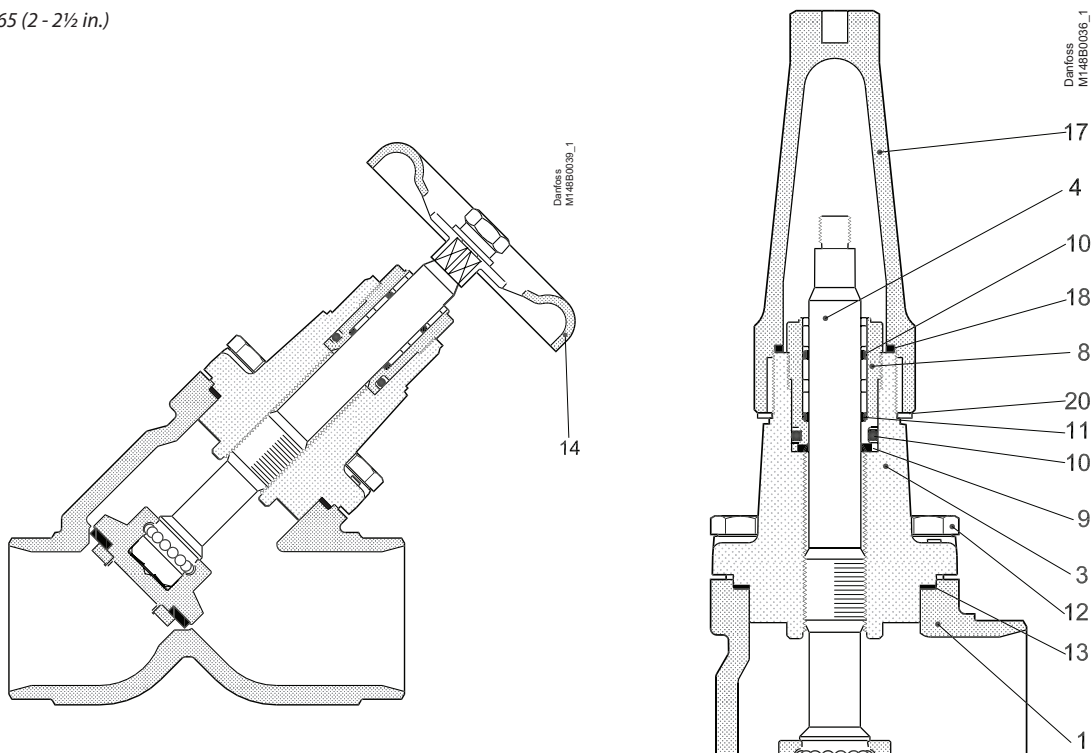

No.	Part	Material	EN	ISO	ASTM
1	Housing	Steel	G20Mn5QT, 10213-3 ----- P285QH+QT, 10222-4		LCC, A352 ----- LF2, A350
3	Valve bonnet	Steel	G20Mn5QT, 10213-3 ----- P285QH+QT, 10222-4		LCC, A352 ----- LF2, A350
4	Spindle	Stainless steel	X8CrNiS18-9 10088 DIN 17440 (SVA-SS only)	Type 17 683/13	AISI 303
5	Cone	Steel	11SMn30 10087	Type 2 R 683/9	AISI 1213
8	Packing gland	Stainless steel	X8CrNiS18-9 10088	Type 17 683/13	AISI 303
9	Packing washer	Aluminium			
10	O-ring	Cloroprene (Neoprene)			
11	Spring loaded Teflon ring	PTFE			
12	Bolts	Stainless steel	A2-70	A2-70	Type 308
13	Gasket	Fiber, Non-asbestos			
14	Handwheel	Steel			
17	Cap	Aluminium			
18	Gasket for cap	Nylon			
19	Locking nut	Steel			
20	Identification ring	Stainless steel			
21	Disk spring	Steel			

Material specification

SVA-S 80 - 150 (3 - 6 in.)

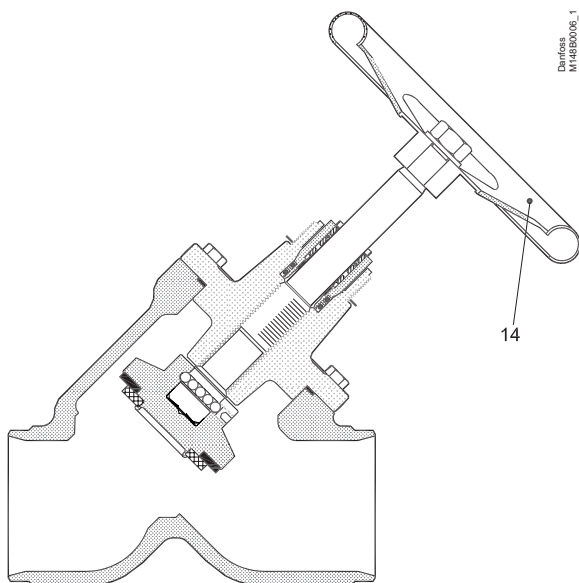

Danfoss
M148BX006_1

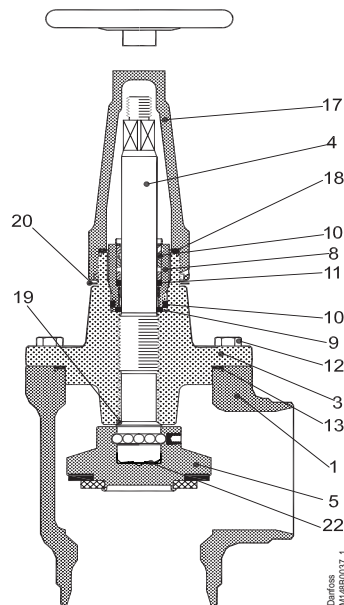

Danfoss
M148BX007_1

No.	Part	Material	EN	ISO	ASTM
1	Housing	Steel	G20Mn5QT 10213-3		LCC A352
3	Valve bonnet	Steel	G20Mn5QT, 10213-3 ----- P285QH+QT, 10222-4		LCC, A352 ----- LF2, A350
4	Spindle	Stainless steel	X5CrNi18-10 10088	Type 11, R 683/13	AISI 304, A276
5	Cone Cone seal	Steel Teflon (PTFE)	11SMn30 10087	Type 2, R 683/9	AISI 1213
8	Packing gland	Stainless steel	X8CrNiS18-9 10088	Type 17 R 683/13	AISI 303
9	Packing washer	Aluminium			
10	O-ring	Cloroprene (Neoprene)			
11	Spring loaded Teflon ring	PTFE			
12	Bolts	Stainless steel	A2-70	A2-70	Type 308
13	Gasket	Fiber, Non-asbestos			
14	Hand wheel	Steel			
17	Cap	Aluminium			
18	Gasket for cap	Nylon (PA 6)			
19	Soft backseat	Teflon (PTFE)			
20	Identification ring	Stainless steel			
22	Disk spring	Steel			

Material specification

SVA-S 200 (8 in.)

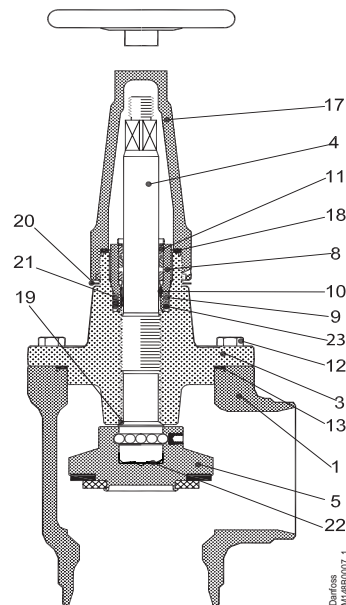
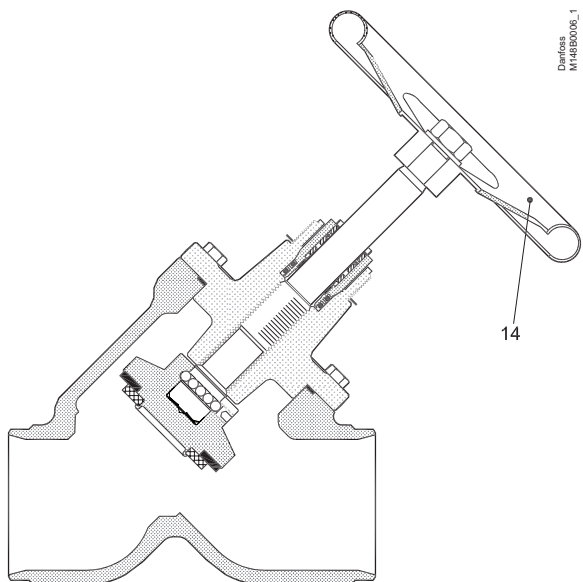

No.	Part	Material	EN	ISO	ASTM
1	Housing	Steel	G20Mn5QT 10213-3		LCC A352
3	Valve bonnet	Steel	SVA 80: G20Mn5QT SVA 100: P285QH+QT SVA 125: P285QH+QT SVA 150: P285QH+QT		SVA 80: LCC, A352 SVA 100: LF2, A350 SVA 125: LF2, A350 SVA 150: LF2, A350
4	Spindle	Stainless steel	X5CrNi18-10 10088	Type 11, R 683/13	AISI 304, A276
5	Cone Cone seal	Steel Teflon (PTFE)	11SMn30 10087	Type 2, R 683/9	AISI 1213
8	Packing gland	Stainless steel	X8CrNiS18-9 10088	Type 17 R 683/13	AISI 303
9	O-ring	Cloroprene (Neoprene)			
10	Spring loaded Teflon ring	PTFE			
11	O-ring	Cloroprene (Neoprene)			
12	Bolts	Stainless steel	A2-70	A2-70	Type 308
13	Gasket	Fiber, Non-asbestos			
14	Hand wheel	Steel			
15	Washer	Stainless steel			
16	Nut	Stainless steel			
17	Cap	Aluminium			
18	Gasket for cap	Nylon (PA 6)			
19	Soft backseat	Teflon (PTFE)			
20	Identification ring	Stainless steel			
21	Wear ring	Teflon (PTFE)			
22	Disk spring	Steel			
23	O-ring	PTFE/Cloroprene (Neoprene)			

Dimensions and weights

SVA 6-10 in angle execution with handwheel

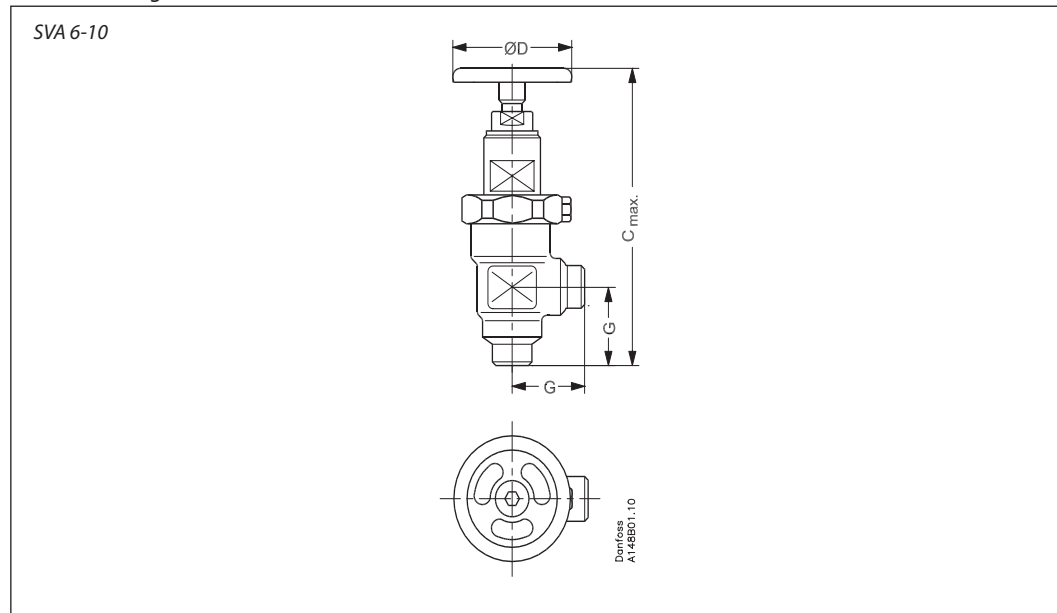

Valve size			$C_{max.}$	G	$\varnothing D$	$\square H$	Weight
SVA 6	mm		128	30	50		0.7 kg
	in.		5.04	1.18	1.97		
SVA 10	mm		173	45	60	60	1.4 kg
	in.		6.81	1.77	2.36	2.36	

SVA 6-10 in angle execution with cap

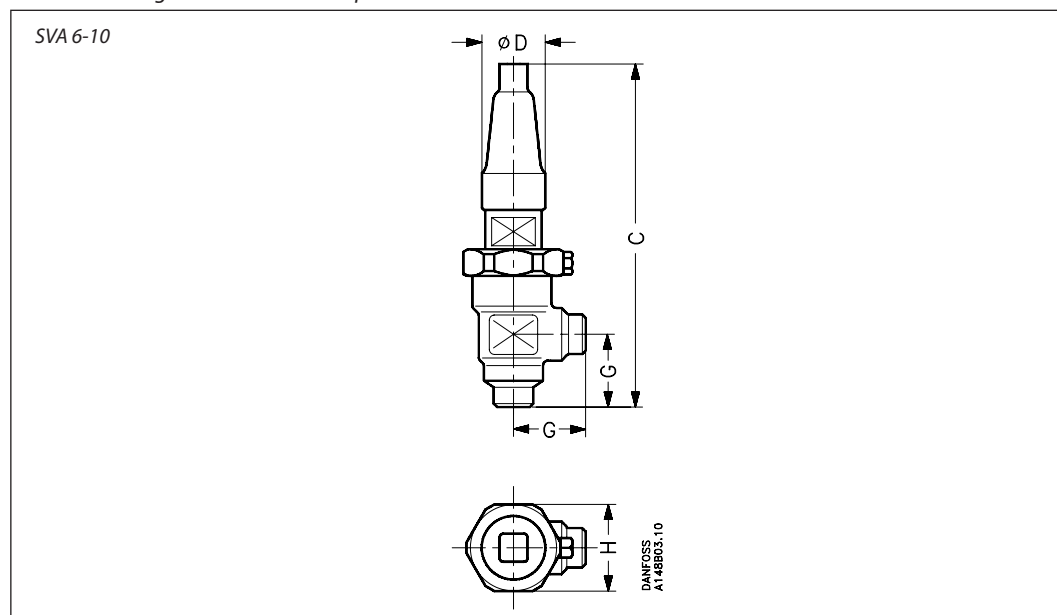

Valve size			C	G	$\varnothing D$	$\square H$	Weight
SVA 6	mm		139	30	30	48	0.8 kg
	in.		5.47	1.18	1.18	1.89	
SVA 10	mm		182	45	38	60	1.4 kg
	in.		7.17	1.77	1.50	2.36	

Specified weights are approximate values only.

Dimensions and weights

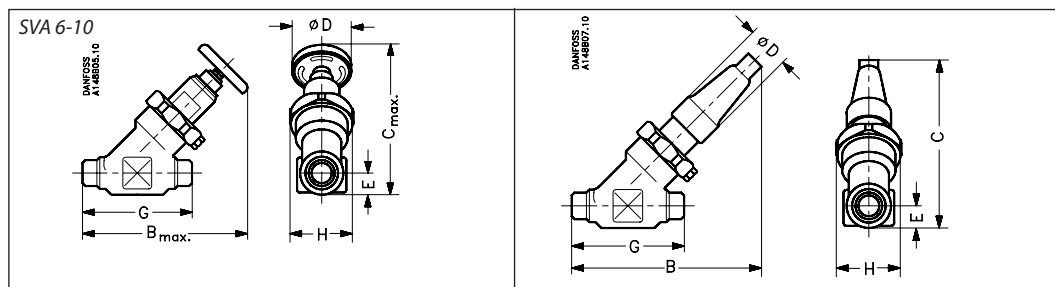

SVA 6 - 10 in straight-way execution with handwheel

Valve size		C _{max.}	B _{max.}	E	G	ØD	H	Weight
SVA 6	mm	110	120	13	70	50	48	0.7 kg
	in.	4.33	4.72	0.49	2.76	1.97	1.89	
SVA 10	mm	145	160	20	120	60	60	2.0 kg
	in.	5.71	6.30	0.79	4.72	2.36	2.36	

SVA 6 - 10 in straight-way execution with cap

Valve size		C	B	E	G	ØD	H	Weight
SVA 6	mm	110	120	13	70	30	48	0.8 kg
	in.	4.33	4.72	0.49	2.76	1.16	1.89	
SVA 10	mm	145	155	20	120	38	60	2.0 kg
	in.	5.71	6.10	0.79	4.72	1.50	2.36	

Specified weights are approximate values only.

Dimensions and weights

SVA 15 - 40 (½ - 1½ in.) in angleway version with cap / hand wheel

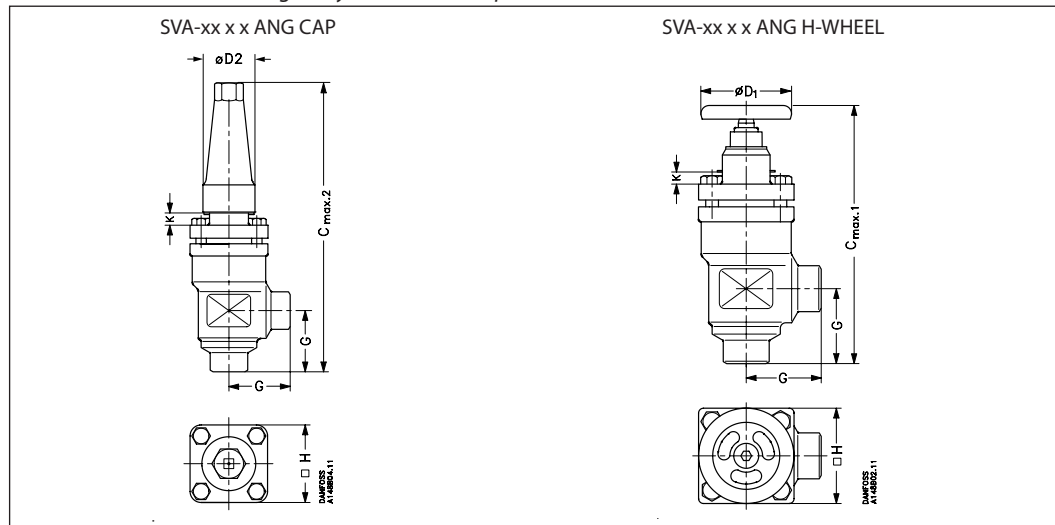

Valve size	K	C _{max.1}	C _{max.2}	G	øD ₁	øD ₂	H	Weight
SVA-S								
SVA 15 - 20	mm 4	178	189	45	60	38	60	1.4 kg
SVA (½ - ¾)	in. 0.16	7.00	7.44	1.77	2.36	1.5	2.36	3.1 lb
SVA 25 - 40	mm 12	234	268	55	80	50	70	2.4 kg
SVA (1 - 1½)	in. 0.47	9.21	10.55	2.17	3.15	1.97	2.76	5.3 lb
SVA-S, Socket weld								
SVA 32 - 40	mm 12	241	275	62	80	50	70	2.9 kg
SVA (1¼ - 1½)	in. 0.47	9.49	10.83	2.44	3.15	1.97	2.76	6.4 lb
SVA-L								
SVA 15 - 20	mm 63	237	248	45	60	38	60	1.4 kg
SVA (½ - ¾)	in. 2.48	9.33	9.76	1.77	2.36	1.5	2.36	3.1 lb
SVA 25 - 40	mm 74	296	330	55	80	50	70	2.4 kg
SVA (1 - 1½)	in. 2.91	11.65	12.99	2.17	3.15	1.97	2.76	5.3 lb
SVA-L, Socket weld								
SVA 32 - 40	mm 74	303	337	62	80	50	70	2.9 kg
SVA (1¼ - 1½)	in. 2.91	11.93	13.27	2.44	3.15	1.97	2.76	6.4 lb

Specified weights are approximate values only.

Dimensions and weights

SVA 15 - 40 (½ - 1½ in.) straightway version with cap / hand wheel

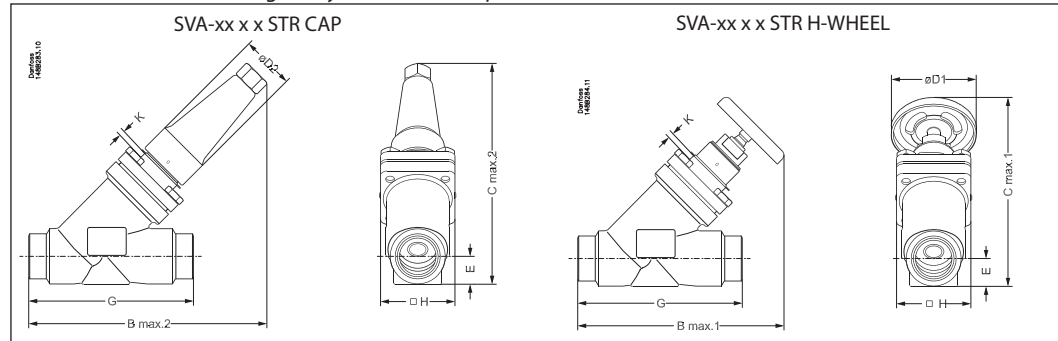

Valve size	K	C _{max.1}	C _{max.2}	B _{max.1}	B _{max.2}	E	G	∅D ₁	∅D ₂	□H	Weight
------------	---	--------------------	--------------------	--------------------	--------------------	---	---	-----------------	-----------------	----	--------

SVA-S

SVA 15 - 20	mm	4	146	141	160	156	20	120	60	38	60	2.0 kg
SVA (½ - ¾)	in.	0.16	5.74	5.55	6.30	6.14	0.79	4.72	2.36	1.50	2.36	4.4 lb
SVA 25 - 40	mm	12	199	208	212	222	26	155	80	50	70	3.0 kg
SVA (1 - 1½)	in.	0.47	7.83	8.19	8.35	8.74	1.02	6.10	3.15	1.97	2.76	6.6 lb

SVA-S, Socket weld

SVA 32	mm	12	200	209	212	222	27.4	155	80	50	70	3.0 kg
SVA (1¼)	in.	0.47	7.87	8.23	8.35	8.74	1.08	6.10	3.15	1.97	2.76	6.6 lb
SVA 40	mm	12	204	213	212	222	31.0	155	80	50	70	3.0 kg
SVA (1½)	in.	0.47	8.03	8.39	8.35	8.74	1.22	6.10	3.15	1.97	2.76	6.6 lb

SVA-L

SVA 15 - 20	mm	63	188	184	202	198	20	120	60	38	60	2.0 kg
SVA (½ - ¾)	in.	2.48	7.40	7.24	7.95	7.80	0.79	4.72	2.36	1.50	2.36	4.4 lb
SVA 25 - 40	mm	74	243	252	256	265	26	155	80	50	70	3.0 kg
SVA (1 - 1½)	in.	2.91	9.57	9.92	10.08	10.43	1.02	6.10	3.15	1.97	2.76	6.6 lb

SVA-L, Socket weld

SVA 32	mm	74	244	253	256	265	27.4	155	80	50	70	3.0 kg
SVA (1¼)	in.	2.91	9.61	9.96	10.08	10.43	1.08	6.10	3.15	1.97	2.76	6.6 lb
SVA 40	mm	74	248	257	256	265	31.0	155	80	50	70	3.0 kg
SVA (1½)	in.	2.91	9.76	10.12	10.08	10.43	1.22	6.10	3.15	1.97	2.76	6.6 lb

Specified weights are approximate values only.

Dimensions and weights

SVA 50 - 65 (2 - 2½ in.) in angleway version with cap / hand wheel

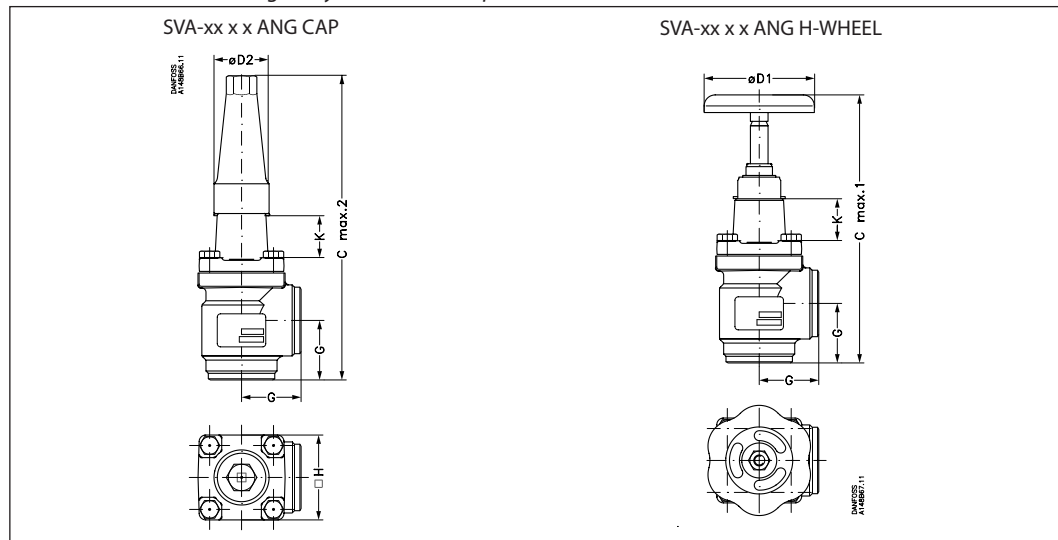

Valve size	K	C _{max.1}	C _{max.2}	G	ØD ₁	ØD ₂	□H	Weight
------------	---	--------------------	--------------------	---	-----------------	-----------------	----	--------

SVA-S

SVA 50	mm	70	284	315	60	100	50	77	3.2 kg
SVA (2)	in.	2.76	11.18	12.40	2.36	3.94	1.97	3.03	7.1 lb
SVA 65	mm	70	310	335	70	100	50	90	4.8 kg
SVA (2½)	in.	2.76	12.20	13.19	2.76	3.94	1.97	3.54	10.6 lb

SVA-S, Socket weld

SVA 50	mm	70	289	320	65	100	50	77	4.1 kg
SVA (2)	in.	2.76	11.38	12.60	2.56	3.94	1.97	3.03	9.0 lb

Specified weights are approximate values only.

Dimensions and weights

SVA 50 - 65 (2 - 2½ in.) in straightway version with cap / hand wheel

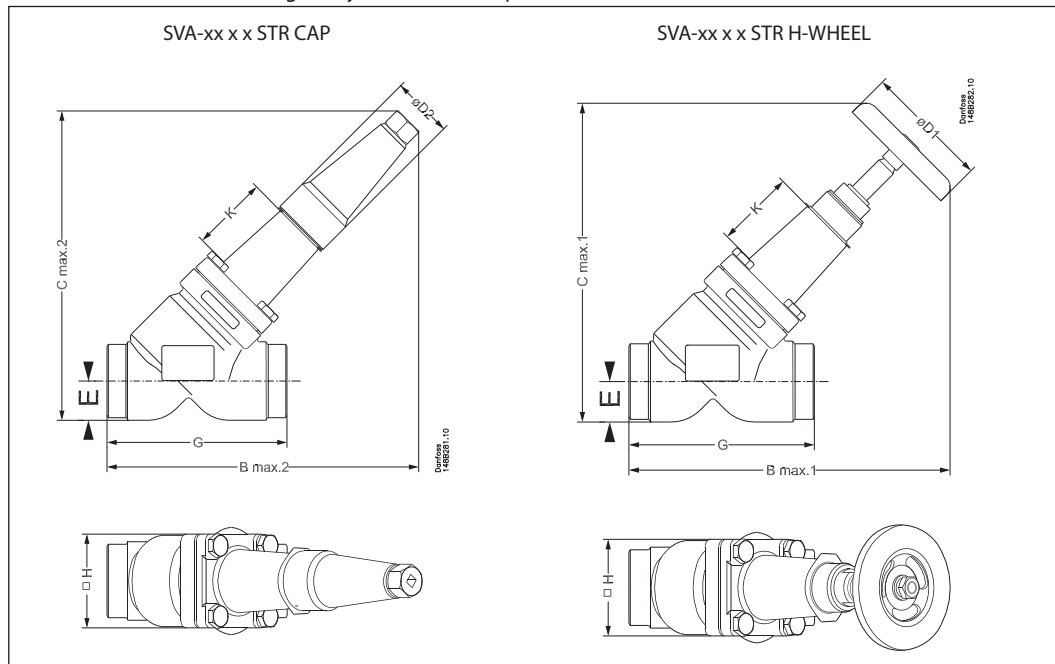

Valve size		K	B _{max.1}	B _{max.2}	C _{max.1}	C _{max.2}	E	G	ØD ₁	ØD ₂	□H	Weight
SVA-S												
SVA 50	mm	70	259	259	257	257	32	148	100	50	77	4.2 kg
SVA (2)	in.	2.76	10.20	10.20	10.12	10.12	1.26	5.83	3.94	1.97	3.03	9.3 lb
SVA 65	mm	70	284	280	284	280	40	176	100	50	90	6.3 kg
SVA (2½)	in.	2.76	11.18	11.02	11.18	11.02	1.57	6.93	3.94	1.97	3.54	13.9 lb
SVA-S, Socket weld												
SVA 50	mm	70	266	266	261	261	37	162	100	50	77	5.1 kg
SVA (2)	in.	2.76	10.47	10.47	10.28	10.28	1.26	6.38	3.94	1.97	3.03	11.2 lb

Specified weights are approximate values only.

Dimensions and weights

SVA 80 - 200 (3 - 8 in.) angleyway version with cap / hand wheel

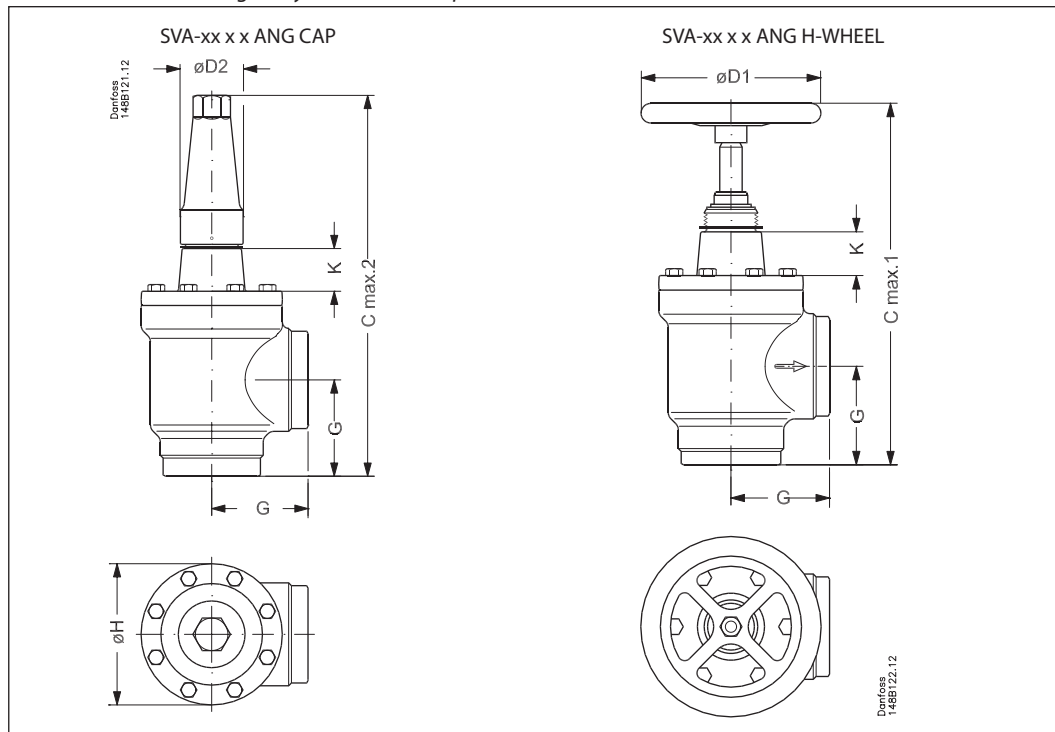

Valve size		K	C _{max.1}	C _{max.2}	G	ØD ₁	ØD ₂	ØH	Weight
SVA-S									
SVA 80	mm	76	373	388	90	200	58	129	9.7 kg
SVA (3)	in.	3.00	14.69	15.28	3.54	7.87	2.28	5.08	21.4 lb
SVA 100	mm	90	432	437	106	250	58	156	15.3 kg
SVA (4)	in.	3.54	17.00	17.20	4.17	9.84	2.28	6.14	33.7 lb
SVA 125	mm	90	517	533	128	315	74	193	28.1 kg
SVA (5)	in.	3.54	20.35	20.98	5.04	12.40	2.91	7.60	61.9 lb
SVA 150	mm	90	564	568	145	315	74	219	39.7 kg
SVA (6)	in.	3.54	22.20	22.36	5.71	12.40	2.91	8.62	87.5 lb
SVA 200	mm	90	677	678	180	400	86	276	79.5 kg
SVA (8)	in.	3.54	26.63	26.69	7.09	15.75	3.39	10.87	175.3 lb

Specified weights are approximate values only.

Dimensions and weights SVA 80 - 200 (3 - 8 in.) straightway version with cap / hand wheel

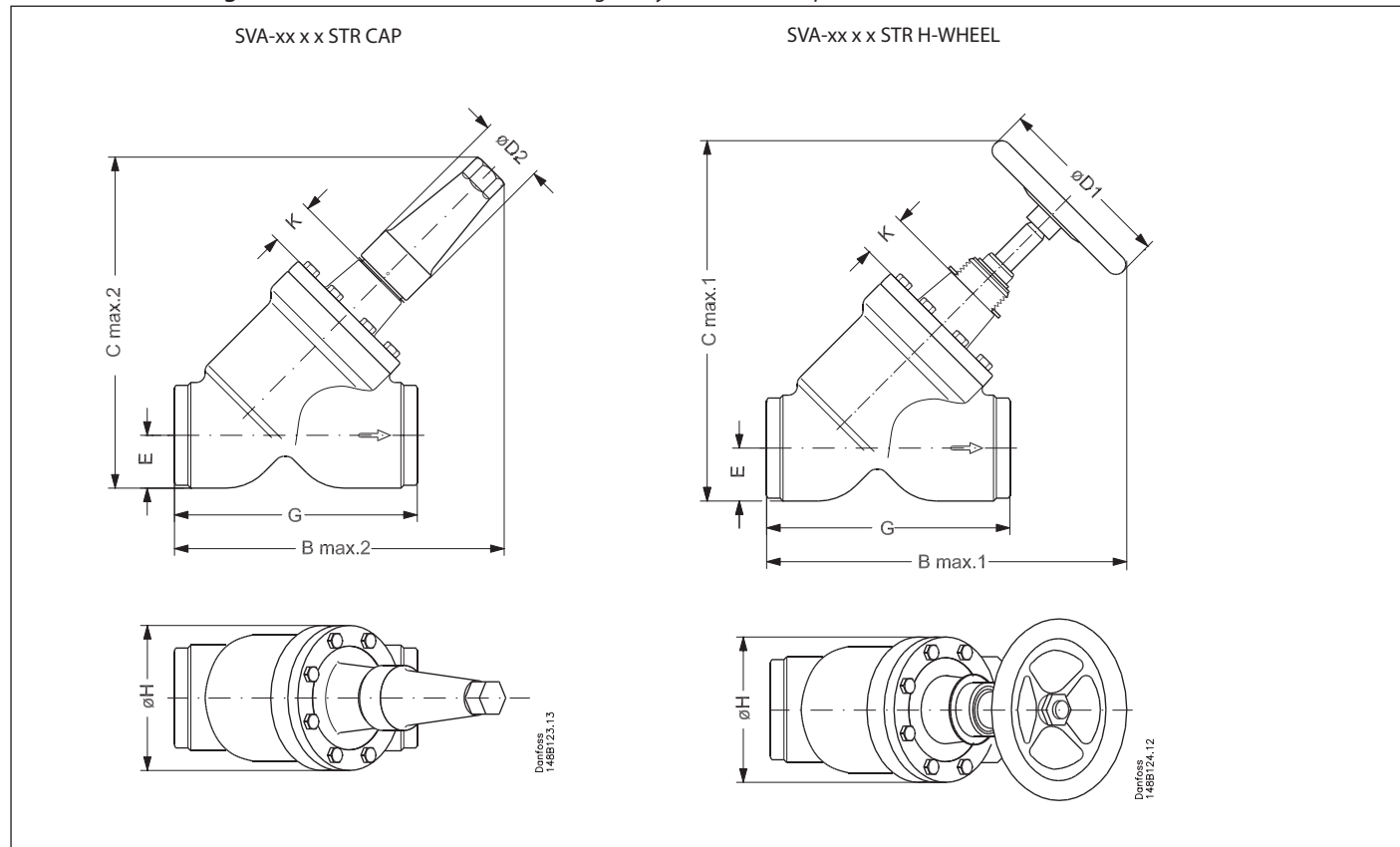

Valve size		K	B _{max.1}	B _{max.2}	C _{max.1}	C _{max.2}	E	G	ØD ₁	ØD ₂	ØH	Weight
SVA-S												
SVA 80	mm	76	365	321	367	322	48	216	200	58	129	10.9 kg
SVA (3)	in.	3.00	14.37	12.64	14.45	12.72	1.89	8.50	7.87	2.28	5.08	24.0 lb
SVA 100	mm	90	435	367	443	375	60	264	250	58	156	18.2 kg
SVA (4)	in.	3.54	17.13	14.45	17.44	14.76	2.36	10.39	9.84	2.28	6.14	40.1 lb
SVA 125	mm	90	526	444	538	456	74	322	315	74	193	32.8 kg
SVA (5)	in.	3.54	20.71	17.48	21.18	17.95	2.91	12.68	12.40	2.91	7.60	72.3 lb
SVA 150	mm	90	572	483	594	505	91	370	315	74	219	60.0 kg
SVA (6)	in.	3.54	22.52	19.02	23.39	19.88	3.58	14.57	12.40	2.91	8.62	132.3 lb
SVA 200	mm	90	692	579	726	613	117	464	400	86	276	111.5 kg
SVA (8)	in.	3.54	27.24	22.80	28.58	24.13	4.61	18.27	15.75	3.39	10.87	245.8 lb

Specified weights are approximate values only.

Data sheet | Shut-off valves, types SVA-S and SVA-L

Ordering

Available connection sizes

SVA-S:

The **S** means **Standard** bonnet length (sizes from DN50 to DN200 are insulation friendly)

SVA-L:

The **L** means **Long** bonnet length (insulation friendly)

Size		SVA-S	SVA-L
mm	in.		
6	¼	x	
10	⅜	x	
15	½	x	x
20	¾	x	x
25	1	x	x
32	1¼	x	x
40	1½	x	x
50	2	x	
65	2½	x	
80	3	x	
100	4	x	
125	5	x	
150	6	x	
200	8	x	

Please note that the type codes only serve to identify the valves, some of which may not form part of the standard product range. For further information please contact your local Danfoss Sales Company.

Type codes

Valve type	SVA	Shut-off valve
Nominal size in mm (valve size measured on the connection diameter)	6 10 15 20 25 32 40 50 65 80 100 125 150 200	DN 6 (¼)
		DN 10 (⅜)
		DN 15 (½)
		DN 20 (¾)
		DN 25 (1)
		DN 32 (1¼)
		DN 40 (1½)
		DN 50 (2)
		DN 65 (2½)
		DN 80 (3)
		DN 100 (4)
		DN 125 (5)
		DN 150 (6)
		DN 200 (8)
Connections	A SOC FPT	Butt-weld connection: ANSI B 36.10 schedule 80, DN 15 - 40 (½ - 1½ in.) Butt-weld connection: ANSI B 36.10 schedule 40, DN 50 - 200 (2 - 8 in.) Socket weld: ANSI B 16.11 Female Pipe Thread NPT: ANSI/ASME B 1.20.1
Valve housing	ANG STR	Angle flow Straight flow
Other equipment	H-WHEEL CAP	Hand wheel Cap

Important!

Where products need to be certified according to specific certification societies or where higher pressures are required, the relevant information should be included at the time of order.

Ordering SVA-S complete valves

Important!

Where products need to be certified according to specific certification societies or where higher pressures are required, the relevant information should be included at the time of order.

SVA-S Angleway

Size		Type	MWP		Code number
mm	in.		bar	psi	

Butt-weld ANSI (B 36.10 Schedule 80)

6	¼	SVA-S 6 A ANG H-WHEEL	52	754	148B5020
6	¼	SVA-S 6 A ANG CAP	52	754	148B5021
10	¾	SVA-S 10 A ANG H-WHEEL	52	754	148B5120
10	¾	SVA-S 10 A ANG CAP	52	754	148B5121
15	½	SVA-S 15 A ANG H-WHEEL	52	754	148B5220
15	½	SVA-S 15 A ANG CAP	52	754	148B5221
20	¾	SVA-S 20 A ANG H-WHEEL	52	754	148B5320
20	¾	SVA-S 20 A ANG CAP	52	754	148B5321
25	1	SVA-S 25 A ANG H-WHEEL	52	754	148B5420
25	1	SVA-S 25 A ANG CAP	52	754	148B5421
32	1¼	SVA-S 32 A ANG H-WHEEL	52	754	148B5520
32	1¼	SVA-S 32 A ANG CAP	52	754	148B5521
40	1½	SVA-S 40 A ANG H-WHEEL	52	754	148B5620
40	1½	SVA-S 40 A ANG CAP	52	754	148B5621

Butt-weld ANSI (B 36.10 Schedule 40)

50	2	SVA-S 50 A ANG H-WHEEL	52	754	148B5720
50	2	SVA-S 50 A ANG CAP	52	754	148B5721
65	2½	SVA-S 65 A ANG H-WHEEL	52	754	148B5820
65	2½	SVA-S 65 A ANG CAP	52	754	148B5821
80	3	SVA-S 80 A ANG H-WHEEL	52	754	148B5920
80	3	SVA-S 80 A ANG CAP	52	754	148B5921
100	4	SVA-S 100 A ANG H-WHEEL	52	754	148B6020
100	4	SVA-S 100 A ANG CAP	52	754	148B6021
125	5	SVA-S 125 A ANG H-WHEEL	52	754	148B6120
125	5	SVA-S 125 A ANG CAP	52	754	148B6121
150	6	SVA-S 150 A ANG H-WHEEL	52	754	148B6220
150	6	SVA-S 150 A ANG CAP	52	754	148B6221
200	8	SVA-S 200 A ANG H-WHEEL	52	754	148B6320
200	8	SVA-S 200 A ANG CAP	52	754	148B6321

Socket welding ANSI (B 16.11)

15	½	SVA-S 15 SOC ANG H-WHEEL	52	754	148B5222
15	½	SVA-S 15 SOC ANG CAP	52	754	148B5223
20	¾	SVA-S 20 SOC ANG H-WHEEL	52	754	148B5322
20	¾	SVA-S 20 SOC ANG CAP	52	754	148B5323
25	1	SVA-S 25 SOC ANG H-WHEEL	52	754	148B5422
25	1	SVA-S 25 SOC ANG CAP	52	754	148B5423
32	1¼	SVA-S 32 SOC ANG H-WHEEL	52	754	148B5522
32	1¼	SVA-S 32 SOC ANG CAP	52	754	148B5523
40	1½	SVA-S 40 SOC ANG H-WHEEL	52	754	148B5622
40	1½	SVA-S 40 SOC ANG CAP	52	754	148B5623
50	2	SVA-S 50 SOC ANG H-WHEEL	52	754	148B5722
50	2	SVA-S 50 SOC ANG CAP	52	754	148B5723

FPT inside pipe thread, NPT (ANSI/ASME B 1.20.1)

15	½	SVA-S 15 FPT ANG H-WHEEL	52	754	148B5224
15	½	SVA-S 15 FPT ANG CAP	52	754	148B5225
20	¾	SVA-S 20 FPT ANG H-WHEEL	52	754	148B5324
20	¾	SVA-S 20 FPT ANG CAP	52	754	148B5325
25	1	SVA-S 25 FPT ANG H-WHEEL	52	754	148B5424
25	1	SVA-S 25 FPT ANG CAP	52	754	148B5425
32	1¼	SVA-S 32 FPT ANG H-WHEEL	52	754	148B5524
32	1¼	SVA-S 32 FPT ANG CAP	52	754	148B5525

SVA-S Straightway

Size		Type	MWP		Code number
mm	in.		bar	psi	

Butt-weld ANSI (B 36.10 Schedule 80)

6	¼	SVA-S 6 A STR H-WHEEL	52	754	148B5030
6	¼	SVA-S 6 A STR CAP	52	754	148B5031
10	¾	SVA-S 10 A STR H-WHEEL	52	754	148B5130
10	¾	SVA-S 10 A STR CAP	52	754	148B5131
15	½	SVA-S 15 A STR H-WHEEL	52	754	148B5230
15	½	SVA-S 15 A STR CAP	52	754	148B5231
20	¾	SVA-S 20 A STR H-WHEEL	52	754	148B5330
20	¾	SVA-S 20 A STR CAP	52	754	148B5331
25	1	SVA-S 25 A STR H-WHEEL	52	754	148B5430
25	1	SVA-S 25 A STR CAP	52	754	148B5431
32	1¼	SVA-S 32 A STR H-WHEEL	52	754	148B5530
32	1¼	SVA-S 32 A STR CAP	52	754	148B5531
40	1½	SVA-S 40 A STR H-WHEEL	52	754	148B5630
40	1½	SVA-S 40 A STR CAP	52	754	148B5631

Butt-weld ANSI (B 36.10 Schedule 40)

50	2	SVA-S 50 A STR H-WHEEL	52	754	148B5730
50	2	SVA-S 50 A STR CAP	52	754	148B5731
65	2½	SVA-S 65 A STR H-WHEEL	52	754	148B5830
65	2½	SVA-S 65 A STR CAP	52	754	148B5831
80	3	SVA-S 80 A STR H-WHEEL	52	754	148B5930
80	3	SVA-S 80 A STR CAP	52	754	148B5931
100	4	SVA-S 100 A STR H-WHEEL	52	754	148B6030
100	4	SVA-S 100 A STR CAP	52	754	148B6031
125	5	SVA-S 125 A STR H-WHEEL	52	754	148B6130
125	5	SVA-S 125 A STR CAP	52	754	148B6131
150	6	SVA-S 150 A STR H-WHEEL	52	754	148B6230
150	6	SVA-S 150 A STR CAP	52	754	148B6231
200	8	SVA-S 200 A STR H-WHEEL	52	754	148B6330
200	8	SVA-S 200 A STR CAP	52	754	148B6331

Socket welding ANSI (B 16.11)

15	½	SVA-S 15 SOC STR H-WHEEL	52	754	148B5232
15	½	SVA-S 15 SOC STR CAP	52	754	148B5233
20	¾	SVA-S 20 SOC STR H-WHEEL	52	754	148B5332
20	¾	SVA-S 20 SOC STR CAP	52	754	148B5333
25	1	SVA-S 25 SOC STR H-WHEEL	52	754	148B5432
25	1	SVA-S 25 SOC STR CAP	52	754	148B5433
32	1¼	SVA-S 32 SOC STR H-WHEEL	52	754	148B5532
32	1¼	SVA-S 32 SOC STR CAP	52	754	148B5533
40	1½	SVA-S 40 SOC STR H-WHEEL	52	754	148B5632
40	1½	SVA-S 40 SOC STR CAP	52	754	148B5633
50	2	SVA-S 50 SOC STR H-WHEEL	52	754	148B5732
50	2	SVA-S 50 SOC STR CAP	52	754	148B5733

FPT inside pipe thread, NPT (ANSI/ASME B 1.20.1)

15	½	SVA-S 15 FPT STR H-WHEEL	52	754	148B5234
15	½	SVA-S 15 FPT STR CAP	52	754	148B5235
20	¾	SVA-S 20 FPT STR H-WHEEL	52	754	148B5334
20	¾	SVA-S 20 FPT STR CAP	52	754	148B5335
25	1	SVA-S 25 FPT STR H-WHEEL	52	754	148B5434
25	1	SVA-S 25 FPT STR CAP	52	754	148B5435
32	1¼	SVA-S 32 FPT STR H-WHEEL	52	754	148B5534
32	1¼	SVA-S 32 FPT STR CAP	52	754	148B5535

ANG = Angleway
 STR = Straightway
 CAP = Cap
 H-WHEEL = Hand wheel

Data sheet | Shut-off valves, types SVA-S and SVA-L

Ordering SVA-L complete valves

Example:
SVA-L 20 DIN angleway with hand wheel = **148B5340**

Important!

Where products need to be certified according to specific certification societies or where higher pressures are required, the relevant information should be included at the time of order.

ANG = Angleway
STR = Straightway

CAP = Cap
H-WHEEL = Hand wheel

SVA-L Angleway

Size		Type	MWP		Code number
mm	in.		bar	psi	

Butt-weld ANSI (B 36.10 Schedule 80)

15	½	SVA-L 15 A ANG H-WHEEL	52	754	148B5260
15	½	SVA-L 15 A ANG CAP	52	754	148B5261
20	¾	SVA-L 20 A ANG H-WHEEL	52	754	148B5360
20	¾	SVA-L 20 A ANG CAP	52	754	148B5361
25	1	SVA-L 25 A ANG H-WHEEL	52	754	148B5460
25	1	SVA-L 25 A ANG CAP	52	754	148B5461
32	1¼	SVA-L 32 A ANG H-WHEEL	52	754	148B5560
32	1¼	SVA-L 32 A ANG CAP	52	754	148B5561
40	1½	SVA-L 40 A ANG H-WHEEL	52	754	148B5660
40	1½	SVA-L 40 A ANG CAP	52	754	148B5661

Socket welding ANSI (B 16.11)

15	½	SVA-L 15 SOC ANG H-WHEEL	52	754	148B5262
15	½	SVA-L 15 SOC ANG CAP	52	754	148B5263
20	¾	SVA-L 20 SOC ANG H-WHEEL	52	754	148B5362
20	¾	SVA-L 20 SOC ANG CAP	52	754	148B5363
25	1	SVA-L 25 SOC ANG H-WHEEL	52	754	148B5462
25	1	SVA-L 25 SOC ANG CAP	52	754	148B5463
32	1¼	SVA-L 32 SOC ANG H-WHEEL	52	754	148B5562
32	1¼	SVA-L 32 SOC ANG CAP	52	754	148B5563
40	1½	SVA-L 40 SOC ANG H-WHEEL	52	754	148B5662
40	1½	SVA-L 40 SOC ANG CAP	52	754	148B5663

FPT inside pipe thread, NPT (ANSI/ASME B 1.20.1)

15	½	SVA-L 15 FPT ANG H-WHEEL	52	754	148B5264
15	½	SVA-L 15 FPT ANG CAP	52	754	148B5265
20	¾	SVA-L 20 FPT ANG H-WHEEL	52	754	148B5364
20	¾	SVA-L 20 FPT ANG CAP	52	754	148B5365
25	1	SVA-L 25 FPT ANG H-WHEEL	52	754	148B5464
25	1	SVA-L 25 FPT ANG CAP	52	754	148B5465
32	1¼	SVA-L 32 FPT ANG H-WHEEL	52	754	148B5564
32	1¼	SVA-L 32 FPT ANG CAP	52	754	148B5565

SVA-L Straightway

Size		Type	MWP		Code number
mm	in.		bar	psi	

Butt-weld ANSI (B 36.10 Schedule 80)

15	½	SVA-L 15 A STR H-WHEEL	52	754	148B5270
15	½	SVA-L 15 A STR CAP	52	754	148B5271
20	¾	SVA-L 20 A STR H-WHEEL	52	754	148B5370
20	¾	SVA-L 20 A STR CAP	52	754	148B5371
25	1	SVA-L 25 A STR H-WHEEL	52	754	148B5470
25	1	SVA-L 25 A STR CAP	52	754	148B5471
32	1¼	SVA-L 32 A STR H-WHEEL	52	754	148B5570
32	1¼	SVA-L 32 A STR CAP	52	754	148B5571
40	1½	SVA-L 40 A STR H-WHEEL	52	754	148B5670
40	1½	SVA-L 40 A STR CAP	52	754	148B5671

Socket welding ANSI (B 16.11)

15	½	SVA-L 15 SOC STR H-WHEEL	52	754	148B5272
15	½	SVA-L 15 SOC STR CAP	52	754	148B5273
20	¾	SVA-L 20 SOC STR H-WHEEL	52	754	148B5372
20	¾	SVA-L 20 SOC STR CAP	52	754	148B5373
25	1	SVA-L 25 SOC STR H-WHEEL	52	754	148B5472
25	1	SVA-L 25 SOC STR CAP	52	754	148B5473
32	1¼	SVA-L 32 SOC STR H-WHEEL	52	754	148B5572
32	1¼	SVA-L 32 SOC STR CAP	52	754	148B5573
40	1½	SVA-L 40 SOC STR H-WHEEL	52	754	148B5672
40	1½	SVA-L 40 SOC STR CAP	52	754	148B5673

FPT inside pipe thread, NPT (ANSI/ASME B 1.20.1)

15	½	SVA-L 15 FPT STR H-WHEEL	52	754	148B5274
15	½	SVA-L 15 FPT STR CAP	52	754	148B5275
20	¾	SVA-L 20 FPT STR H-WHEEL	52	754	148B5374
20	¾	SVA-L 20 FPT STR CAP	52	754	148B5375
25	1	SVA-L 25 FPT STR H-WHEEL	52	754	148B5474
25	1	SVA-L 25 FPT STR CAP	52	754	148B5475
32	1¼	SVA-L 32 FPT STR H-WHEEL	52	754	148B5574
32	1¼	SVA-L 32 FPT STR CAP	52	754	148B5575

Data sheet | Shut-off valves, types SVA-S and SVA-L

Ordering SVA-S from the parts programme

Example
(select from
table 1 and 2)

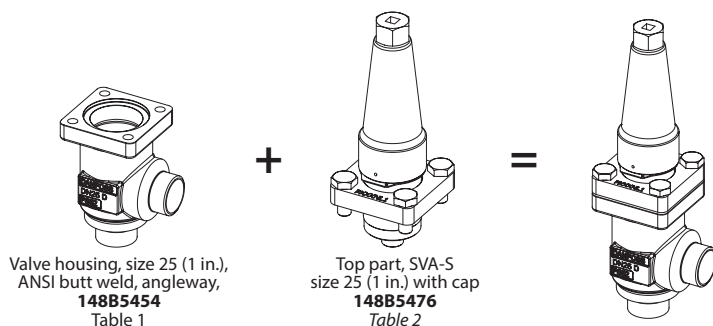
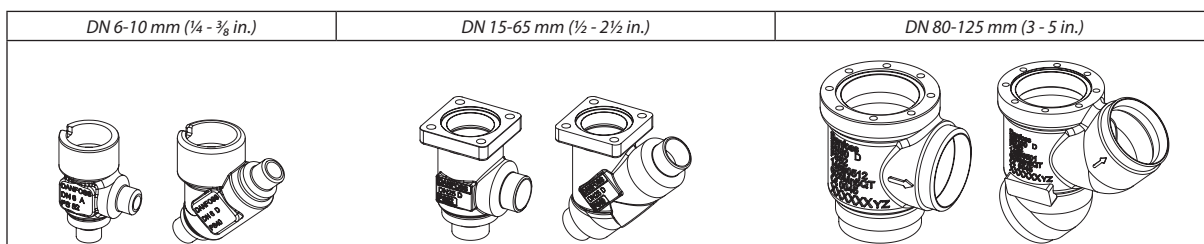

Table 1
SVL valve housings w/different connections



Please note:
Not all sizes available for SVA-L - see table 2.

Sizes [DN]		Valve Housing SVL					
		ANSI-Butt weld		SOC		FPT	
mm	in.	ANG	STR	ANG	STR	ANG	STR
6	1/4	148B5004	148B5005				
10	3/8	148B5124	148B5125				
15	1/2	148B5254	148B5255	148B5256	148B5257	148B5258	148B5259
20	3/4	148B5354	148B5355	148B5356	148B5357	148B5358	148B5359
25	1	148B5454	148B5455	148B5456	148B5457	148B5458	148B5459
32	1 1/4	148B5578	148B5579	148B5580	148B5581	148B5582	148B5583
40	1 1/2	148B5654	148B5655	148B5656	148B5657		
50	2	148B5743	148B5744	148B5745	148B5746		
65	2 1/2	148B5818	148B5819				
80	3	148B5914	148B5915				
100	4	148B6016	148B6017				
125	5	148B6114	148B6115				

Table 2
SVA complete top part including gaskets and bolts

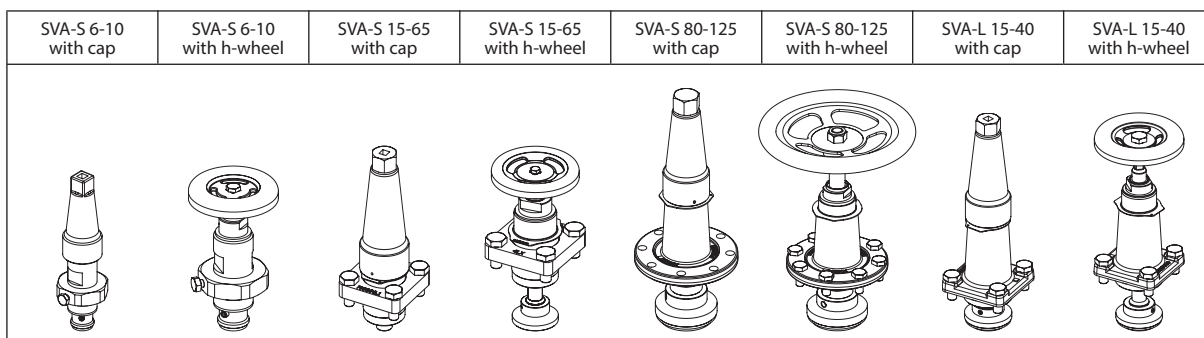

Sizes [DN]		Complete top part			
mm	in.	SVA-S CAP	SVA-S H-WHEEL	SVA-L CAP	SVA-L H-WHEEL
6	1/4				
10	3/8	148B5013	148B5014		
15	1/2				
20	3/4	148B5276	148B5277	148B5278	148B5279
25	1				
32	1 1/4	148B5476	148B5477	148B5478	148B5479
40	1 1/2				
50	2	148B5728	148B5729		
65	2 1/2	148B5822	148B5823		
80	3	148B5916	148B5917		
100	4	148B6012	148B6018		
125	5	148B6116	148B6117		

ENGINEERING
TOMORROW



Danfoss can accept no responsibility for possible errors in catalogues, brochures and other printed material. Danfoss reserves the right to alter its products without notice. This also applies to products already on order provided that such alterations can be made without subsequential changes being necessary in specifications already agreed. All trademarks in this material are property of the respective companies. Danfoss and the Danfoss logotype are trademarks of Danfoss A/S. All rights reserved.