



3/2-Way Zone-Drain-Valves VDHT 2E, VDHT 15E and VDHT 15EC





General information

The 3/2 way valves have in particular been designed for applications in high-pressure humidification and adiabatic cooling systems. Each valve has an IN, OUT and DRAIN port.

When the valve is not in operation the connection between IN and OUT is closed while the connection between OUT and DRAIN stays open. This allows to instantaneously relief the pressure at shut down from the application, typically a nozzle branch, to prevent the nozzles from dripping. If desired, the nozzle branch can be entirely drained after shut down to avoid bacterial growth. Furthermore, each valve has its individual properties to match exactly the specific needs in size and functionality

All of our valves are made of stainless steel (AISI 304) and are suitable for potable and technical water. They have an extremely long service life for at least one million operations and are even then very easy to service.

Inline valves are available with European BSP thread (G-thread) and American National Pipe Thread (NPT). For the VDHT 15EC Danfoss offers a wide range of single and multiple manifolds.

The enclosure rating is IP 67, including any standard solenoid coil. A large variety of coils for various supply voltages is available for all our valves.

Generally
(continued)

The VDHT 2E is a small valve for minor flow rates up to 2 litres per minute (0.52 GPM). It is a direct operated type of valve with one NO and NC armature.

The VDHT 2E requires 2 coils activated by a common signal (ie. 24 V AC).

It is suitable for systems with many zones with few nozzles and is a very cost effective solution.



The VDHT 15E is a medium size single inline valve for flow rates up to 15 litres per minute (4 gpm to the zone). It is based on the latest valve technology, comprising a piston type NC valve and a NO pilot stage in one housing. The NO part has a relative small orifice, so it cannot drain a big volume very fast.

It covers a very wide flow range already starting from 1 litre per minute (0.26 gpm) and is the ideal solution instead of using 2 separate valves (1 NC and 1 NO). The VDHT 15E requires 2 solenoids activated by a common signal (i.e. 24 V AC).



The VDHT 15EC 3/2 is the Cetop 3 variant of the VDHT 15E, by means that connections are made through a valve block or multiple valve manifold. In multiple valve applications up to 5 valves can be installed on a common manifold side by side, saving time, space and plumbing effort.



HVAC Block

The HVAC blocks are especially designed for in-duct applications where an additional flush valve installed on the block allows to flush the system for improved hygiene. 3 different types are available for 1, 2 or 3 VDHT 15EC plus one additional 2/2-way VDHT flush valve. The blocks comprise one common connection for the pressure line from the pump station and one common drain port for pressure relief and flushing. For each discharge an outlet port is available. The HVAC block is a very cost efficient solution i.e. in in-duct systems with 6-step valve control. Each VDH/VDHT valve is operated by two coils (NC and NO), while the flush valve is a single coil NC valve. Please also refer to the list of code numbers on page 5.

Picture fully equipped blocks 1+1 and 2+1

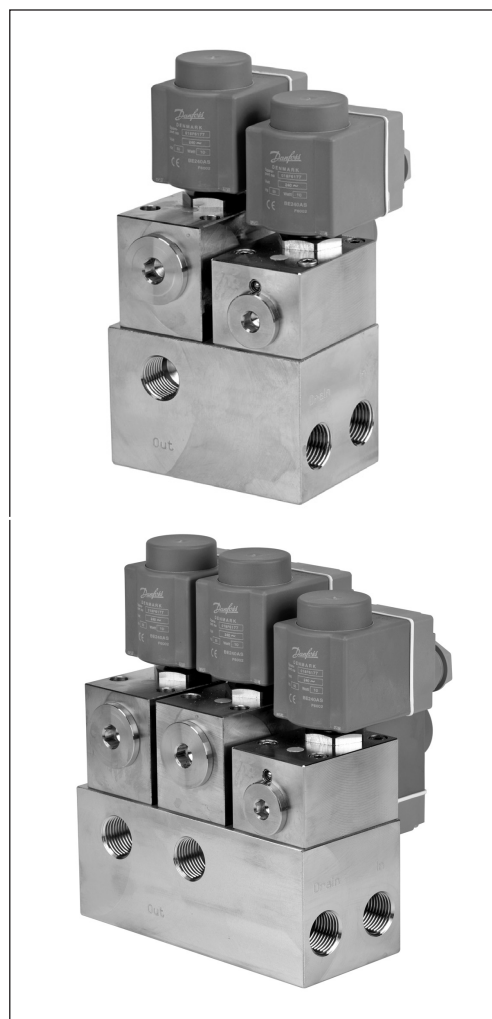

Sub-base valve manifolds

Danfoss offers sub-base manifolds for installing 3, 4 or 5 VDH/VDHT 3/2 way valves side by side. Just as the HVAC blocks, the sub-base manifolds represent a very cost efficient solution, saving significantly on time, space and plumbing effort, as the number of connections is minimized.



Picture sub-base manifolds and simple inline block

Both multiple valve concepts are very service friendly as the valves can individually be detached from the manifold for service within a few minutes. VDHT 15EC valves can be service while installed on the block.

All manifolds can be connected from both sides, allowing a high level of flexibility for placing them i.e. directly on the pumping station. For a spare block position Danfoss offers a bind plate to cover the connections when not in use.

The HVAC block and the multiple valve manifolds are interconnectable, i.e. in systems with more than 5 valves. Danfoss recommends bonded seal fittings for all connections.

3/2-way principle

Solenoid coil(s) de-energized

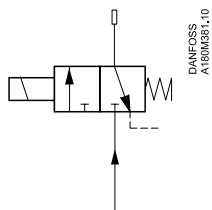

Solenoid coils energized

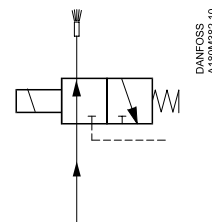

Soft-Charge principle

Both coils de-energized

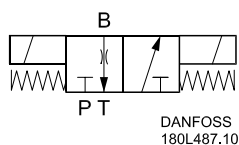

DANFOSS
180L487.10

P-port (IN) closed,
B- and T-port connected
(OUT and DRAIN), application
pipe drained

NC coil energized only

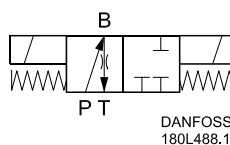

DANFOSS
180L488.10

P-, T-and B-port
(IN, OUT and DRAIN)
connected; flow partially
to application and drain

Both coils energized

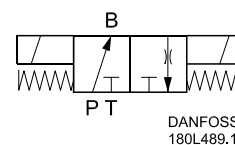

DANFOSS
180L489.10

P- and B-port (IN and
OUT) connected, T-port
(DRAIN) closed, full flow
to application

Technical Data

	VDHT 2E	VDHT 15E	VDHT 15 EC
Max. continuous inlet pressure in bar/psi	80/1150	140/2000	140/2000
Max. peak inlet pressure in bar/psi	100/1450	160/2300	160/2300
Min. operation pressure at IN port in bar/psi	1	2/29	2/29
Drain opening pressure in bar/psi	80/1150	80/1150	80/1150
Max. flow IN to OUT in l/min/gpm	2/0.52	15/4	15/4
Min. flow IN to OUT in l/min/gpm	0	1/0.26	1/0.26
Max. flow to DRAIN in l/min/gpm	2/0.52	5/1.3	5/1.3
Opening/closing time in ms	250	250	250
Max. water temperature in °C/°F	50/122	50/122	50/122
Weight without coil(s) in kg/lbs	1.3/2.8	1.5/3.5	1.5/3.5

Pressure losses at different flows

VDHT 2E

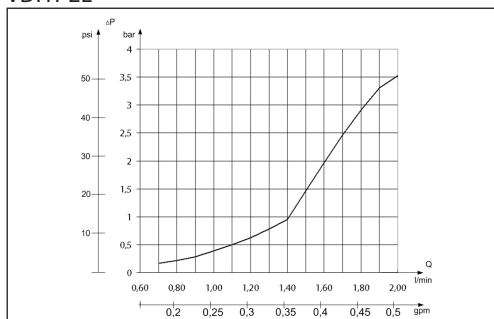

VDHT 15E3/2, VDHT 15 EC3/2

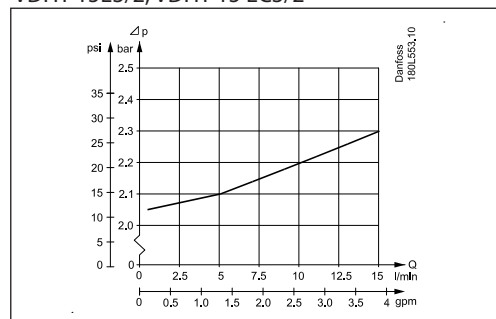

Code Numbers

Valves and blocks	Code number
VDHT 2E 3 x G 1/4"	180L0298
VDHT 2E 3 x 1/4 NPT	180L1017
VDHT 15E G 3/8", 3/8", 1/4"	180L0173
VDHT 15E 3 x 3/8 NPT	180L0174
VDHT 15EC (Cetop 3)	180L0240
HVAC block 1+1 (1 valve + flush valve)	180L0181
HVAC block 2+1 (2 valves + flush valve)	180L0182
HVAC block 3+1 (3 valves + flush valve)	180L0183
VDHT 30EC NC 2/2-way (flush valve)	180L0096
Sub-base manifold for 3 VDHT 15EC	180L0261
Sub-base manifold for 4 VDHT 15EC	180L0262
Sub-base manifold for 5 VDHT 15EC	180L0263
Blind plate (to cover spare position)	180L0079

Coils	Supply Voltage	Power	Code number
Standard clip-on coils NC+NO	24 V/50 Hz	10 W	018F7920
	220V/50 Hz	10 W	018F7921
	240V/50 Hz	10 W	018F7924
	24 V/60 Hz	10 W	018F7922
	110 V/50/60 Hz	10 W	018F7923
	220 V/60 Hz	10 W	018F7925
	240 V/60 Hz	10 W	018F7926
UL Recognized (UR) coils NC+NO	24 V/50/60 Hz	14 W	018F7907
	110 V/50/60 Hz	14 W	018F7909
	208-240 V 50/60 Hz	14 W	018F7908
Plug for UR coils with DIN spade	all voltages		180Z0183

ATEX - consult the document "Solenoid valves intended for use in ATEX classified documents" 521B1101

Spare parts	Pos.no. included from exploded view drawing	Service instruction	Code number
Armature kit NO for VDHT	2, 3	180R9142	180L5010
Armature kit NO for VDH	2, 5	180R9142	180L5010
Armature kit NC for VDHT	1, 3	180R9035	180L5002
Armature kit NC for VDH	1, 5	180R9035	180L5002
Piston kit for VDHT 15 E	9, 10	180R9062	180Z0015
Piston kit for VDH 30 EC (NC+NO)	10, 14	180R9033	180L5005
Orifice kit VDHT NC (1,0 mm)	4, 6	180R9161	180Z0098
Orifice kit VDHT NO (1,4 mm)	5, 6	180R9161	180Z0097
Orifice kit VDHT 2E NC and NO (1,4 mm)	5, 6	180R9161	180Z0097

Water Quality, Filtration

All types of valves are suitable for operation with potable water or technical water such as reverse osmosis water, de-mineralised water or de-ionised water.
The water must be filtered to a minimum of 10 µm absolute.

Installation

The VDHT 2E and VDHT 15E can be mounted self-supporting by the pipes or can be mounted with bolts to any surface (see below).

The VDHT 15EC is installed according to the Cetop standard.
4 bolts and O-rings for block mounting are supplied with the valve.

Dimensions, mm (in)

VDHT 2E3/2

180M5089
Danfoss

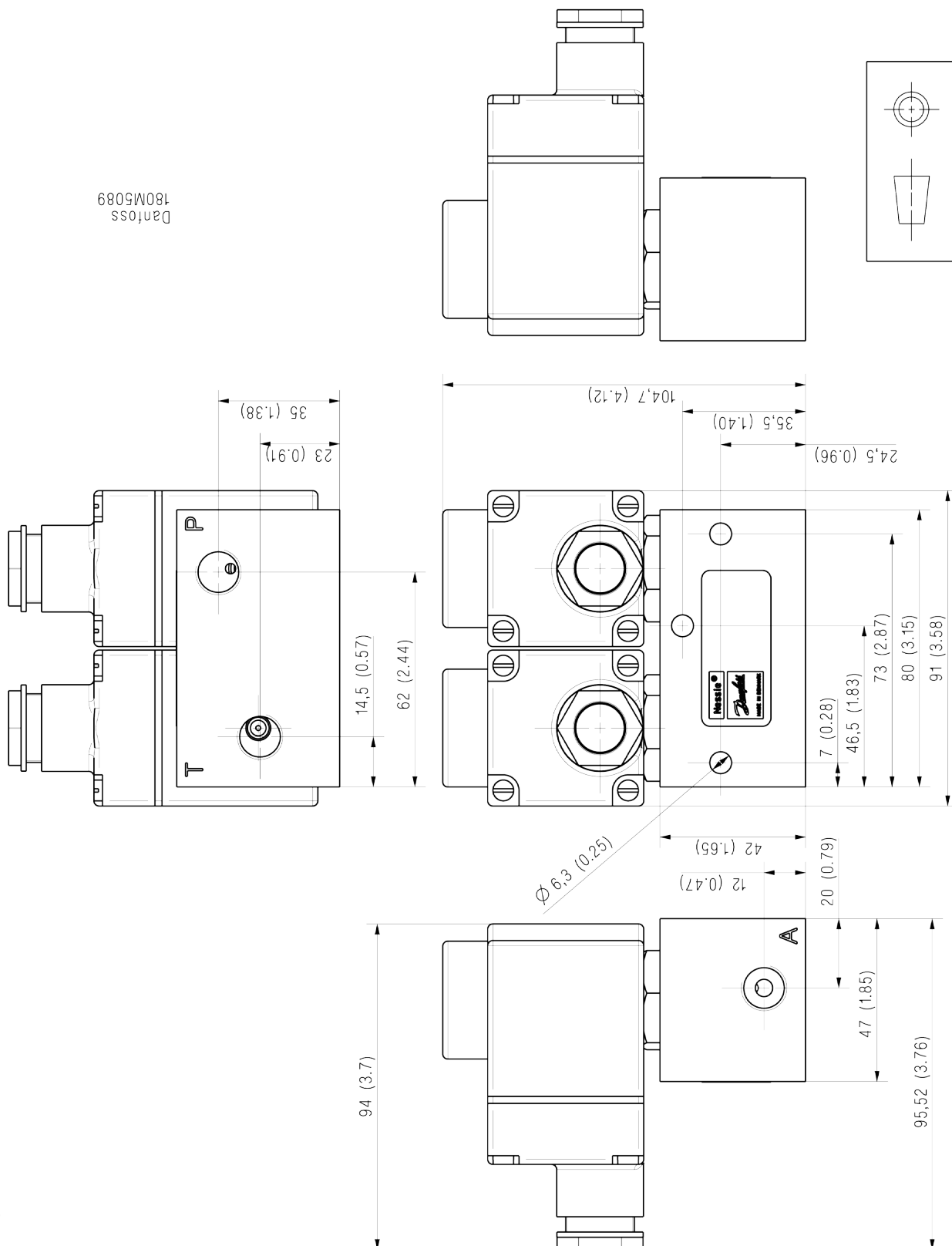

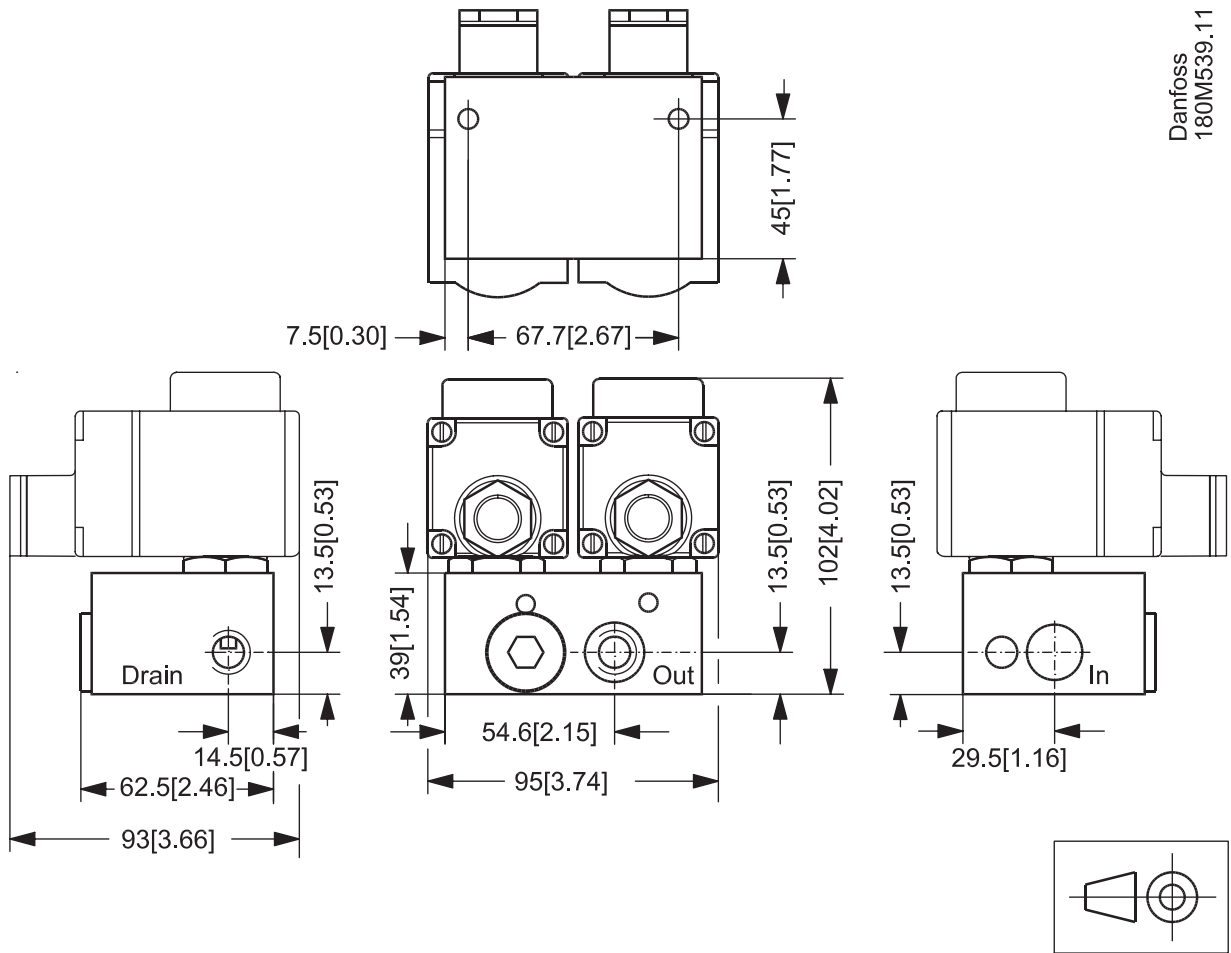

Dimensions, mm (in)

VDHT 15EC

Danfoss
180M577.10

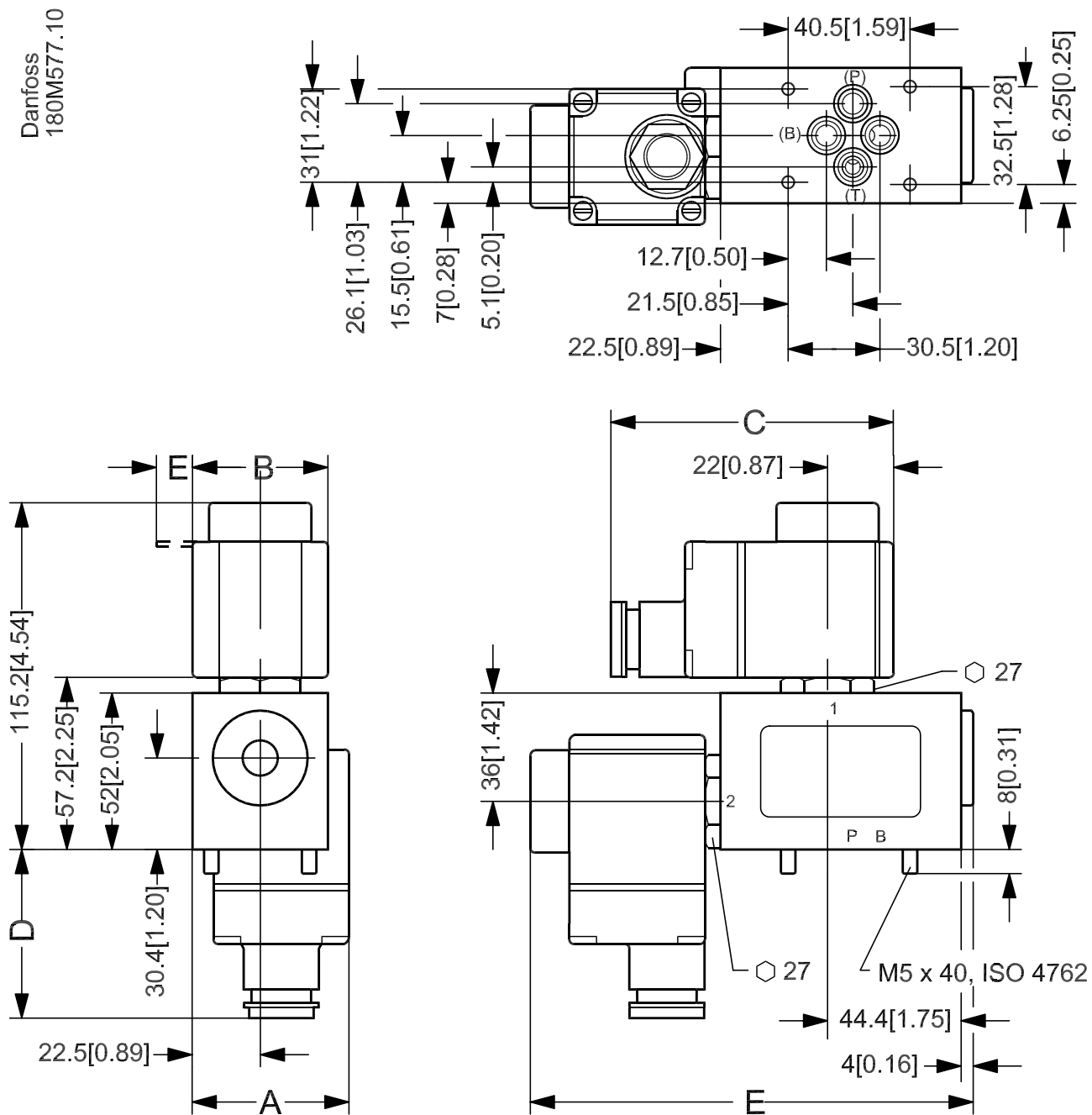

	A	B	C	D	E
NC/NO	52[2.05]	46[1.81]	93[3.66]	72[2.83]	
EEX	63[2.48]	68[2.68]	125[4.92]	95[3.74]	12[0.47]

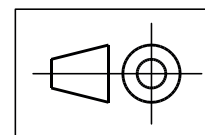

Seal kit spare part VDHT F

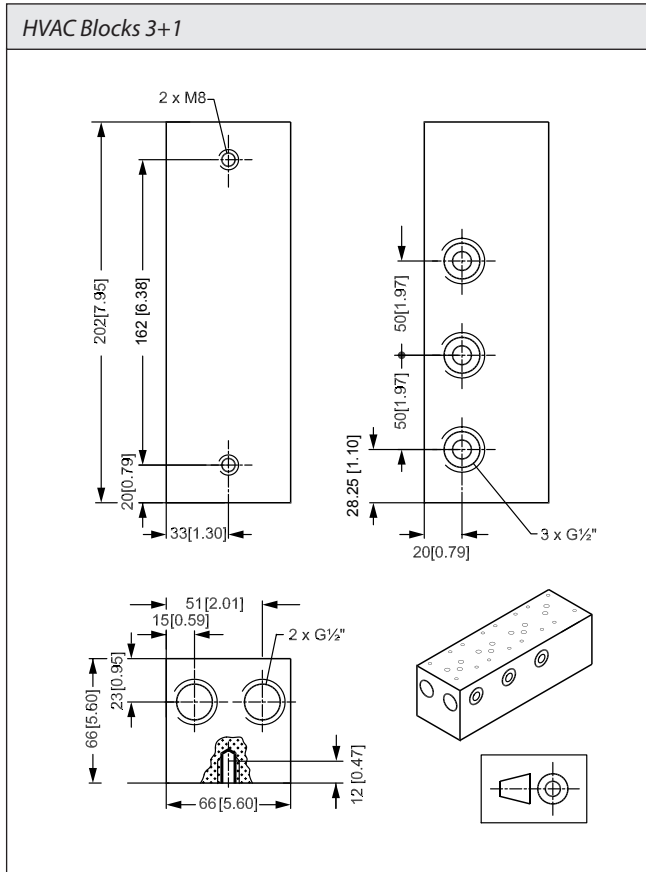
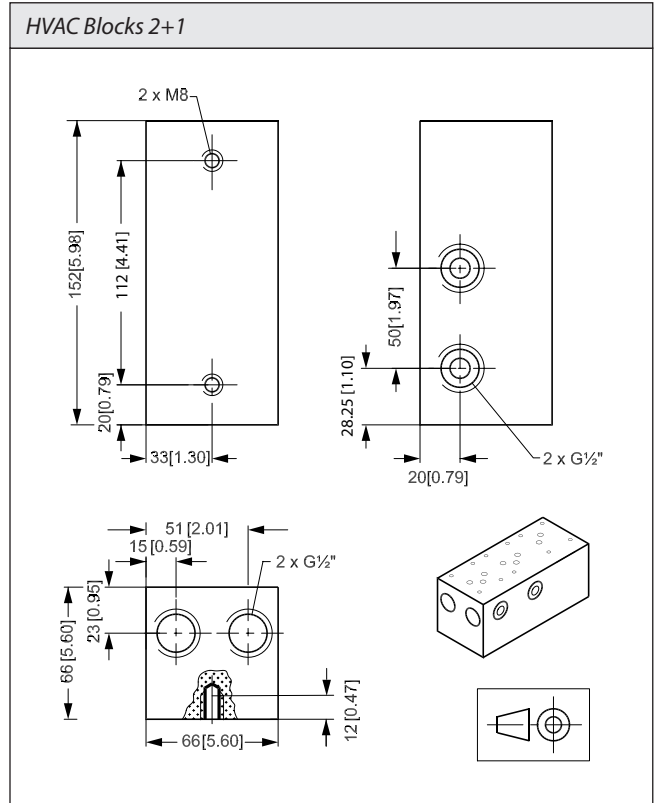
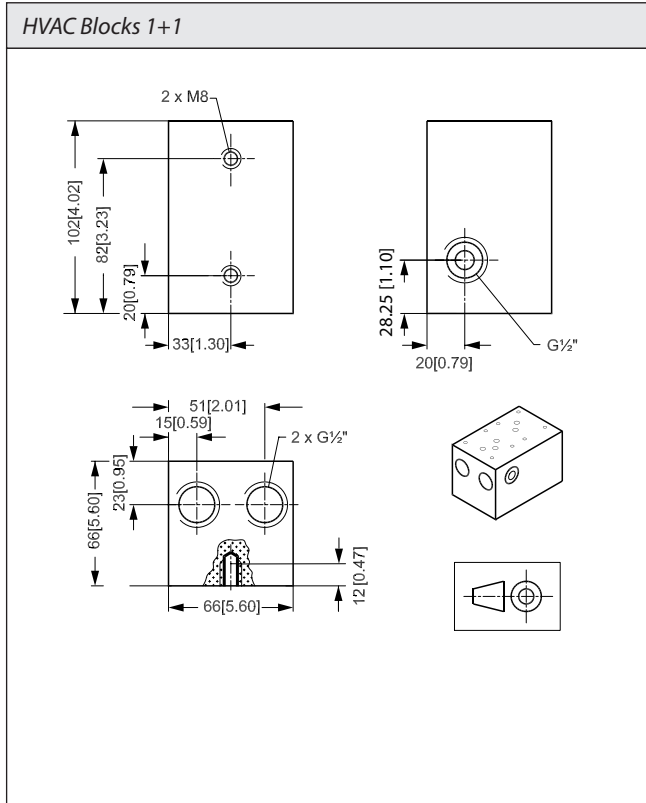

Dimensions, mm (in)
- Manifolds

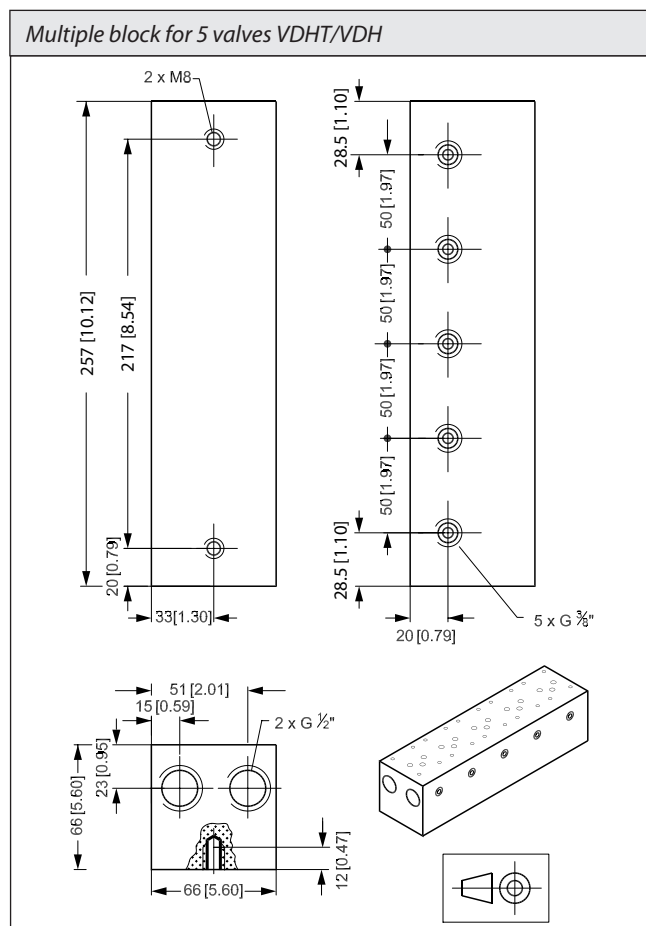
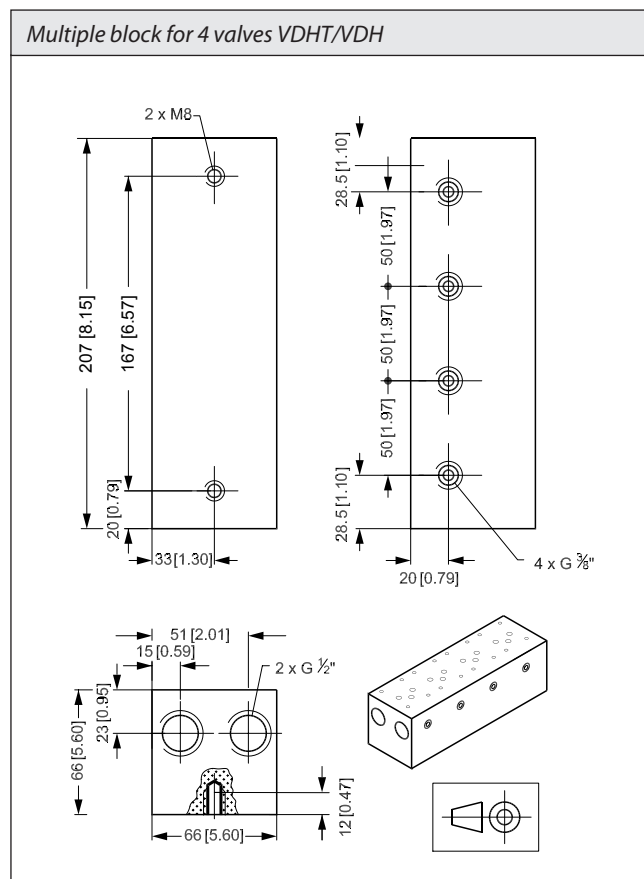
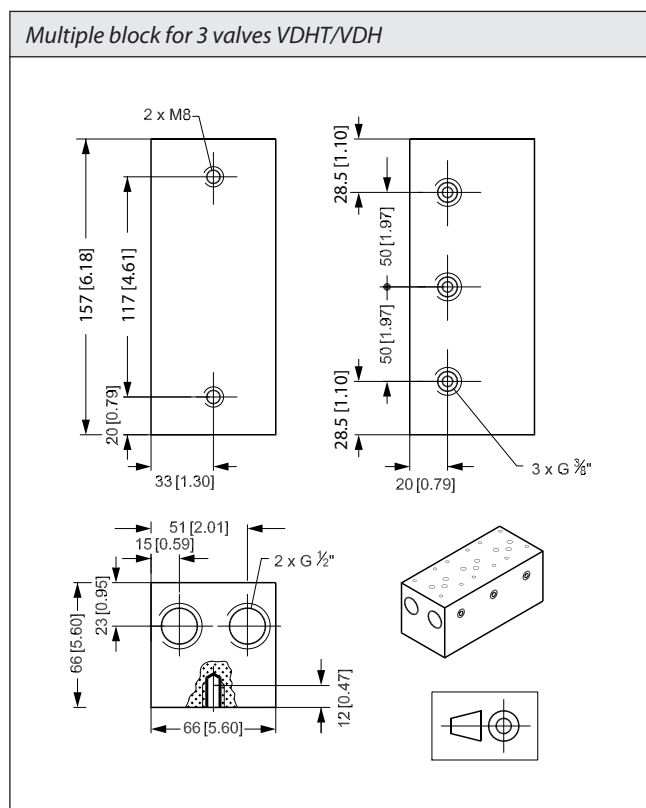

Danfoss can accept no responsibility for possible errors in catalogues, brochures and other printed material. Danfoss reserves the right to alter its products without notice. This also applies to products already on order provided that such alterations can be made without consequential changes being necessary in specifications already agreed. All trademarks in this material are property of the respective companies. Danfoss and the Danfoss logotype are trademarks of Danfoss A/S. All rights reserved.



Danfoss A/S
High Pressure Pumps
Nordborgvej 81, D25
6430 Nordborg
Tel.: +45 7488 5280
Fax: +45 7445 3831
danfoss.high-pressurepumps.com