

Data sheet

Solenoid valve VDHT Standard BSP (British Standard Pipe)



Contents

1.	Picture overview	3
2.	Introduction	4
3.	VDHT valve selection overview	4
4.	Overview single valves	5
5.	Overview single valves	6
6.	Overview block valves	7
7.	Overview coils and accessories	8
8.	VDH 2E 1/4 Drawing Spare parts	9
9.	VDHT 1/4 E Drawing Spare parts	10
10.	VDHT 3/8 E, VDHT 1/2 E Drawing Spare parts	11
11.	VDHT 3/8 EA, VDHT 1/2 EA Drawing Spare parts	12
12.	VDHT 3/4 ED N, VDHT 1 ED N Drawing Spare parts	13
13.	VDHT 3/4 EA, VDHT 1 EA Drawing Spare parts	14
14.	VDHT 3/4 EA N, VDHT 1 EA N Drawing Spare parts	15
15.	VDHT 30 EC Drawing	16
16.	Block for CETOP 3 valves	17
17.	VDHT B Spare parts	18
18.	VDHT BL N Drawings	19
19.	VDHT BL N Spare parts	20
20.	VDHT BLM Drawings	21
21.	VDHT BLM Spare parts	22
22.	Overview spare parts	23
23.	Pressure losses INLET to OUTLET	24

1. Picture overview

<p>VDHT for small flows</p> 	
<p>VDH 2E 1/4</p>	<p>VDHT 1/4 E</p>
<p>VDHT for small and medium flows</p> 	
<p>VDHT 3/8 E VDHT 1/2 E</p>	<p>VDHT 3/8 EA VDHT 1/2 EA</p>
<p>VDHT for big flows</p> 	
<p>VDHT 3/4 ED VDHT 1 ED</p>	<p>VDHT 3/4 EA VDHT 1 EA</p>
<p>VDHT manifold mounted valve</p> 	
<p>VDHT 30 EC G 3/8 / Cetop 3 manifold</p>	
<p>VDHT integrated valve blocks</p> 	
<p>VDHT B 2-5 Input G 1/2 / G 3/4 Output G 1/2</p>	<p>VDHT BL 2-4 Input G 3/4 / G 1 Output G 3/4 / G 1</p>
<p>VDHT manual bypass</p> 	
<p>VDHT EAM</p>	<p>VDHT BLM 2-4</p>

2. Introduction

The VDHT valve series are designed for several applications in neutral media compatible with the sealing and O-ring materials used. Typical media are water, cleaning fluids and light heating oil.

The valves are used in several applications: car wash systems, stationary high pressure cleaning, mobile cleaning vehicles and dust bindings systems, ect.

Function

The directional valves are pilot operated ON/OFF – seat valves electrically activated by a coil.

Features

- Corrosion resistant
- Easy-to-clean
- Reliability
- Dirt tolerant, max. sieve (strainer) width 200 µm or better
- High temperature-resistant
- Robust design prevents leakage
- High coil density IP67 (NEMA 4X)
- Possible to get a compact and simple block solution (Integrated valve block)

Versions

The valve housing, blocks and manifolds are made of stainless steel AISI 304 (W.No. 1.4301), and the piston of stainless steel AISI 316 (W.No. 1.4401). Standard valves are delivered with PTFE piston and FKM as seal material and FPM O-rings.

VDHT inline valves are available with a number of mounting possibilities, flow direction, port size: ¼, ⅜, ½, ¾ and 1" BSP and more - defining the following designation. The VDHT valves are also available with NPT thread.

VDHT integrated valve blocks provide a space and cost-saving solution in applications where valves are placed next to each other. Furthermore, integrated valves blocks provide a pressure loss reduction.

3. VDHT valve selection overview

E	Straight flow direction	BL N	Block version large / New version stroke
EA	Angular flow direction	DF	2-Stage dampening system opening stroke
EC 3	Cetop 3 manifold	F	Flange port input
ED	Displaced flow direction	NC	Normally closed
HP	High pressure variant	NO	Normally opened
B	Block version small	BSP	British Standard Pipe
BL	Block version large	NPT	National Pipe Thread
BLM	Block version manual bypass	SAE	Unified national fine thread
N	New version slimline		

Temperature

- Medium temperature: 2–90 °C (35.6–194 °F)
- Ambient temperature: 2–80 °C (35.6–176 °F) depending on the coil specification
- Storage temperature: -40–80 °C (-40–176 °F) Provided that the valve is drained from fluid and stored “plugged”.

General

P_{in} > P_{out}	For correct functioning of the VDHT valves, always ensure the inlet pressure to be higher than the outlet pressure
Pilot flow	The VDHT pilot operated poppet type (armature + poppet) always needs min. 1 l/min. (0.26 gpm) flow to ensure correct functioning
Viscosity	Max viscosity of fluid: 45mm ² /s. Remark fluid viscosity has influence on pressure drop and opening/closing time of the VDHT valves.

4. Overview single valves
2/2-way solenoid valve, type VDH 2E 1/4

Opening / Closing time NC (at Qnom) 100–200 ms / 100–200 ms



Description	Code no.	Q nom l/min. (gpm)	p max barg (psig)	T max °C (°F)	Conne- ction	Operating pressure/ barg (psig)	Weight excl. coil kg (lbs)	Piston Ø mm	Orifice kit
VDH 2E 1/4 NC 1,4 BSP	180L0018	2 (0.5)	100 (1450)	90 (194)	G 1/4	0.0	0.5 (1.1)	–	4
VDH 2E 1/4 NO 1,4 BSP	180L0019	2 (0.5)	90 (1300)	90 (194)	G 1/4	0.0	0.5 (1.1)	–	4
VDH 2E 1/4 NC 3,5 BSP	180L1018	5 (0.7)	30 (435)	90 (194)	G 1/4	0.0	0.5 (1.1)	–	5

2/2 - way solenoid valve, type VDHT 1/4 E

Opening / Closing time NC (at Qnom) 100–200 ms / 100–200 ms



Description	Code no.	Q nom l/min. (gpm)	p max barg (psig)	T max °C (°F)	Conne- ction	Operating pressure/ barg (psig)	Weight excl. coil kg (lbs)	Piston Ø mm	Orifice kit
VDHT 1/4 E NC BSP	180L0241	15 (4.0)	100 (1450)	90 (194)	G 1/4	0.3 (4.5)	0.6 (1.3)	ø11.9	1
VDHT 1/4 E NO BSP	180L0242	15 (4.0)	100 (1450)	90 (194)	G 1/4	0.3 (4.5)	0.6 (1.3)	ø11.9	1

2/2 - way solenoid valve, type VDHT 3/8 E and 1/2 E

Opening / Closing time NC (at Qnom) G 3/8: 100–125 ms / 200–300 ms, G 1/2: 120–140 ms / 200–300 ms



Description	Code no.	Q nom l/min. (gpm)	p max barg (psig)	T max °C (°F)	Conne- ction	Operating pressure/ barg (psig)	Weight excl. coil kg (lbs)	Piston Ø mm	Orifice kit
VDHT 3/8 E NC BSP	180L0092	30 (8)	160 (2400)	90 (194)	G 3/8	3.5 (51)	1.2 (2.6)	ø18.1	1
VDHT 3/8 E NO BSP	180L0093	30 (8)	160 (2400)	90 (194)	G 3/8	3.5 (51)	1.2 (2.6)	ø18.1	1
VDHT 3/8 E HP NC BSP	180L0178	30 (8)	210 (3000)	90 (194)	G 3/8	3.5 (51)	1.2 (2.6)	ø18.1	1
VDHT 1/2 E NC BSP	180L0094	60 (16)	160 (2400)	90 (194)	G 1/2	3.5 (51)	1.2 (2.6)	ø18.1	1
VDHT 1/2 E NO BSP	180L0095	60 (16)	160 (2400)	90 (194)	G 1/2	3.5 (51)	1.2 (2.6)	ø18.1	1
VDHT 1/2 E HP NC BSP	180L0126	60 (16)	210 (3000)	90 (194)	G 1/2	3.5 (51)	1.2 (2.6)	ø18.1	1

2/2 - way solenoid valve, type VDHT 3/8 EA, 1/2 EA, 3/4 EA and 1 EA

 Opening / Closing time NC (at Qnom) G 3/8: 100–125 ms / 200–300 ms, G 1/2: 120–140 ms / 200–300 ms,
 G 3/4: 500–700 ms / 900–1200 ms, G1: 500–900 ms / 1200–2000 ms

Description	Code no.	Q nom l/min. (gpm)	p max barg (psig)	T max °C (°F)	Conne- ction	Operating pressure/ barg (psig)	Weight excl. coil kg (lbs)	Piston Ø mm	Orifice kit
VDHT 3/8 EA NC BSP	180L0100	30 (8)	160 (2400)	90 (194)	G 3/8	3.5 (51)	1.2 (2.6)	ø18.1	1
VDHT 3/8 EA NO BSP	180L0101	30 (8)	160 (2400)	90 (194)	G 3/8	3.5 (51)	1.2 (2.6)	ø18.1	1
VDHT 1/2 EA NC BSP	180L0188	60 (16)	160 (2400)	90 (194)	G 1/2	3.5 (51)	1.2 (2.6)	ø18.1	1
VDHT 1/2 EA NO BSP	180L0103	60 (16)	160 (2400)	90 (194)	G 1/2	3.5 (51)	1.2 (2.6)	ø18.1	1
VDHT 1/2 EA HP NC BSP	180L0234	60 (16)	210 (3000)	90 (194)	G 1/2	3.5 (51)	1.2 (2.6)	ø18.1	1
VDHT 3/4-1/2 EA NC BSP	180L0090	60 (16)	140 (2000)	90 (194)	G 3/4 - G 1/2	3.5 (51)	2.3 (5.0)	ø18.1	1
VDHT 3/4 EA NC BSP N	180L1015	120 (32)	140 (2000)	90 (194)	G 3/4	3.5 (51)	2.3 (5.0)	ø35.1 N	1
VDHT 1 EA NC BSP N	180L1023	150 (40)	140 (2000)	90 (194)	G 1	3.5 (51)	2.3 (5.0)	ø35.1 N	1

5. Overview single valves **2/2 - way solenoid block valve, type VDHT 3/4 ED and 1 ED**

Opening / Closing time NC (at Qnom) G 3/4: 500–700 ms / 900–1200 ms, G 1: 500–900 ms / 1200–2000 ms



Description	Code no.	Q nom l/min (gpm)	p max barg (psig)	T max °C (°F)	Connection	Operating pressure/ barg (psig)	Weight excl. coil kg (lbs)	Piston Ø mm	Orifice kit
VDHT 3/4 ED NC BSP N	180L1012	120 (32)	140 (2030)	90 (194)	G 3/4	3.5 (51)	2.4 (5.3)	ø35.1 N	1
VDHT 3/4 ED HP NC BSP N	180L1030	120 (32)	210 (3000)	90 (194)	G 3/4	3.5 (51)	2.5 (5.5)	ø35.1 N	1
VDHT 1 ED NC BSP N	180L1022	150 (40)	140 (2030)	90 (194)	G 1	3.5 (51)	2.4 (5.3)	ø35.1 N	1
VDHT 1 ED NO BSP N	180L1014	150 (40)	140 (2030)	90 (194)	G 1	3.5 (51)	2.4 (5.3)	ø35.1 N	1

2/2 - way cetop 3 valves , type VDHT 30 EC

Opening / Closing time NC (at Qnom) 100–125 ms / 200–300 ms



Description	Code no.	Q nom l/min (gpm)	p max barg (psig)	T max °C (°F)	Connection	Operating pressure/ barg (psig)	Weight excl. coil kg (lbs)	Piston Ø mm	Orifice kit
VDHT 30 EC3 NC BSP	180L0096	30 (8)	160 (2400)	90 (194)	Cetop 3	3.5 (51)	1.0 (2.2)	ø18.1	1
VDHT 30 EC3 NO BSP	180L0097	30 (8)	160 (2400)	90 (194)	Cetop 3	3.5 (51)	1.0 (2.2)	ø18.1	1

Block for Cetop 3 valves



Description	Code no.	Q nom l/min (gpm)	p max barg (psig)	T max °C (°F)	Connection	Operating pressure/ barg (psig)	Weight kg (lbs)	Piston Ø mm	Orifice kit
Block for 2 Pe CETOP 3 valve	180L0062	30 (8)	160 (2400)	90 (194)	G 3/8	3.5 (51)	1.8 (3.9)	–	–
Block for 3 Pe CETOP 3 valve	180L0063	30 (8)	160 (2400)	90 (194)	G 3/8	3.5 (51)	2.6 (5.7)	–	–
Block for 4 Pe CETOP 3 valve	180L0064	30 (8)	160 (2400)	90 (194)	G 3/8	3.5 (51)	3.4 (7.5)	–	–

6. Overview block valves

2/2 - way integrated valve block, type VDHT B 2-5



Description	Code no.	Q nom l/min (gpm)	p max barg (psig)	T max °C (°F)	Connection	Operating pressure/ barg (psig)	Weight excl. coil kg (lbs)	Piston Ø mm	Orifice kit
VDHT B2 1/2 NC BSP	180L0270	60 (16)	160 (2400)	90 (194)	G 1/2 - G 1/2	3.5 (51)	3.7 (8.2)	ø18.1	1
VDHT B2 1/2 NC-NO BSP	180L0258	60 (16)	160 (2400)	90 (194)	G 1/2 - G 1/2	3.5 (51)	3.7 (8.2)	ø18.1	1
VDHT B2 3/4-1/2 NC BSP	180L0124	60 (16)	160 (2400)	90 (194)	G 3/4 - G 1/2	3.5 (51)	3.7 (8.2)	ø18.1	1
VDHT B3 3/4-1/2 NC BSP	180L0088	60 (16)	160 (2400)	90 (194)	G 3/4 - G 1/2	3.5 (51)	5.5 (12.1)	ø18.1	1
VDHT B4 3/4-1/2 NC BSP	180L0123	60 (16)	160 (2400)	90 (194)	G 3/4 - G 1/2	3.5 (51)	7.4 (16.3)	ø18.1	1
VDHT B5 3/4-1/2 NC BSP	180L0091	60 (16)	160 (2400)	90 (194)	G 3/4 - G 1/2	3.5 (51)	9.3 (20.5)	ø18.1	1

2/2 - way integrated valve block, type VDHT BL 2-4



Description	Code no.	Q nom l/min (gpm)	p max barg (psig)	T max °C (°F)	Connection	Operating pressure/ barg (psig)	Weight excl. coil kg (lbs)	Piston Ø mm	Orifice kit
VDHT BL2 3/4 NC BSP N	180L1003	120 (32)	140 (2030)	90 (194)	G 3/4 - G 3/4	3.5 (51)	4.8 (10.5)	ø35.1 N	1
VDHT BL2 HP 3/4 NC BSP N	180L1027	120 (32)	210 (3000)	90 (194)	G 3/4 - G 3/4	3.5 (51)	4.8 (10.5)	ø35.1 N	1
VDHT BL2 3/4 NC-NO BSP N	180L1024	120 (32)	140 (2030)	90 (194)	G 3/4 - G 3/4	3.5 (51)	4.8 (10.5)	ø35.1 N	1
VDHT BL2 1 NC BSP N	180L1002	150 (40)	140 (2030)	90 (194)	G 1 - G 1	3.5 (51)	4.8 (10.5)	ø35.1 N	1
VDHT BL2S 3/4 NC BSP N	180L1000	120 (32)	140 (2030)	90 (194)	G 3/4 - G 3/4	3.5 (51)	4.8 (10.5)	ø35.1 N	1
VDHT BL3 3/4 NC BSP N	180L1025	120 (32)	140 (2030)	90 (194)	G 3/4 - G 3/4	3.5 (51)	8.3 (18.2)	ø35.1 N	1
VDHT BL3 HP 3/4 NC BSP N	180L1028	120 (32)	210 (3000)	90 (194)	G 3/4 - G 3/4	3.5 (51)	8.3 (18.2)	ø35.1 N	1
VDHT BL3 1 NC BSP N	180L1011	150 (40)	140 (2030)	90 (194)	G 1 - G 1	3.5 (51)	8.3 (18.2)	ø35.1 N	1
VDHT BL4 1 NC BSP N	180L1016	150 (40)	140 (2030)	90 (194)	G 1 - G 1	3.5 (51)	9.7 (21.4)	ø35.1 N	1
VDHT BL4 HP 1 NC BSP N	180L1029	150 (40)	210 (3000)	90 (194)	G 1 - G 1	3.5 (51)	9.7 (21.4)	ø35.1 N	1

2/2-way solenoid block valve, type VDHT with manual bypass



Description	Code no.	Q nom l/min (gpm)	p max barg (psig)	T max °C (°F)	Connection	Operating pressure/ barg (psig)	Weight kg (lbs)	Piston Ø mm	Orifice kit
VDHT 3/4 EAM NC BSP	180L0122	120 (132)	140 (2030)	90 (194)	G 3/4	3.5 (51)	2.5 (5.5)	ø35.1	2
VDHT 1 EAM NC BSP	180L0110	150 (140)	140 (2030)	90 (194)	G 1	3.5 (51)	2.5 (5.5)	ø35.1	2
VDHT BLM1 3/4 NC BSP	180L0196	120 (132)	140 (2030)	90 (194)	G 3/4 - G 3/4	3.5 (51)	4.2 (9.2)	ø35.1	2
VDHT BLM2 3/4 NC BSP	180L0167	120 (132)	140 (2030)	90 (194)	G 3/4 - G 3/4	3.5 (51)	7.4 (16.3)	ø35.1	2
VDHT BLM2 1 NC BSP	180L0199	150 (140)	140 (2030)	90 (194)	G 1 - G 1	3.5 (51)	7.4 (16.3)	ø35.1	2
VDHT BLM3 3/4 NC BSP	180L0168	120 (132)	140 (2030)	90 (194)	G 3/4 - G 3/4	3.5 (51)	11.7 (25.7)	ø35.1	2
VDHT BLM4 3/4 NC BSP	180L0169	120 (132)	140 (2030)	90 (194)	G 3/4 - G 3/4	3.5 (51)	15.0 (33.0)	ø35.1	2

7. Overview coils and accessories



Description	Code no. HPP	Voltage	Power	Voltage tolerance	T max Ambiente °C (°F)	Connection	Enclosure	Weight kg (lbs)
Type BB / Without LED / for Hirschmann plug / excl. plug								
Coil 240V-50Hz-10W-IP65	018F7906	240V 50Hz	10W	+/- 10-15%	80 (176)	DIN 43650-A	IP65	0.2 (0.5)
Coil 24V-50Hz-10W-IP65	018F7905	24V 50Hz	10W		80 (176)	DIN 43650-A	IP65	0.2 (0.5)
Coil 240V-50Hz-10W-IP65	018F7928	24V DC	18W		+/- 10%	50 (122)	DIN 43650-A	IP65

Type BE / Without LED / incl. Terminal box									
Coil 240V-60Hz-10W-IP67	018F7926	240V 60Hz	10W	+/- 10-15%	80 (176)	Terminal box	IP67	0.3 (0.7)	
Coil 240V-50Hz-10W-IP67	018F7924	240V 50Hz	10W		80 (176)	Terminal box	IP67	0.3 (0.7)	
Coil 220-230V-50Hz-10W-IP67	018F7921	220-230 V 50 Hz	10W		80 (176)	Terminal box	IP67	0.3 (0.7)	
Coil 220-230V-50-60Hz-10W-IP67	018F7919	220-230 V 50-60Hz	10W		50 (122)	Terminal box	IP67	0.3 (0.7)	
Coil 220V-60Hz-10W-IP67	018F7925	220V 60Hz	10W		80 (176)	Terminal box	IP67	0.3 (0.7)	
Coil 200V-50-60Hz-10W-IP67	018F7929	200V 50/60Hz	10W		80 (176)	Terminal box	IP67	0.3 (0.7)	
Coil 110V-50-60Hz-10W-IP67	018F7923	110V 50-60Hz	10W		50 (122)	Terminal box	IP67	0.3 (0.7)	
Coil 24V-60Hz-10W-IP67	018F7922	24V 60Hz	10W		80 (176)	Terminal box	IP67	0.3 (0.7)	
Coil 24V-50Hz-10W-IP67	018F7920	24V 50Hz	10W		80 (176)	Terminal box	IP67	0.3 (0.7)	
Coil 42V-50Hz-10W-IP67	018F7927	42V 50Hz	10W		80 (176)	Terminal box	IP67	0.3 (0.7)	
Coil 24V-DC-18W-IP67	018F7914	24V DC	18W		+/- 10%	50 (122)	Terminal box	IP67	0.3 (0.7)
Coil 12V-DC-18W-IP67	018F7913	12V DC	18W		+/- 10%	50 (122)	Terminal box	IP67	0.3 (0.7)

Type BE / Without LED / for Hirschmann plug / prepare for terminal box								
Coil 200V-50-60Hz-10W-IP67	018F7918	200V 50/60 Hz	10W	+/- 10-15%	50 (122)	Terminal box	IP67	0.2 (0.5)
Coil 240V-50Hz-10W-IP67	018F7917	240V 50 Hz	10W		80 (176)	Terminal box	IP67	0.2 (0.5)
Coil 24V-DC-18W-IP67	018F7912	24V DC	18W	+/- 10%	50 (122)	Terminal box	IP67	0.3 (0.7)

Type BY / Without LED / for Hirschmann plug / excl. plug / UL Recognised								
Coil 208-240V-50-60Hz-14W-IP65-UL	018F7908	208-240V 50/60 Hz	14W	+/- 10-15%	50 (122)	DIN43650-A	IP65	0.2 (0.5)
Coil 110V-50-60Hz-14W-IP65-UL	018F7909	110V 50-60 Hz	14W		50 (122)	DIN43650-A	IP65	0.2 (0.5)
Coil 24V-50-60Hz-14W-IP65-UL	018F7907	24V 50-60 Hz	14W		50 (122)	DIN43650-A	IP65	0.2 (0.5)

Type BE / excl. LED / Incl. cable								
Coil 48V-50-60Hz-10W-IP67-4m cable	018F7915	48V 50Hz	10W	+/- 10-15%	80 (176)	4 mtr. cable	IP67	0.3 (0.7)

Type BO / Eex m II TA 94/9/EC (ATEX 100A) EN5001 & EN 50014 & EN50028								
Coil Eex m II TA 24V-DC-10W-IP67	180Z7993	24V DC	10W	+/- 10%	40 (104)	5 mtr. cable	IP67	0.5(1.3)

Connecting plug / Typ BY / excl. LED / for Hirschmann connection (DIN 43650-A) UL Recognised								
Plug EN175301-803 A PG11	180Z0183	-	Excl LED	-	90 (194)	BE-BB-BY	IP65	0.1 (0.3)

Connecting plug / Typ BY / incl. LED / for Hirschmann connection (DIN 43650-A) UL Recognised								
Plug EN175301-803 A 230V AC/DC LED	042N0265	230V AC	Incl LED	-	60 (140)	BE-BB-BY	IP65	0.1 (0.3)
Plug EN175301-803 A 24V AC/DC LED + PACK	042N0263	24V AC/DC	Incl LED	-	60 (140)	BE-BB-BY	IP65	0.1 (0.3)

Connection terminal box / Permanent magnet								
Terminal box excl. LED pack unit 100 Pe	018Z0279	-	Excl LED 100 PE	-	80 (176)	BE	IP67	0.1 (0.3)
Terminal box incl. LED 48-220V DC 24-250V-50Hz / only BE	018Z0089	48-220V DC24-250V 50/60 Hz	Incl. LED	-	80 (176)	BE	IP67	0.1 (0.3)
Permanent magnet	180Z0212	for testing	-	-	-	-	-	0.3 (0.7)

8. VDH 2E 1/4
Drawing
Spare parts

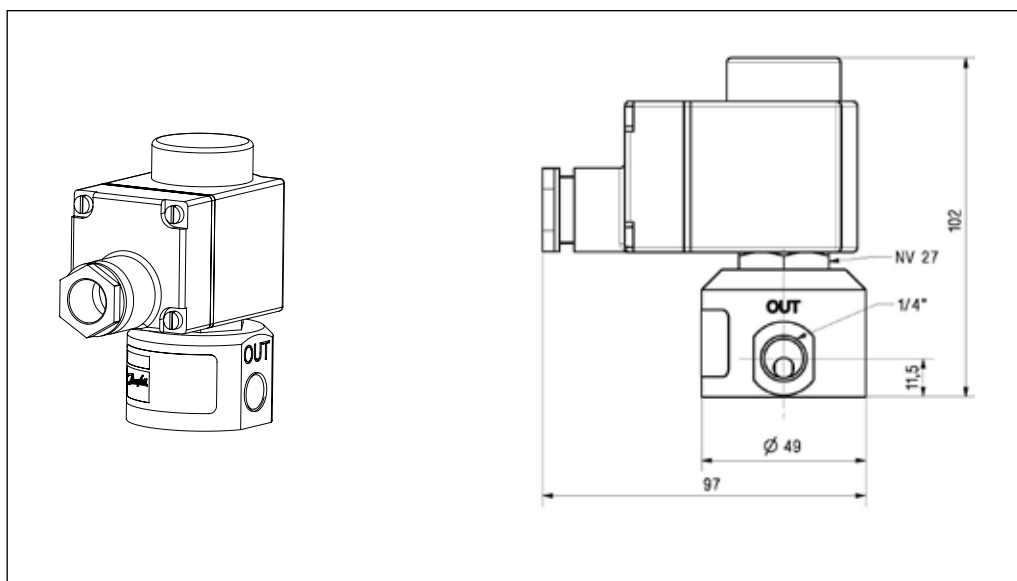

Spare parts VDH 2E 1/4 NC/NO 1.4 BSP

Armature kit NC 180L5002 / Pos.: 1, 5

Armature kit NO 180L5010 / Pos.: 4, 5

Orifice kit 4 180Z0097 / Pos.: 6, 7

Spare parts VDH 2E 1/4 NC 3.5 BSP

Armature kit NC 180L5002 / Pos.: 1, 5

Armature kit NO 180L5010 / Pos.: 4, 5

Orifice kit 5 180L4014 / Pos.: 6, 7

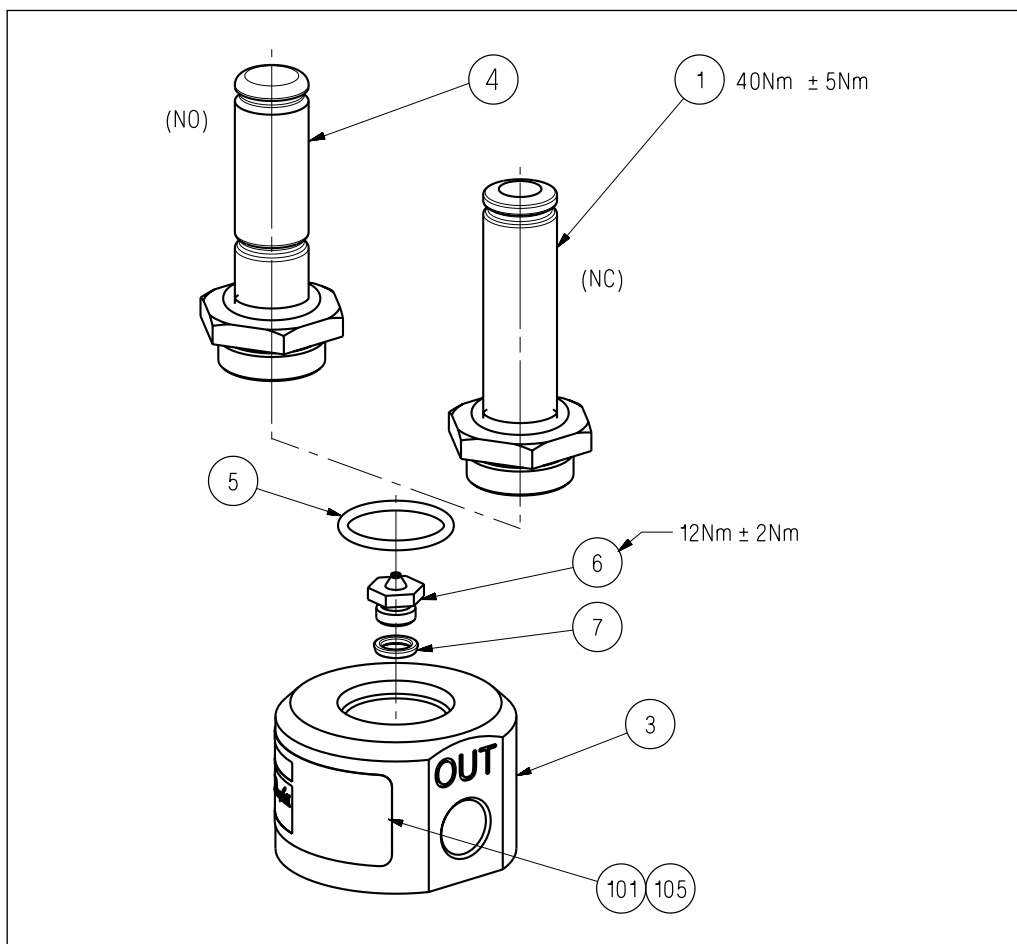

9. VDHT 1/4 E
Drawing
Spare parts

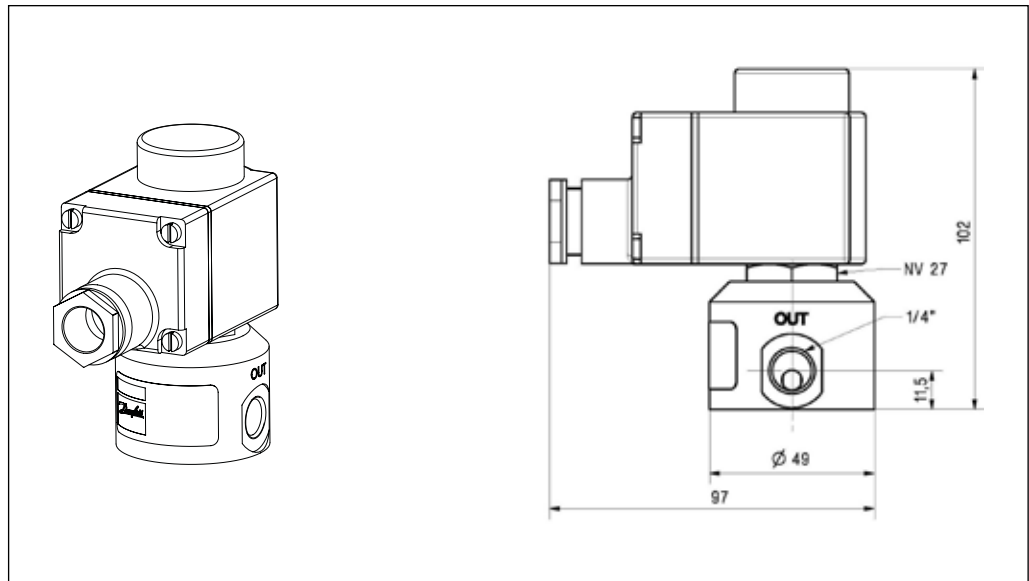

Spare parts

Armature kit NC	180L5002 / Pos.: 1, 5
Armature kit NO VDHT 1/4	180L5013 / Pos.: 4, 5
Piston kit $\phi 11.9$	180Z0251 / Pos.: 3

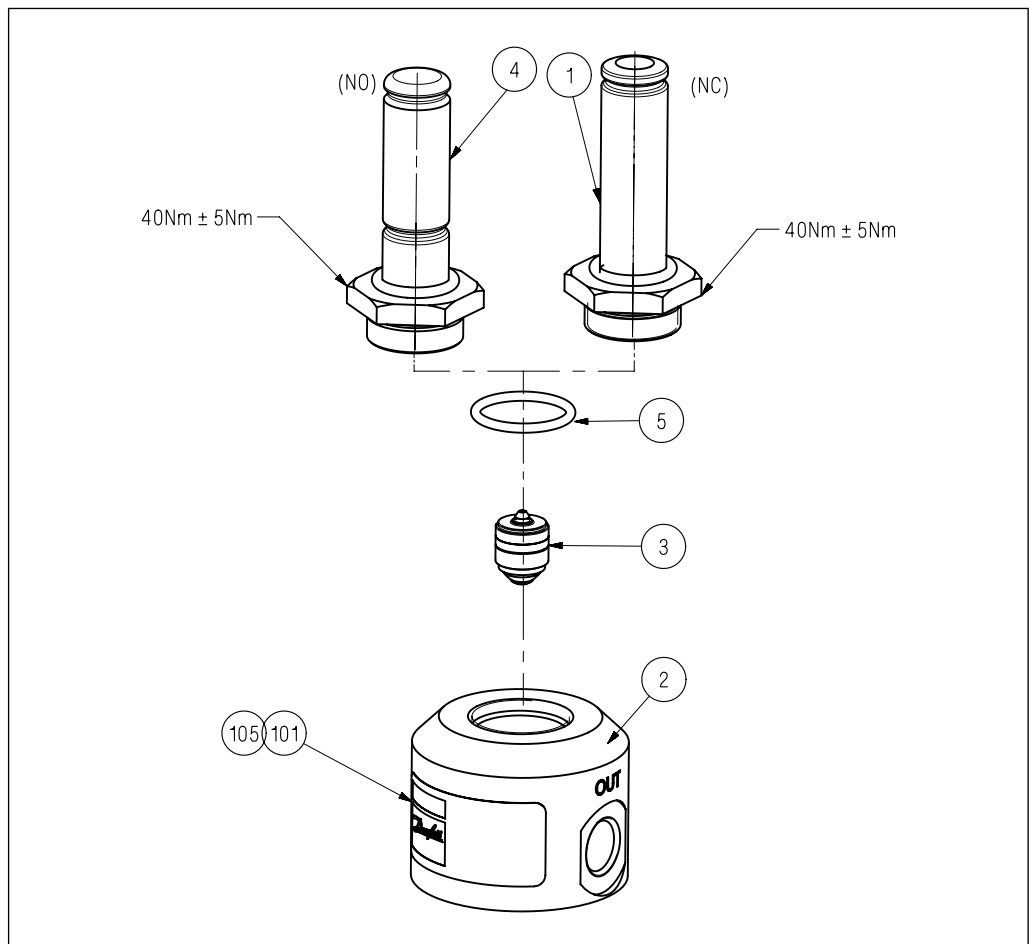

10. VDHT 3/8 E
VDHT 1/2 E
Drawing
Spare parts

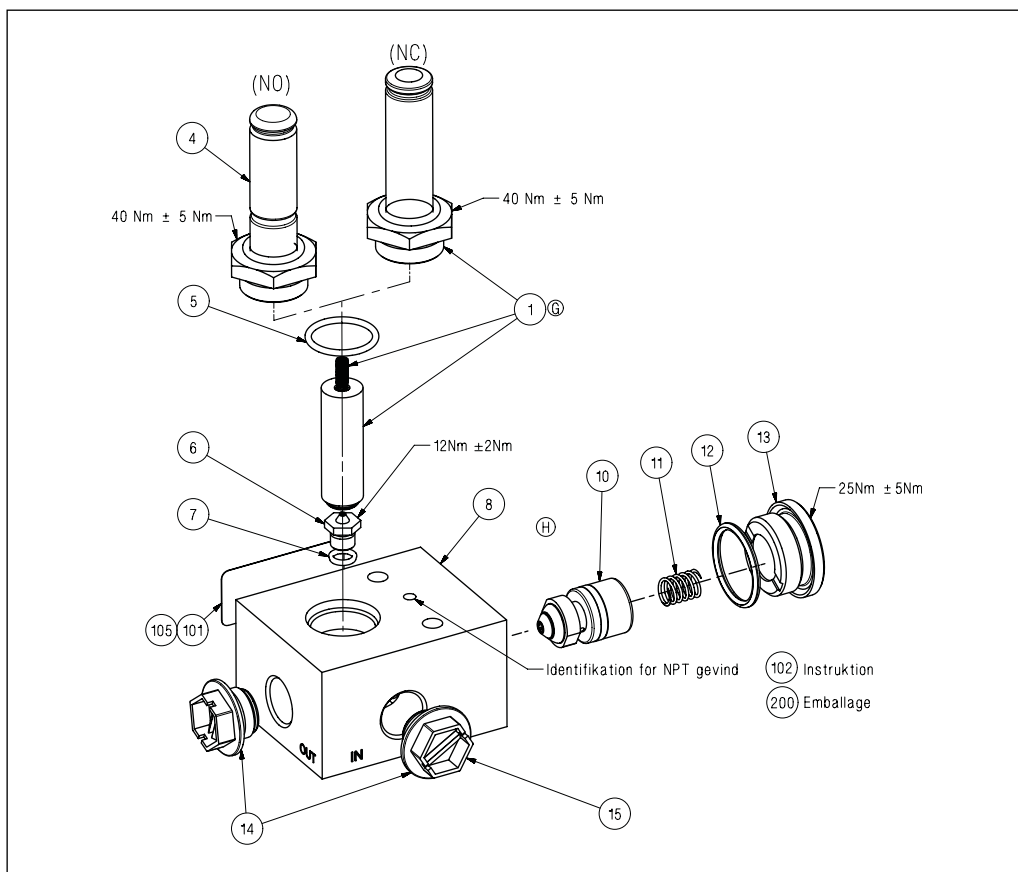
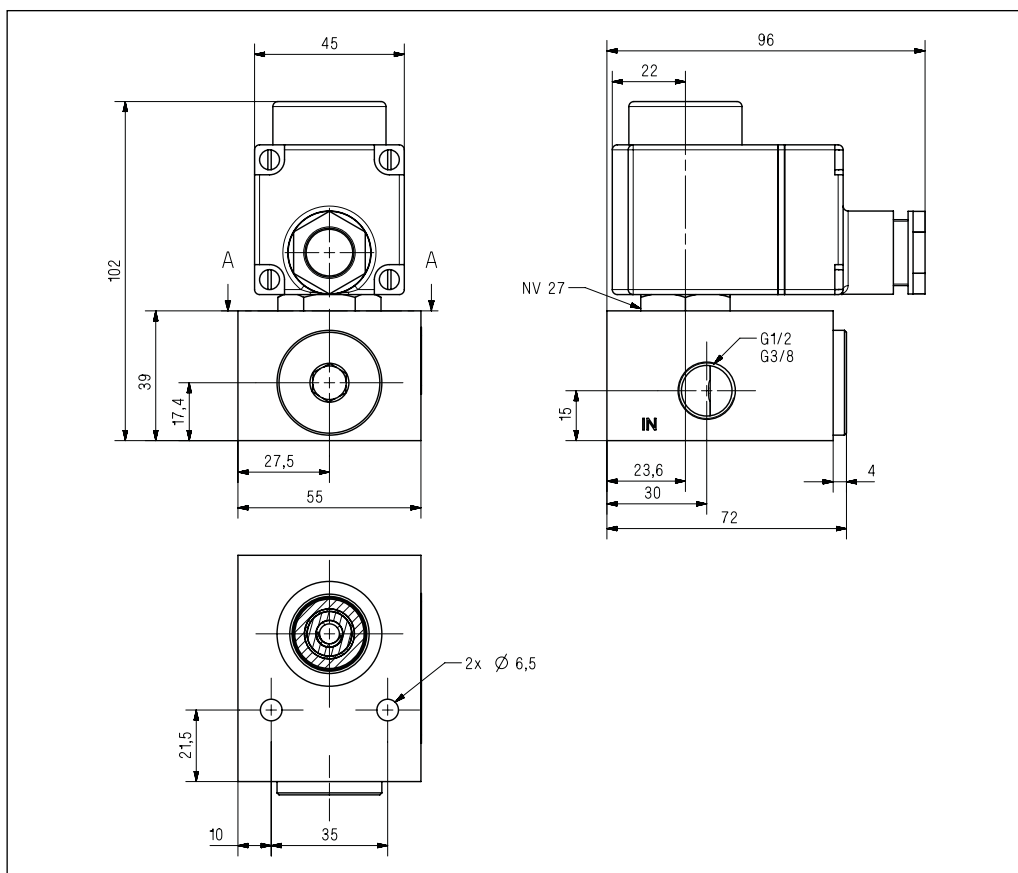

11. VDHT 3/8 EA
VDHT 1/2 EA
Drawing
Spare parts

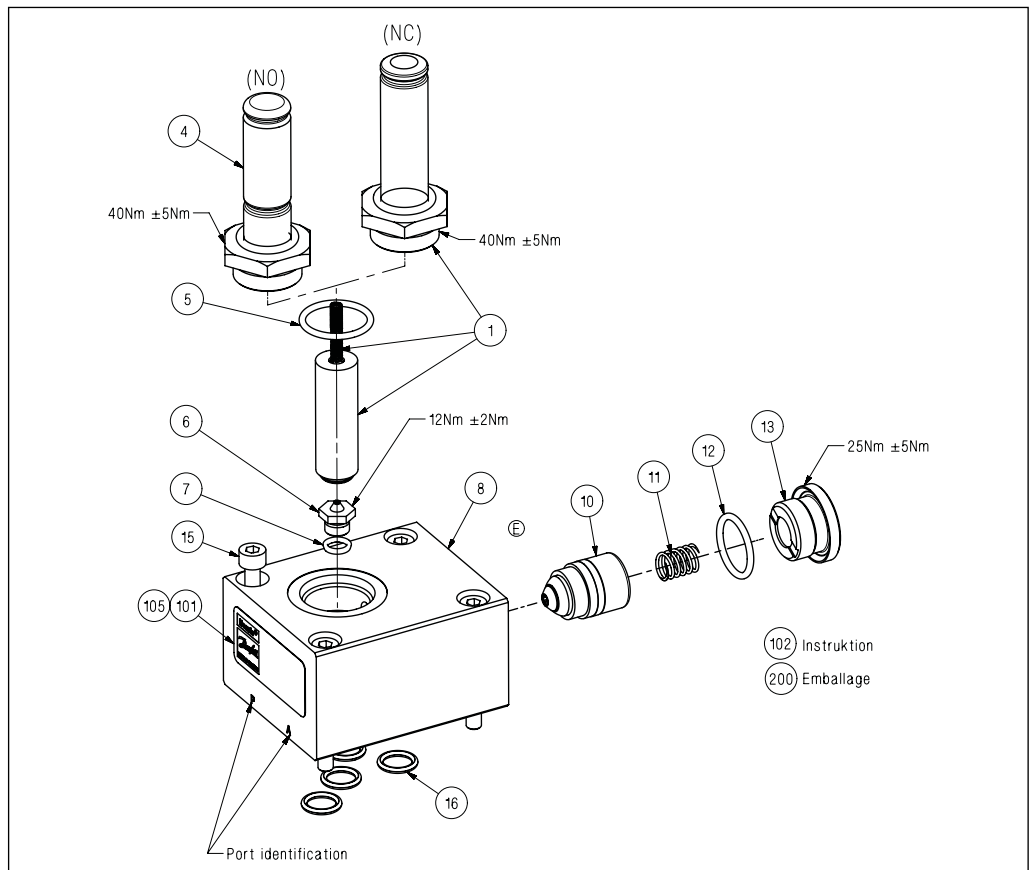
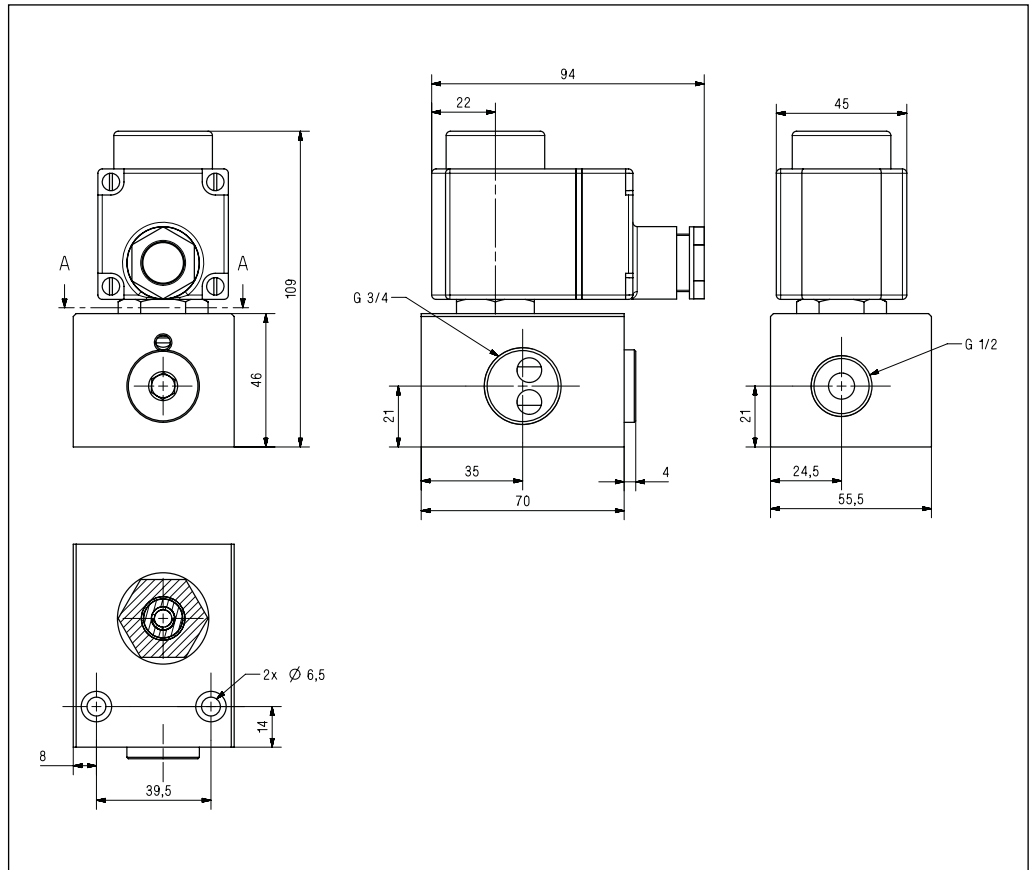

12. VDHT 3/4 ED N
VDHT 1 ED N
Drawing
Spare parts

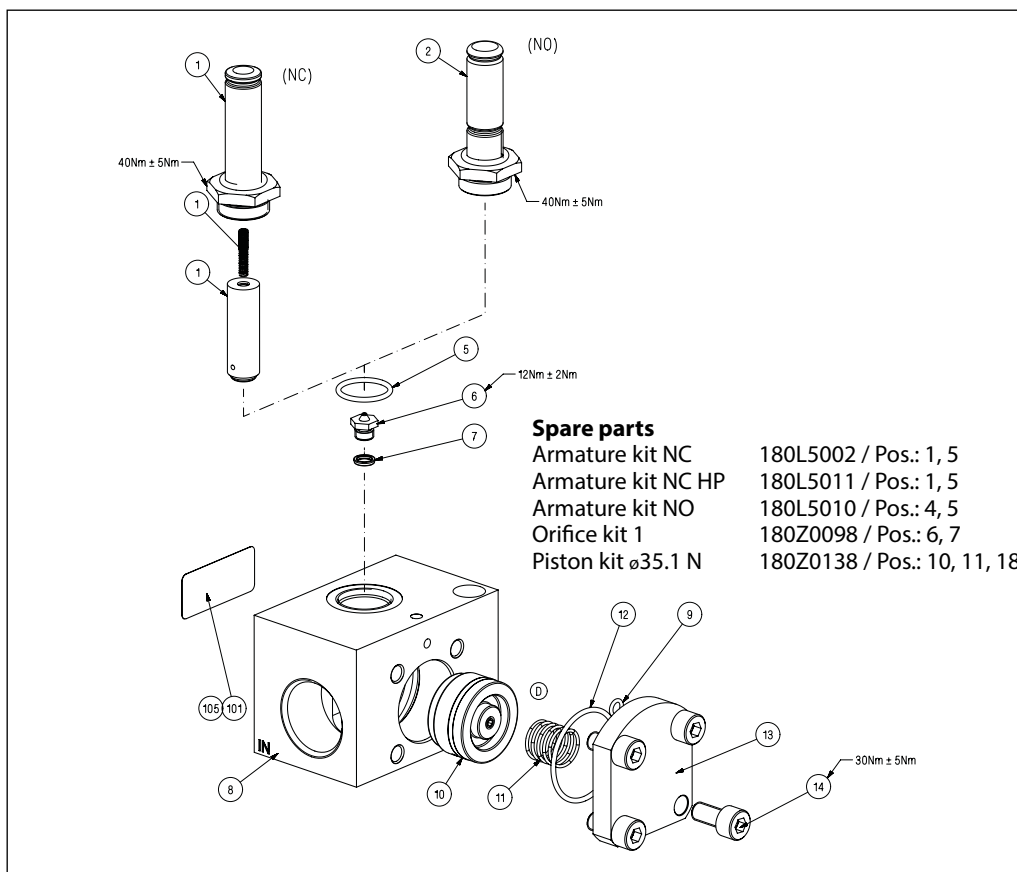
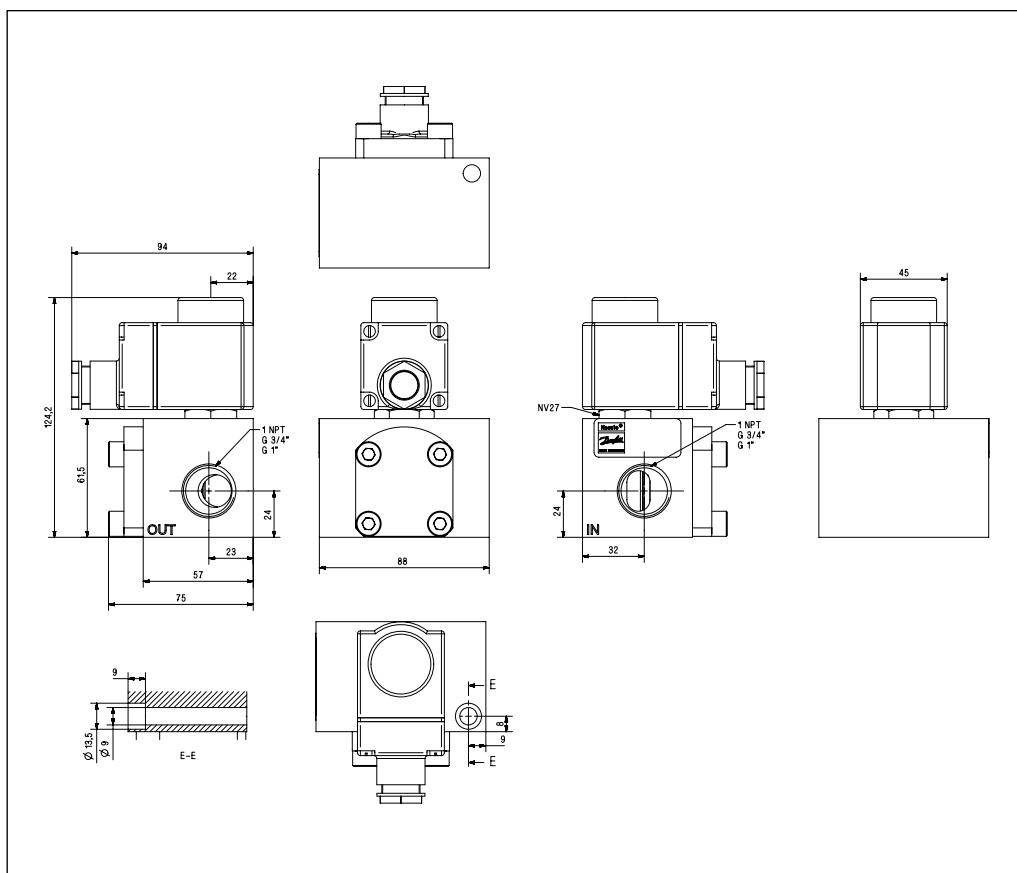

13. VDHT 3/4 EA
VDHT 1 EA
Drawing
Spare parts

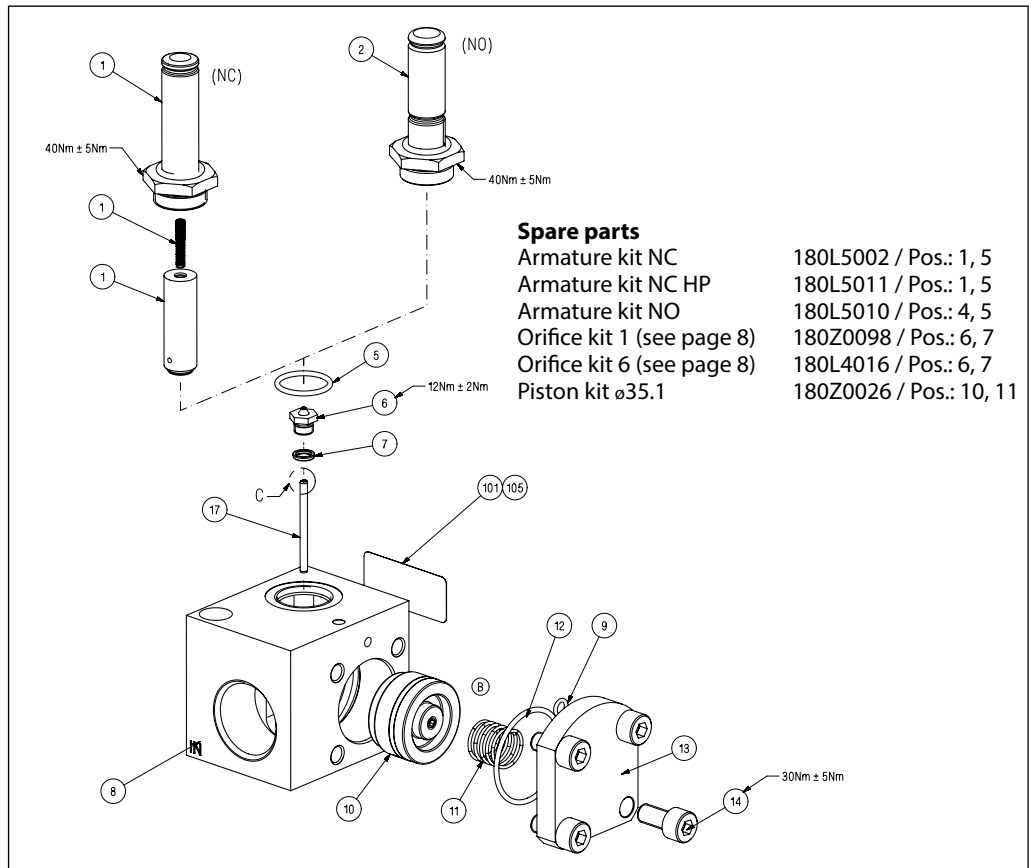
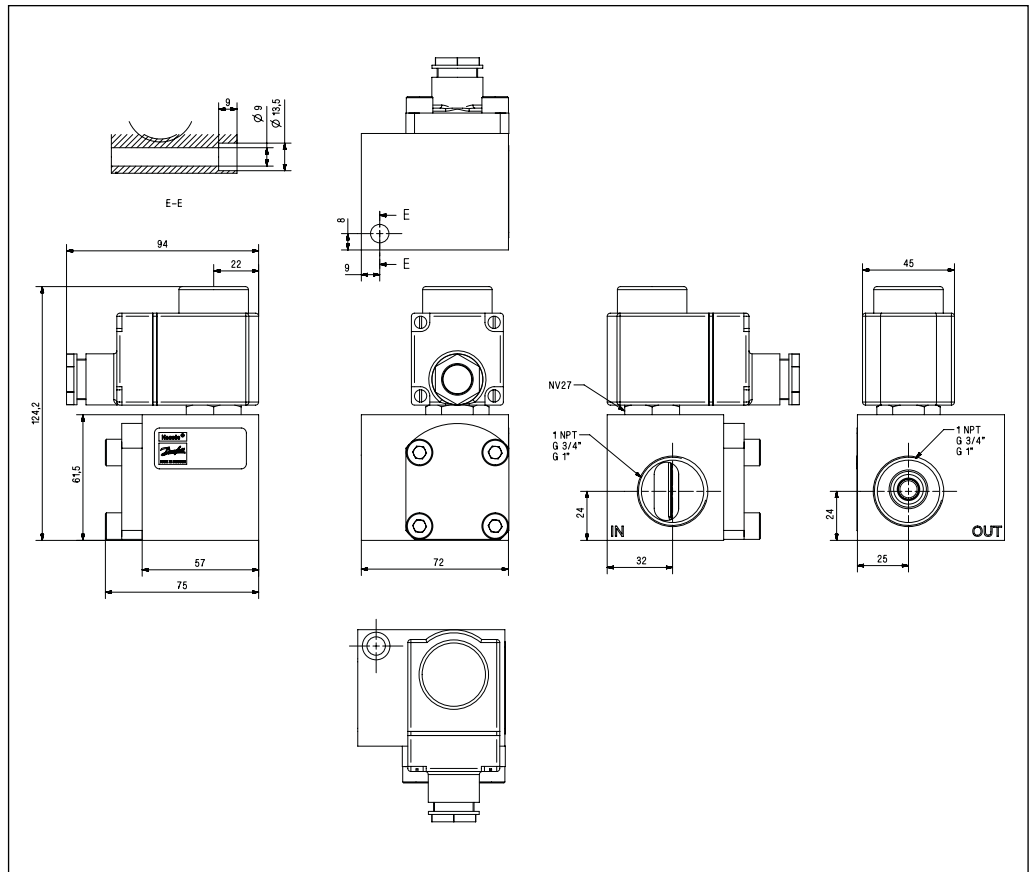

14. VDHT 3/4 EA N
VDHT 1 EA N
Drawing
Spare parts

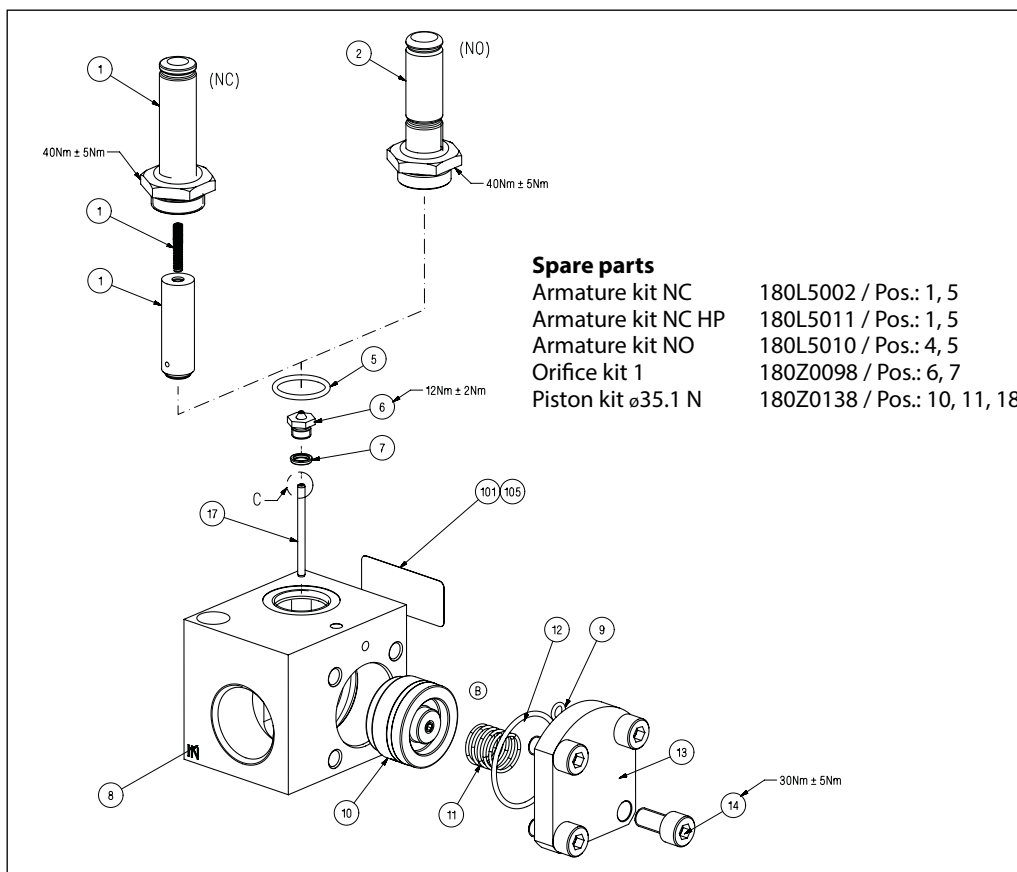
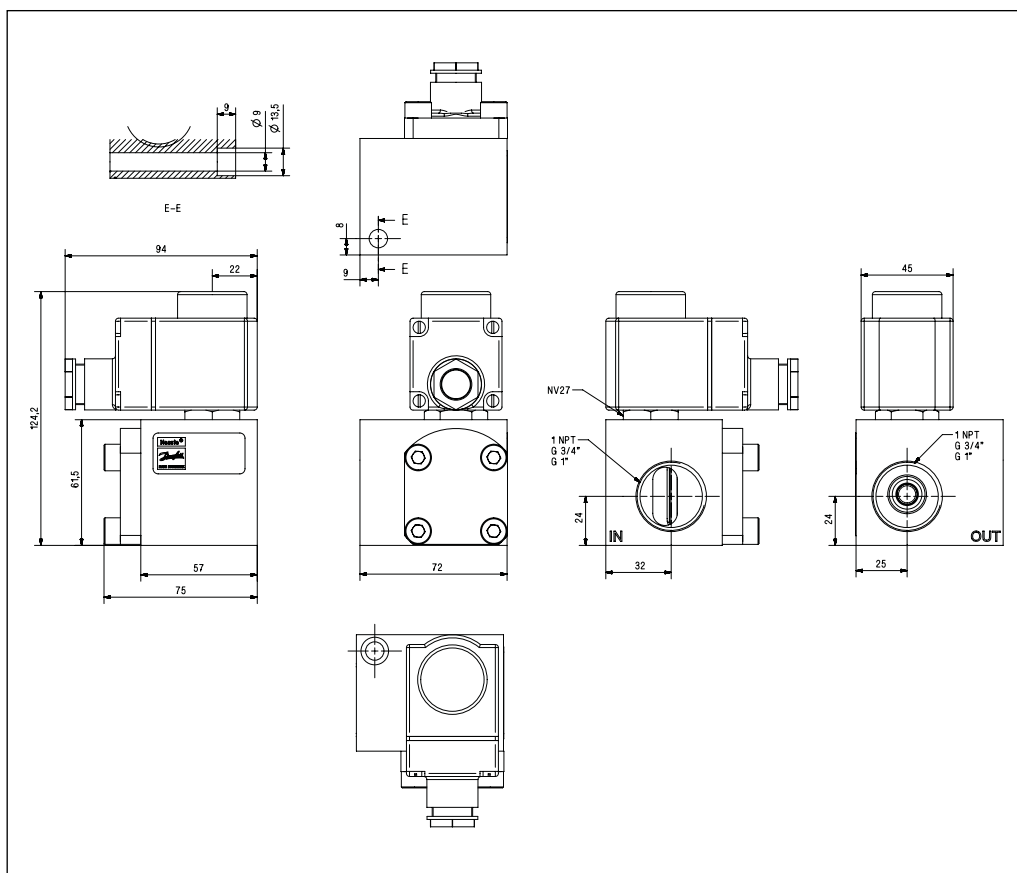

15. VDHT 30 EC
Drawing

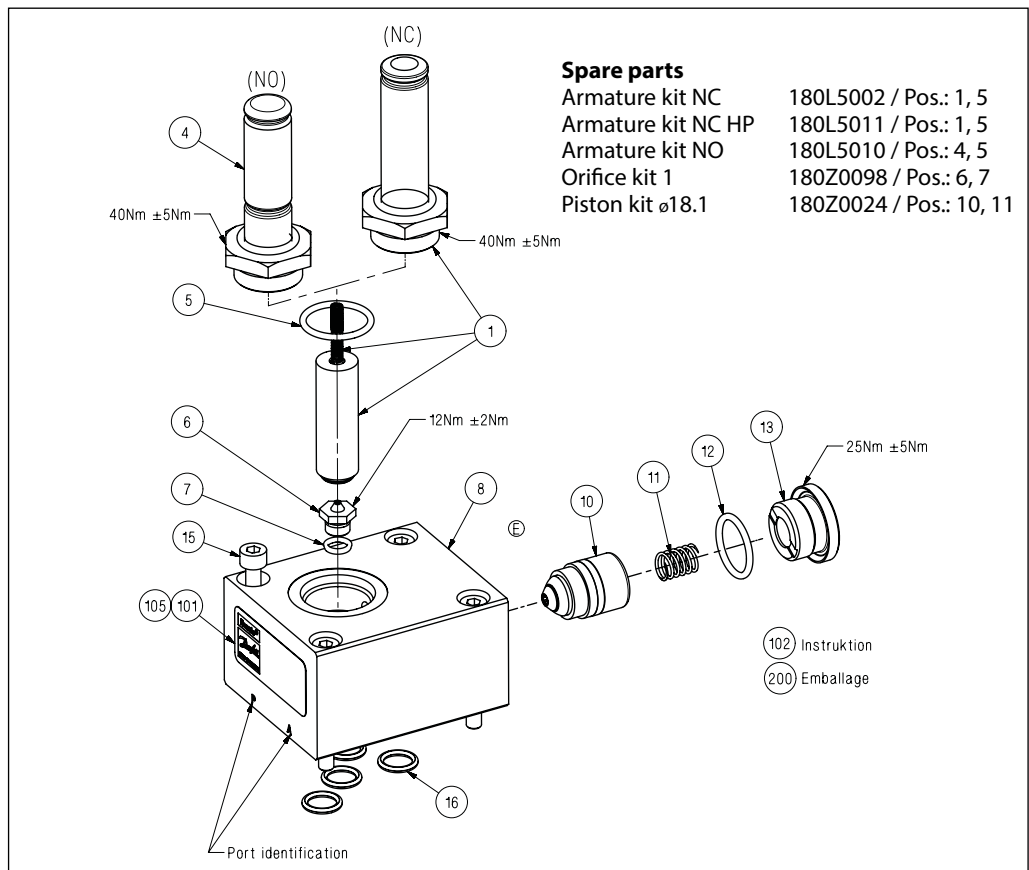
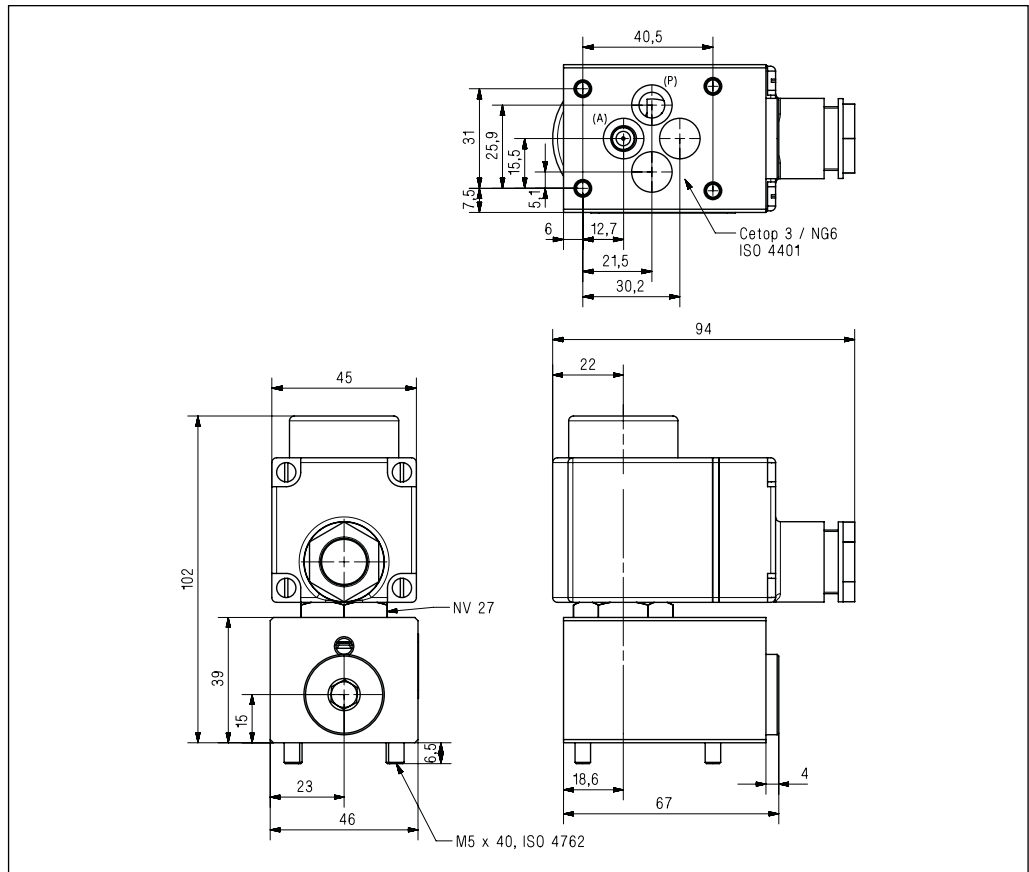

16. Block for CETOP 3 valves

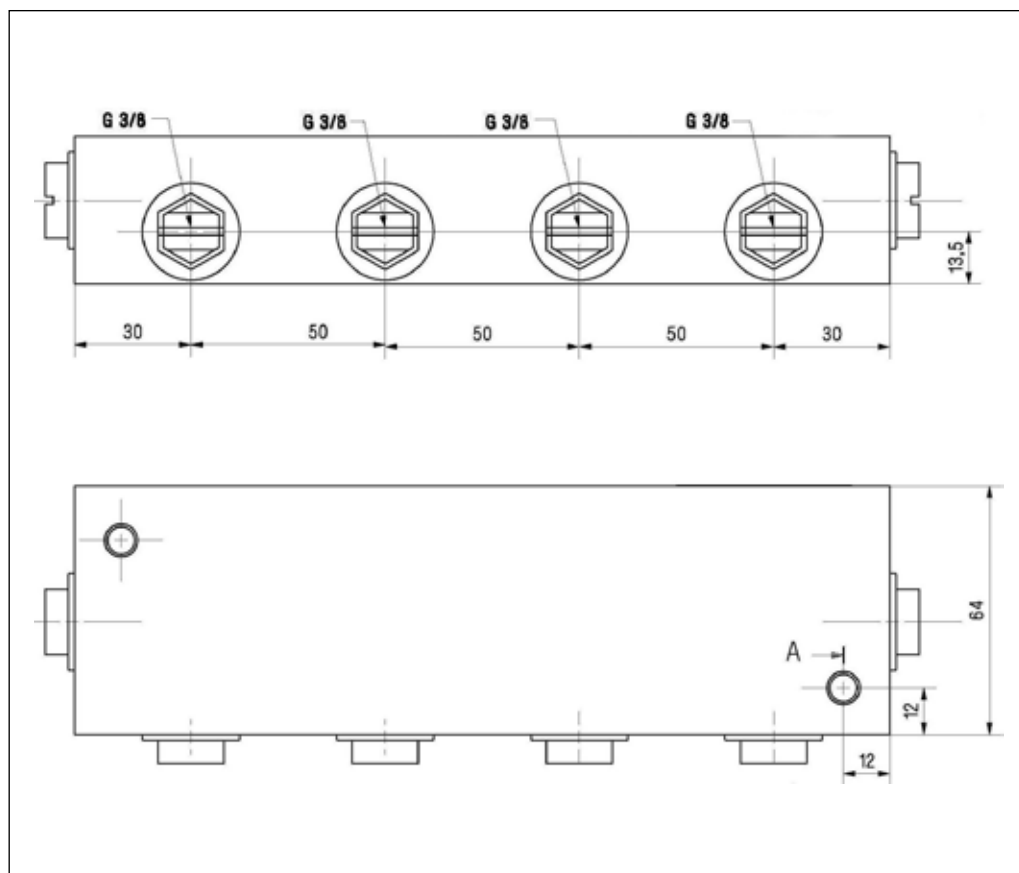

17. VDHT B
Spare parts

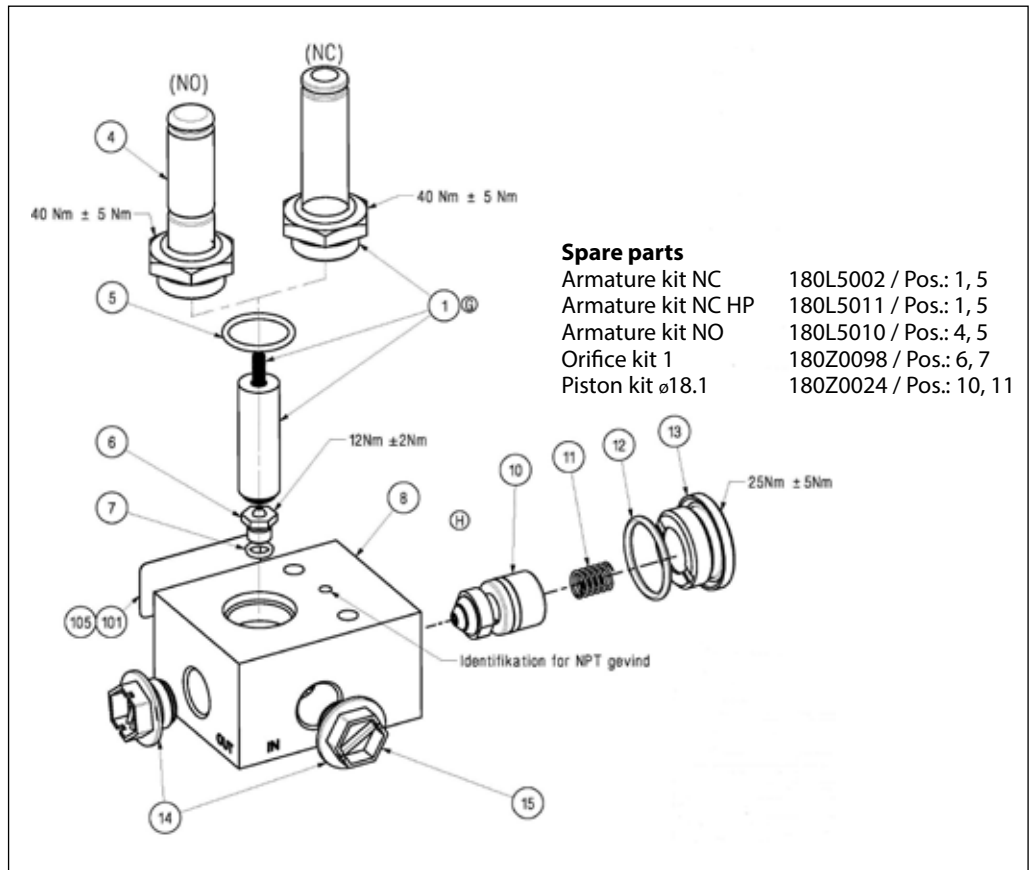
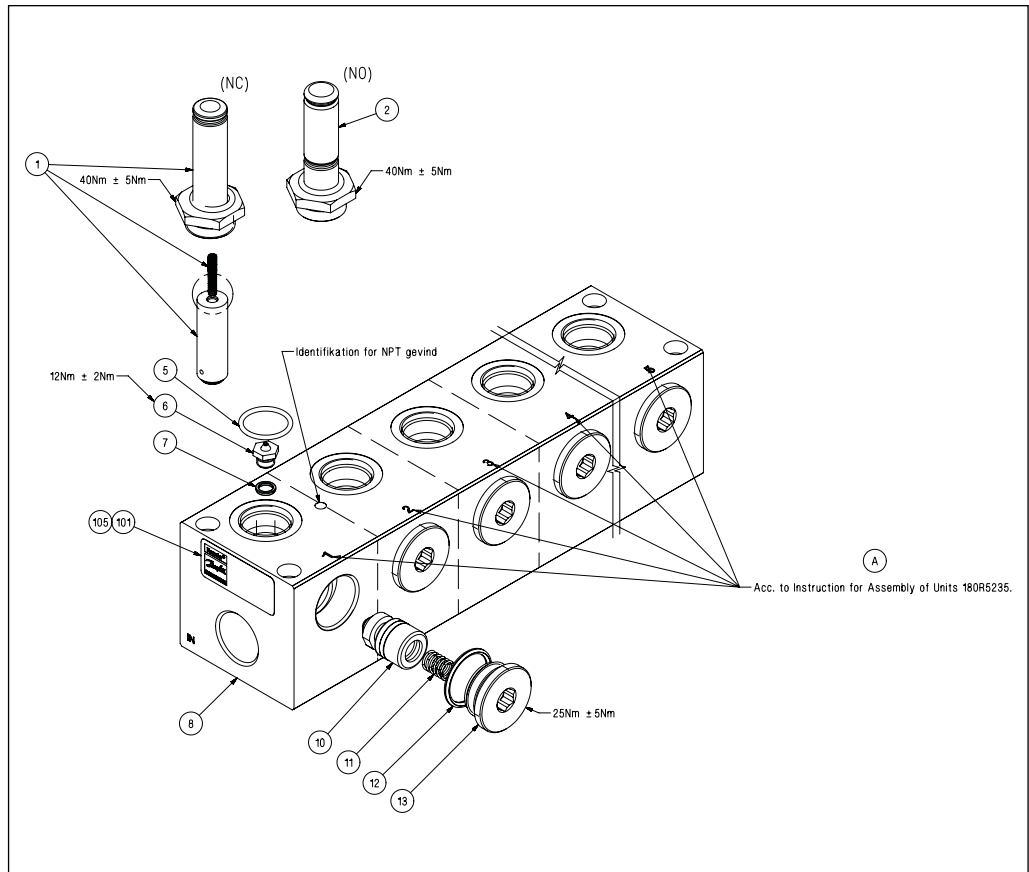

18. VDHT BL N Drawings

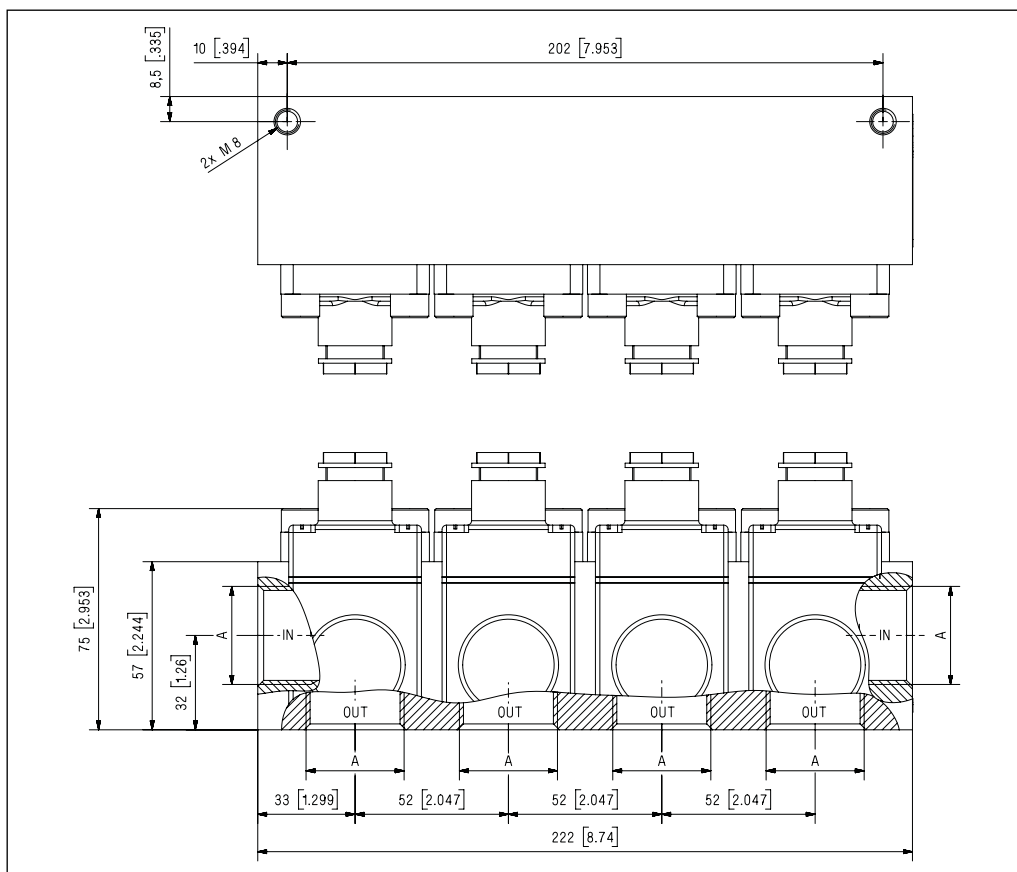
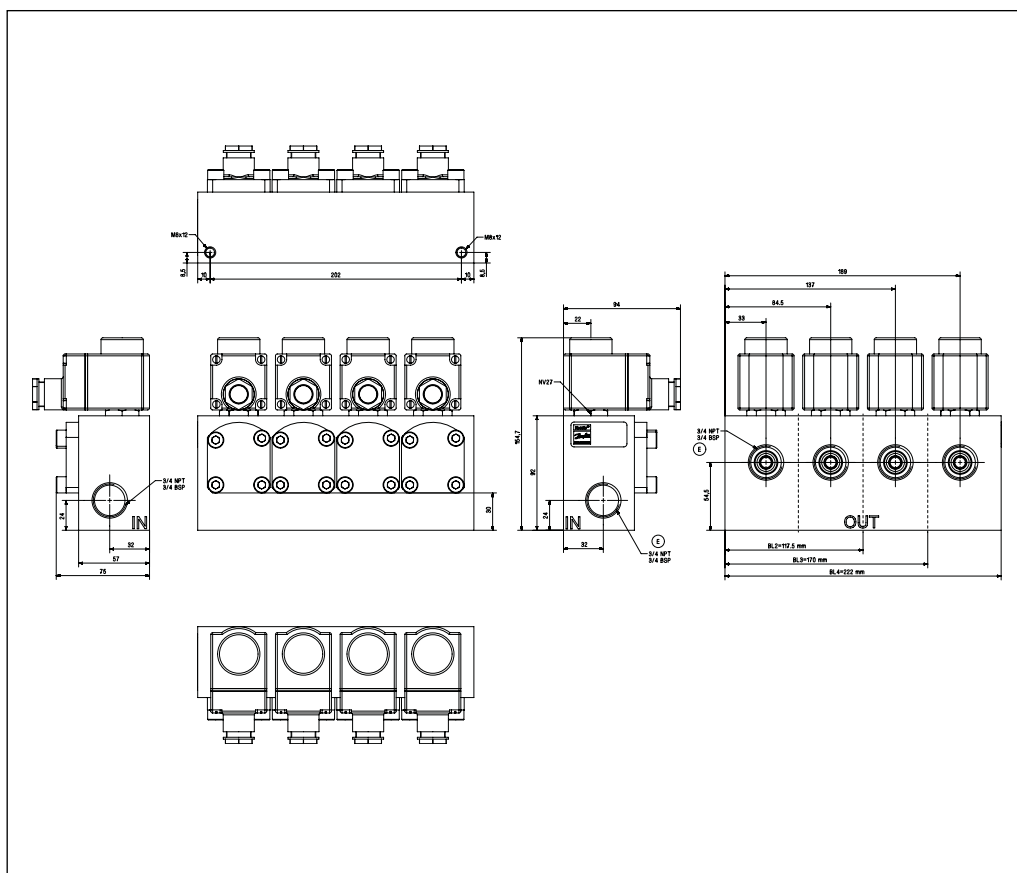

19. VDHT BL N
Spare parts

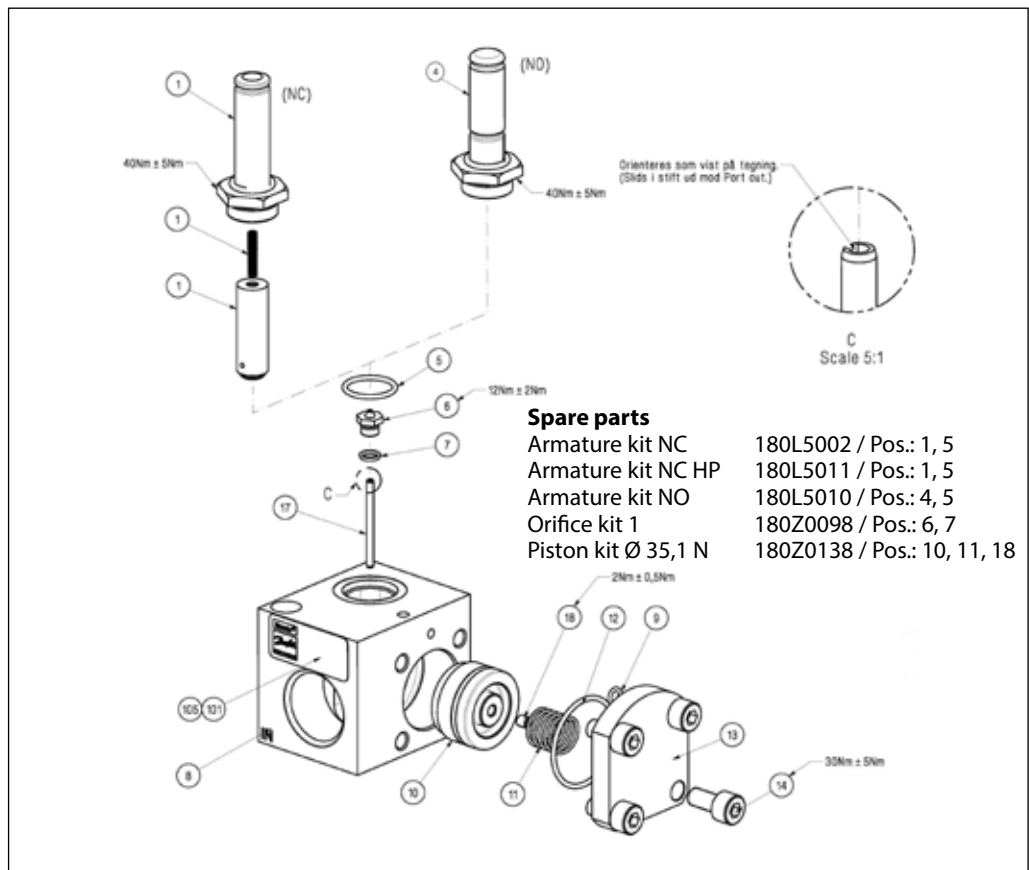
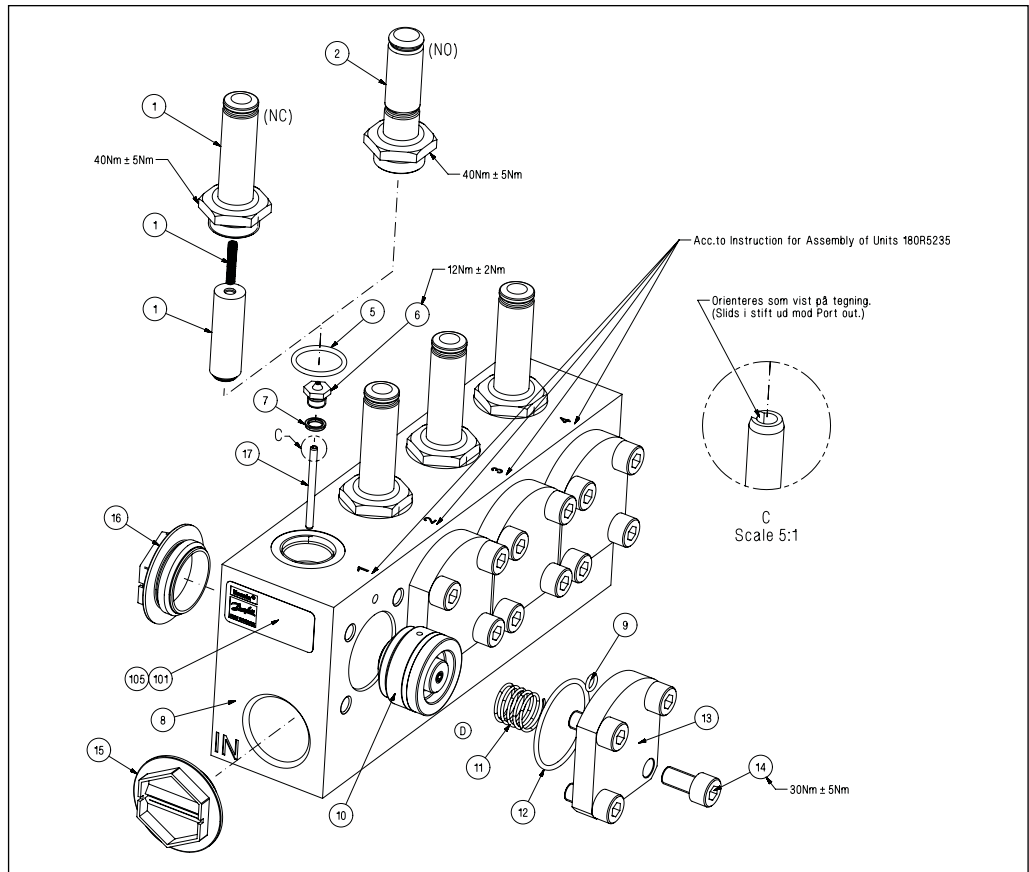

20. VDHT BLM Drawings

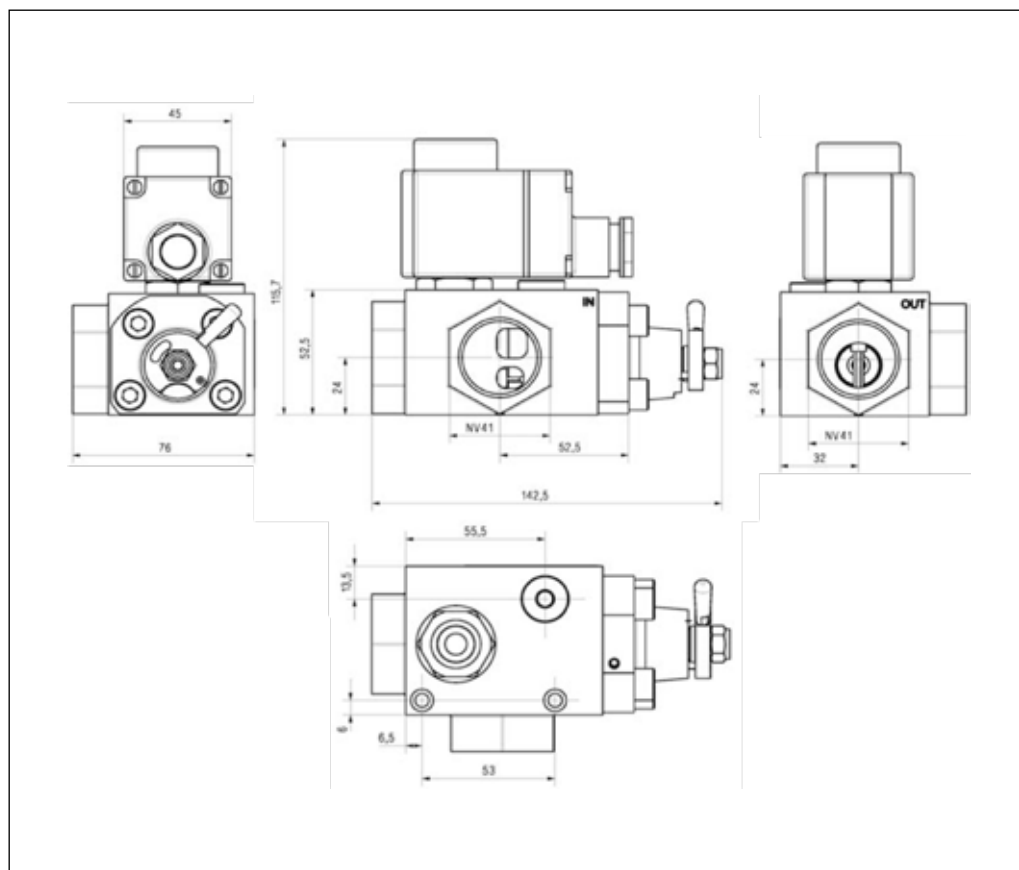
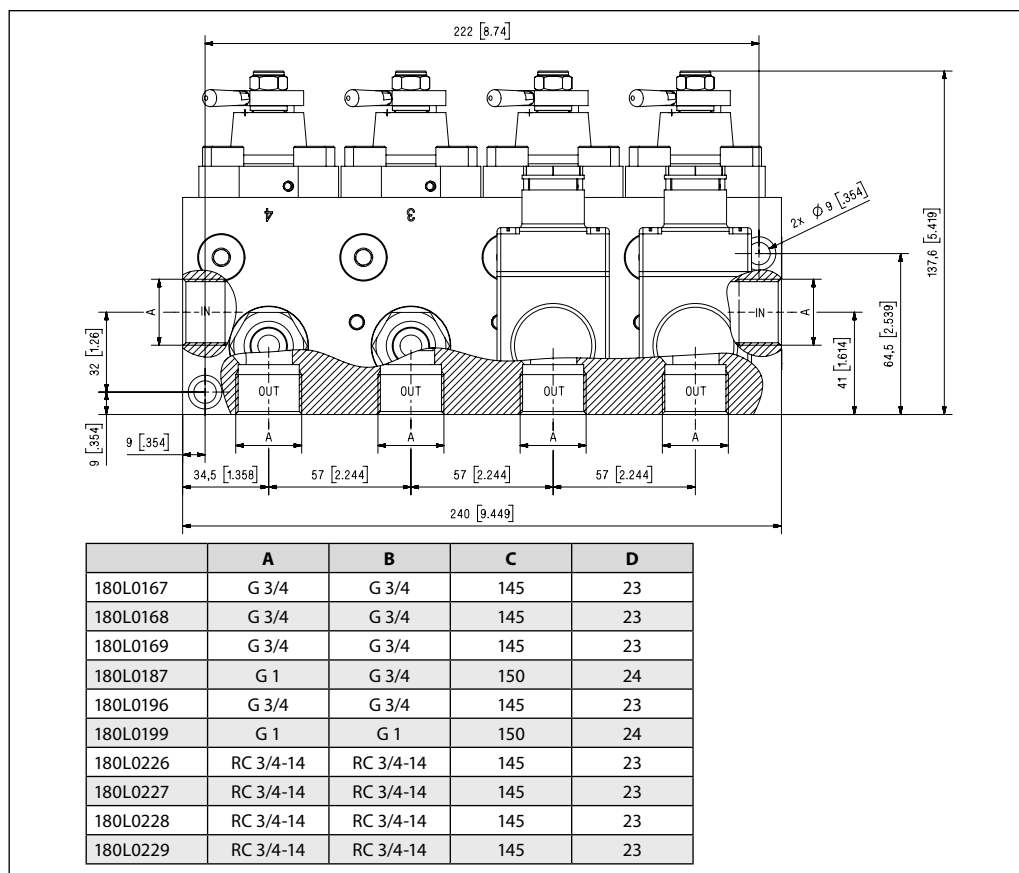

21. VDHT BLM
Spare parts

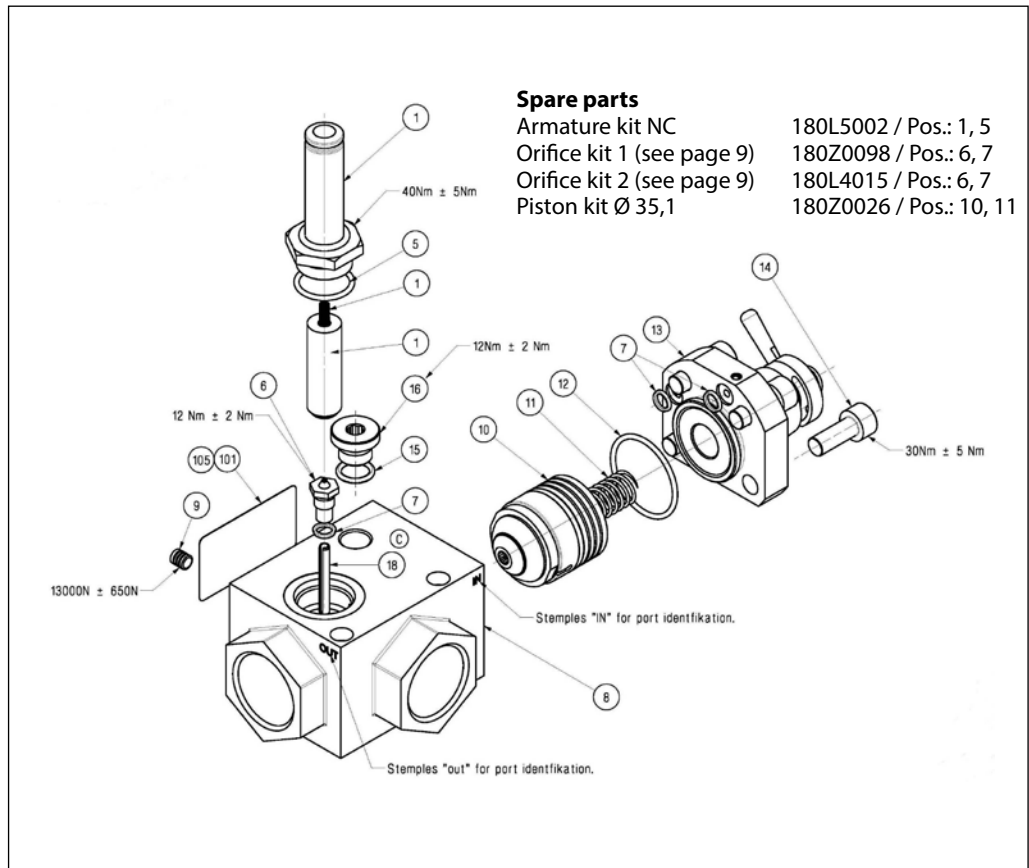
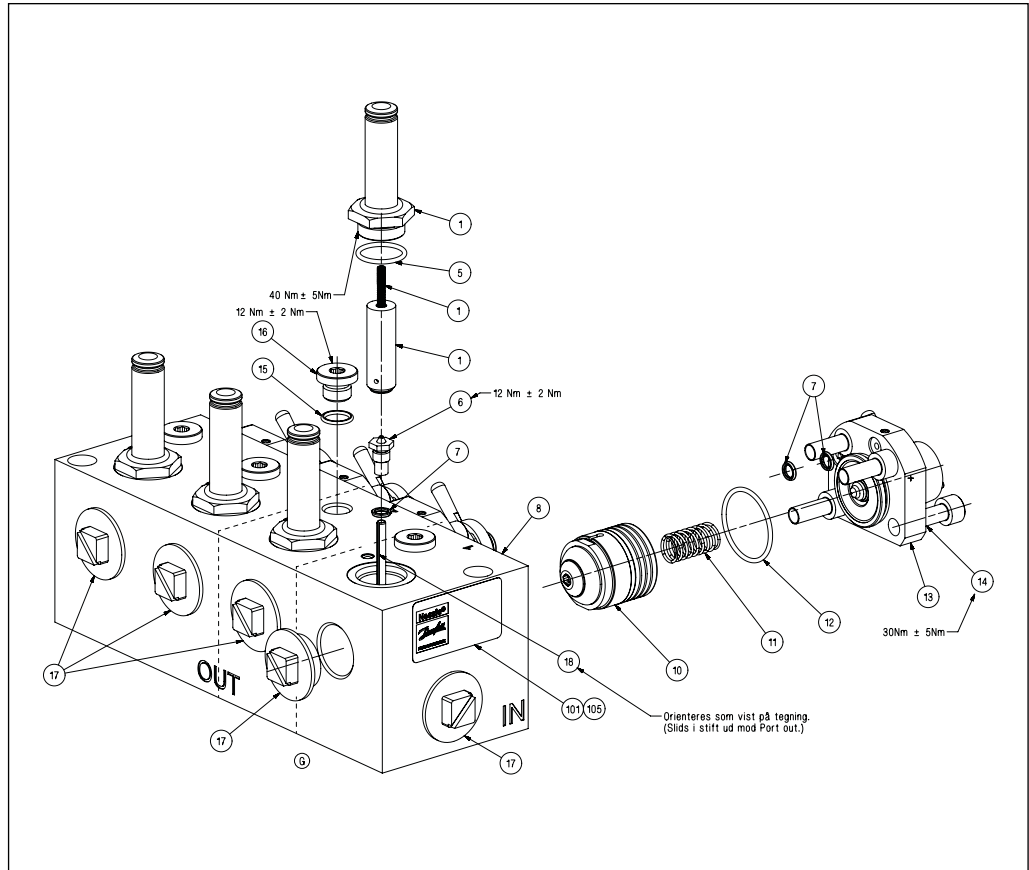

22. Overview spare parts

Valve type	Code no	Other	Pos. no. explosion drawing	T max °C (°F)	Weight kg (lbs)	Piston Ø mm	Orifice kit
------------	---------	-------	----------------------------	---------------	-----------------	-------------	-------------

Piston kit ø11.9 VDHT 1/4 E	180Z0251		3	90 (194)	0.09 (0.2)	ø11.9	-
--------------------------------	----------	--	---	----------	------------	-------	---



Piston kit ø18.1 VDHT 3/8 VDHT B	180Z0024		10, 11	90 (194)	0.09 (0.2)	ø18.1	-
--	----------	--	--------	----------	------------	-------	---



Piston kit ø35.1 VDHT 1 VDHT BL	180Z0026		10, 11	90 (194)	0.1 (0.4)	ø35.1	-
---------------------------------------	----------	--	--------	----------	-----------	-------	---



Piston kit ø35.1 N VDHT 3/4 to 1 N VDHT BL N	180Z0138	Slimline	10, 11	90 (194)	0.1 (0.4)	ø35.1 N	-
--	----------	----------	--------	----------	-----------	---------	---



Piston kit ø35.1 HP N VDHT 3/4 to 1 VDHT BL HP N	180Z0468	Slimline	10, 11	90 (194)	0.1 (0.4)	ø35.1 N	-
--	----------	----------	--------	----------	-----------	---------	---



Orifice kit 1 VDHT 1,0	180Z0098	standard	6, 7	90 (194)	0.09 (0.2)	-	1
------------------------	----------	----------	------	----------	------------	---	---



Orifice kit 2 VDHT 1,0	180L4015	BLM	6, 7	90 (194)	0.09 (0.2)	-	2
------------------------	----------	-----	------	----------	------------	---	---



Orifice kit 4 VDHT 2E 1.4	180Z0097	1.4	6, 7	90 (194)	0.09 (0.2)	-	4
---------------------------	----------	-----	------	----------	------------	---	---



Orifice kit 5 VDHT 2E 3,5	180L4014	3,5	6, 7	90 (194)	0.09 (0.2)	-	5
---------------------------	----------	-----	------	----------	------------	---	---



Orifice kit 6 VDHT 1,0	180L4016	formerly	6, 7	90 (194)	0.09 (0.2)	-	6
------------------------	----------	----------	------	----------	------------	---	---



Armature kit NC VDHT 1/4 to 1 VDHT B / BL / BL N	180L5002		1, 5	90 (194)	0.1 (0.4)	-	-
--	----------	--	------	----------	-----------	---	---



Armature kit NC HP VDHT 3/8 to 1 VDHT B / BL / BL N	180L5011		1, 5	90 (194)	0.1 (0.4)	-	-
---	----------	--	------	----------	-----------	---	---

Armature kit NO VDHT 3/8 to 1 VDHT B / BL / BL N	180L5010		4, 5	90 (194)	0.1 (0.4)	-	-
--	----------	--	------	----------	-----------	---	---

Armature kit NO HP VDHT 1/4 VDHT B / BL / BL N	180L5013		4, 5	90 (194)	0.1 (0.4)	-	-
--	----------	--	------	----------	-----------	---	---

23. Pressure losses p
INLET to OUTLET

VDH 2 E 1/4 1.4
VDH 2 E 1/4 3.5

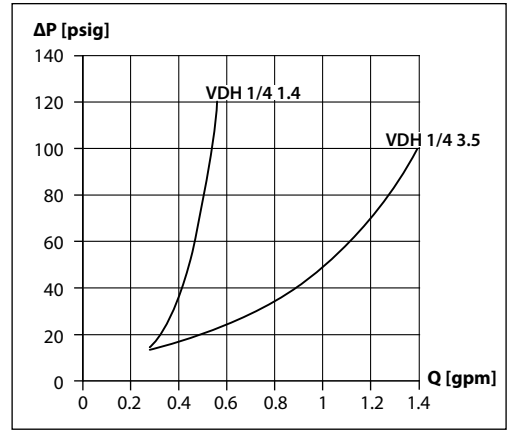
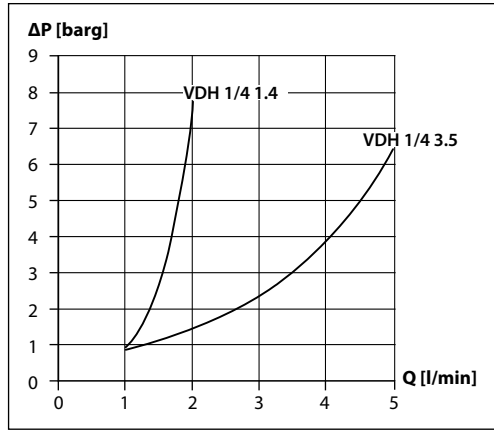

VDHT 1/4 E

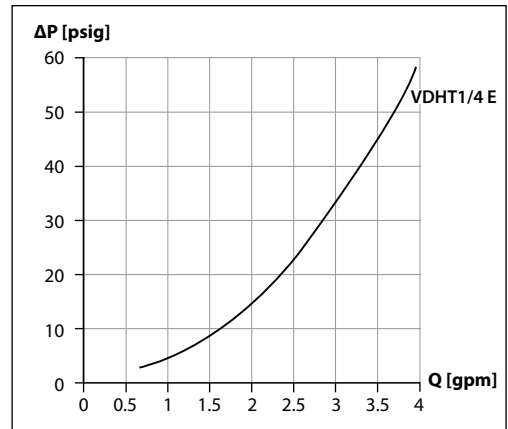
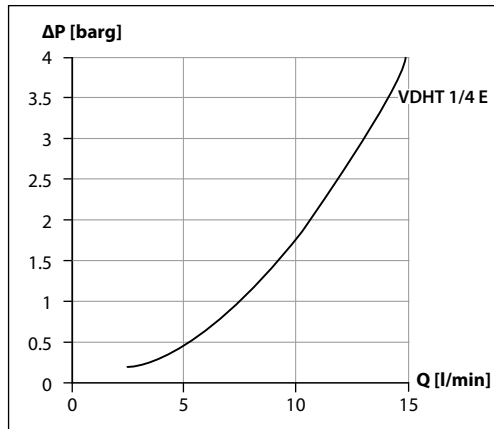

VDHT 3/8 E
VDHT 3/8 EA

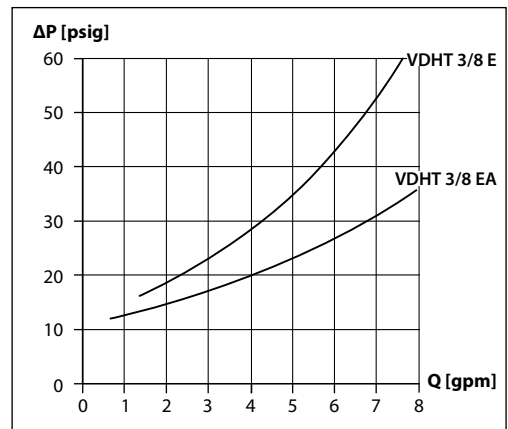
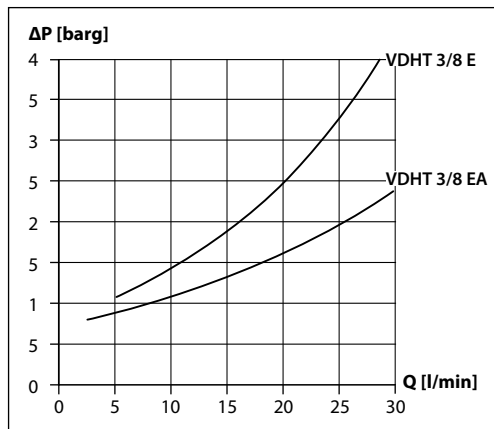

**VDHT 1/2 E
VDHT 1/2 EA**

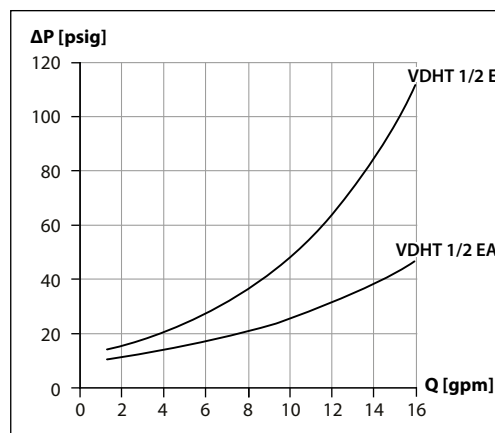
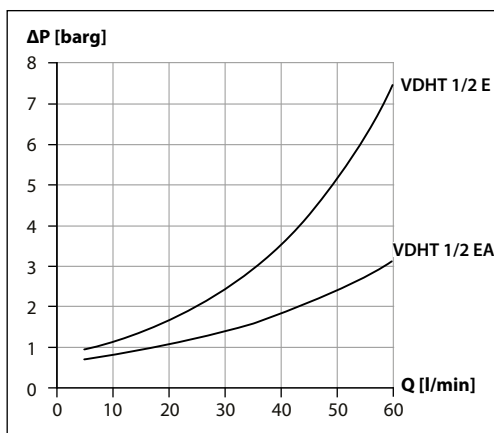

**VDHT 3/4 ED
VDHT 3/4 EA**

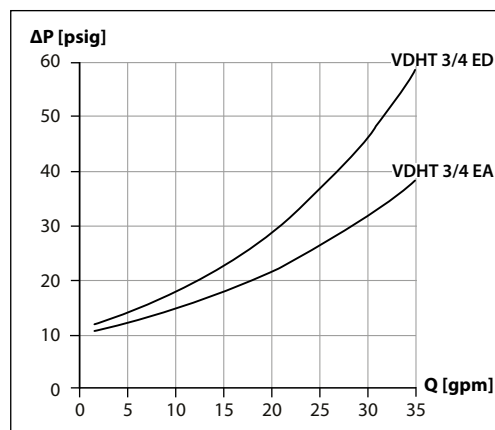
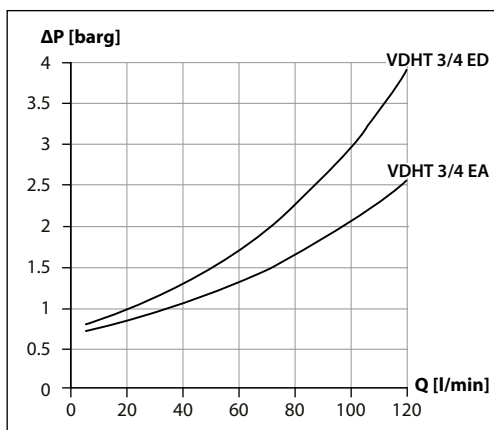

**VDHT 1 ED
VDHT 1 EA**

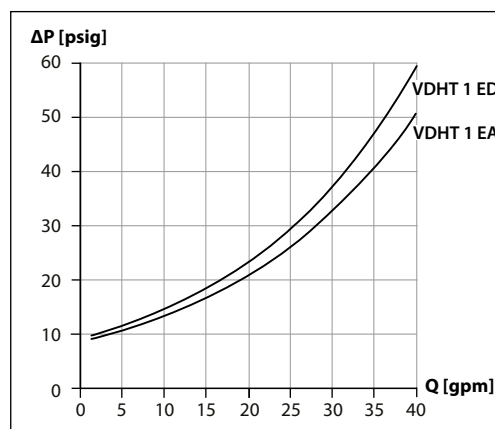
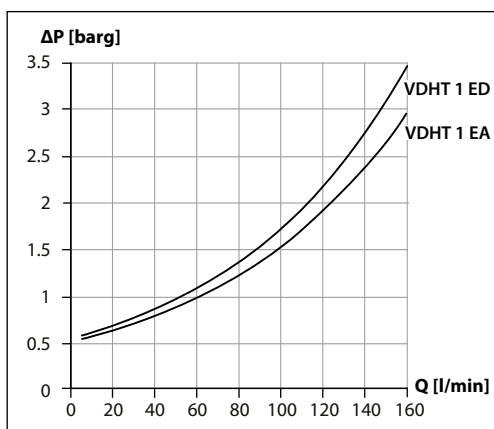

VDHT 30 EC

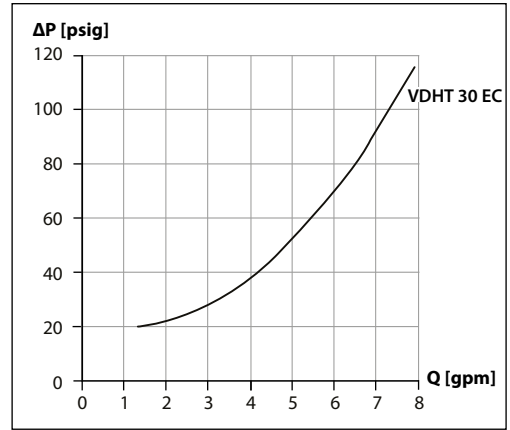
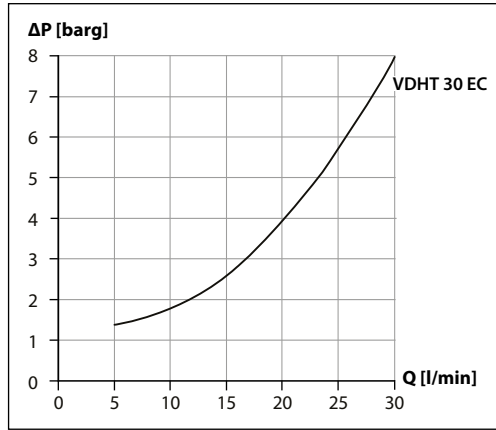

**VDHT 3/4 EAM
VDHT 1 EAM**

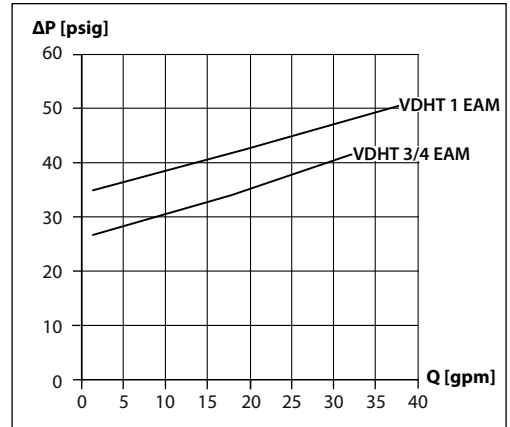
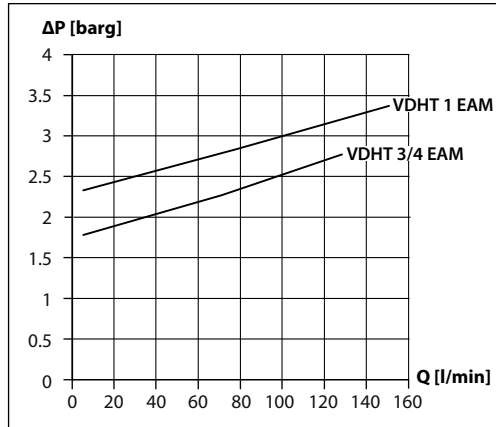

**VDHT 3/4 BL
VDHT 1**

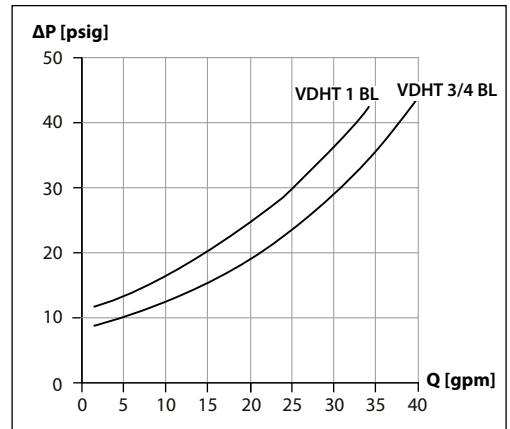
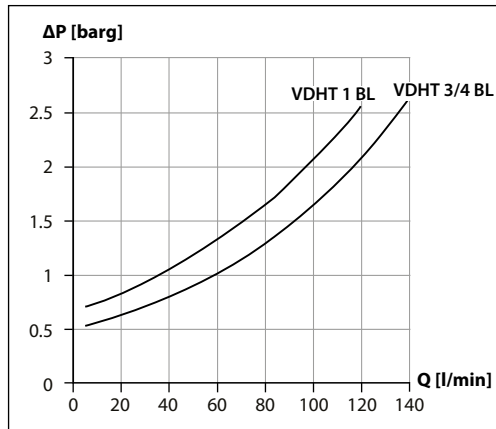

Danfoss A/S
High Pressure Pumps
DK-6430 Nordborg
Denmark

Danfoss can accept no responsibility for possible errors in catalogues, brochures and other printed material. Danfoss reserves the right to alter its products without notice. This also applies to products already on order provided that such alterations can be made without subsequential changes being necessary in specifications already agreed. All trademarks in this material are property of the respective companies. Danfoss and the Danfoss logotype are trademarks of Danfoss A/S. All rights reserved.
